



# **PHASE 5 OPL USER'S MANUAL**

---

**American Dryer Corporation**  
88 Currant Road  
Fall River, MA 02720-4781  
Telephone: (508) 678-9000 / Fax: (508) 678-9447  
E-mail: [techsupport@amdry.com](mailto:techsupport@amdry.com)  
[www.amdry.com](http://www.amdry.com)

# **Retain This Manual In A Safe Place For Future Reference**

Please read this manual carefully to thoroughly familiarize yourself with the Phase 5 OPL computer system features, operational instructions, and programming characteristics. This manual contains important information on how to employ all the features of your new **ADC** dryer in the safest and most economical way.

**American Dryer Corporation** products embody advanced concepts in engineering, design, and safety. If this product is properly maintained, it will provide many years of safe, efficient, and trouble-free operation.

We have tried to make this manual as complete as possible and hope you will find it useful. **ADC** reserves the right to make changes from time to time, without notice or obligation, in prices, specifications, colors, and material, and to change or discontinue models at any time.

Replacement parts can be ordered from your distributor or the **ADC** factory. When ordering replacement parts from the factory, you can FAX your order to **ADC** at (508) 678-9447 or telephone your orders directly to the **ADC** Parts Department at (508) 678-9000. Please specify the dryer model number and serial number in addition to the description, and part number, so that your order is processed accurately and promptly.

## **“IMPORTANT NOTE TO PURCHASER”**

Information must be obtained from your local gas supplier on the instructions to be followed if the user smells gas. These instructions must be posted in a prominent location near the dryer.

## **IMPORTANT**

**YOU MUST DISCONNECT and LOCKOUT THE ELECTRIC SUPPLY and THE GAS SUPPLY or THE STEAM SUPPLY BEFORE ANY COVERS or GUARDS ARE REMOVED FROM THE MACHINE TO ALLOW ACCESS FOR CLEANING, ADJUSTING, INSTALLATION, or TESTING OF ANY EQUIPMENT per OSHA (Occupational Safety and Health Administration) STANDARDS.**

## **FOR YOUR SAFETY**

**DO NOT STORE OR USE GASOLINE OR OTHER FLAMMABLE VAPOR AND LIQUIDS IN THE VICINITY OF THIS OR ANY OTHER APPLIANCE.**

**DO NOT DRY MOP HEADS IN THE DRYER.**

**DO NOT USE DRYER IN THE PRESENCE OF DRY CLEANING FUMES.**

## **CAUTION**

**DRYER(S) SHOULD NEVER BE LEFT UNATTENDED WHILE IN OPERATION.**

## **WARNING**

**CHILDREN SHOULD NOT BE ALLOWED TO PLAY ON OR NEAR THE DRYER(S).**

**CHILDREN SHOULD BE SUPERVISED IF NEAR DRYER(S) IN OPERATION.**

## **WARNING**

**The dryer must never be operated with any of the back guards, outer tops, or service panels removed. PERSONAL INJURY or FIRE COULD RESULT.**

## **WARNING**

**DRYER MUST NEVER BE OPERATED WITHOUT THE LINT FILTER/SCREEN IN PLACE...EVEN IF AN EXTERNAL LINT COLLECTION SYSTEM IS USED.**

## **IMPORTANT**

**PLEASE OBSERVE ALL SAFETY PRECAUTIONS displayed on the equipment and/or specified in the installation/operator's manual included with the dryer.**

Dryer(s) **must not** be installed or stored in an area where it will be exposed to water and/or weather.

The wiring diagram for the dryer is located in the front electrical control box area.

# Table of Contents

## SECTION I

<b>INTRODUCTION .....</b>	<b>4</b>
Phase 5 “On-Premise Laundry” (OPL) Microprocessor Drying System .....	4

## SECTION II

<b>FEATURES .....</b>	<b>5</b>
-----------------------	----------

## SECTION III

<b>PROGRAM SELECTIONS .....</b>	<b>7</b>
A. Preprogrammed Cycles .....	7
B. Manually Loaded Cycles .....	8
C. Automatic Drying Cycle/Mode ( <b>Patent No. 4,827,627</b> ) .....	9
D. Timed (Manual) Drying Cycle (Mode) .....	10
E. Temperature Selections (Drying Temperatures) .....	10
F. Cool Down Cycle .....	10
G. L.E.D. (Light Emitting Diode) Display .....	11
H. Cycle In Progress Temperature Display .....	12
I. Temperature Conversion Status .....	12
J. Anti-Wrinkle Program .....	12
K. Audible Tone Signal .....	13
L. Preprogrammed Cycle Preview .....	13
M. Reversing Option .....	13
N. Diagnostics .....	14
O. System Parameters (Program Locations/Review) .....	14
1. Program Location 2 ( <b>Key “2”</b> ) .....	
a. Temperature Conversion Status .....	15
b. Select Reverse .....	15
c. Rotation Sensor Selection .....	15
d. Factor “A” (Slope Program) .....	15
e. Factor “B” (Heat Loss [Offset] Program) .....	16
2. Program Location 5 ( <b>Key “5”</b> ) .....	
a. Flash Display Status .....	16
b. Flash Cycle Display Time .....	16
c. Flash Temperature Display Time .....	16
3. Program Location 8 ( <b>Key “8”</b> ) .....	
a. Cool Down Time .....	16
b. Cool Down Temperature .....	16
c. Spin Time .....	16
d. Dwell (Stop) Time .....	17
e. Buz (Tone) Time .....	17

4. Program Location 0 (Key “0”)	
a. Anti-Wrinkle Program Activation .....	17
b. Buz Time (Anti-Wrinkle Tone) .....	17
c. Anti-Wrinkle On Time .....	17
d. Anti-Wrinkle Delay Time .....	17
e. Maximum Guard On Time .....	17
P. Special Cool Down Program/Selection (Patent No. 5,161,314) .....	18

## SECTION IV

<b>OPERATING INSTRUCTIONS .....</b>	<b>19</b>
A. Operating Sequence .....	19
1. Preprogrammed Cycles .....	19
2. Manually Loaded Cycles .....	21
B. Operating Notes .....	23

## SECTION V

<b>L.E.D. DISPLAY/CODES .....</b>	<b>24</b>
A. L.E.D. Display Operating Status .....	24
B. Phase 5 OPL Microprocessor Controller (Computer) L.E.D. Displays .....	25
C. L.E.D. (Light Emitting Diode) Codes .....	26

## SECTION VI

<b>PROGRAMMING INSTRUCTIONS .....</b>	<b>28</b>
A. Introduction to Programming .....	28
B. Programming Flowcharts .....	29
Flowchart Titles .....	30

## SECTION VII

<b>FACTORY PRESET PARAMETERS/PROGRAMS .....</b>	<b>54</b>
A. Parameters (Programs) Preset By Factory For Non-Reversing Dryers .....	54
B. Parameters (Programs) Preset By Factory For ( <i>Optional</i> ) Reversing Dryers .....	55

## SECTION VIII

<b>SYSTEM PARAMETER/PROGRAM LOCATION CHART .....</b>	<b>56</b>
--	-----------

## SECTION IX

<b>PHASE 5 OPL PROGRAMMING LIMITS .....</b>	<b>57</b>
A. Preprogrammed Cycles .....	57
B. System Parameters (Program Locations) .....	57
C. Fixed Parameters .....	58

**SECTION X**

**PHASE 5 AUTO CYCLE (Patent No. 4,827,627) ..... 59**  
    “A” and “B” Factor Parameters  
        for *Current Production Dryer Models* ..... 59  
    “A” and “B” Factor Parameters  
        for *Past Production Dryer Models* ..... 60

**SECTION XI**

**PHASE 5 OPL SYSTEM DIAGNOSTICS ..... 61**  
    A. Diagnostic (L.E.D. [Light Emitting Diode] Display) Failure Codes ..... 61  
    B. L.E.D. Display Failure Indicators ..... 62  
    C. Phase 5 OPL Microprocessor Controller (Computer) Relay Output L.E.D. Indicators ..... 63

**SECTION XII**

**OPTIONAL 9 VOLT BATTERY BACK-UP ..... 66**

# SECTION I

## INTRODUCTION

### PHASE 5 “ON-PREMISE LAUNDRY” (OPL) MICROPROCESSOR DRYING SYSTEM

The **American Dryer Corporation’s** Phase 5 “On-Premise Laundry” (OPL) Drying System has been designed with super performance in mind to provide for better temperature regulation, efficiency, performance, consistency, and faster drying times.

Specifically, **ADC’s** Phase 5 OPL System’s higher performance emanates from the following enhancements:

1. The ability to better control the temperature inside the basket (tumbler) throughout the various cycles.
2. The Phase 5 OPL microprocessor controller (computer) responds immediately to any temperature variations from temperature selection, which enables the control temperature band to be +/- 3° F (2° C) from this selected drying temperature. The narrower temperature control band greatly increases system efficiency, since it takes less heat to maintain a given temperature than to rise to a given temperature.

Among its many amenities, **ADC’s** Phase 5 OPL Drying System has a true Automatic Drying Cycle. The Phase 5 OPL Automatic Drying Cycle (**Patent No. 4,827,627**) principle is based on one (1) of the most fundamental laws of thermodynamics which governs the flow of heat in thermal systems.

Utilizing this microprocessor technology, the user simply has to place the load in the dryer and push one (1) single button to start drying cycle. The Phase 5 OPL microprocessor controller (computer) will directly monitor the moisture content in the load and stop the drying cycle automatically when the selected percentage of extraction (dryness level) is reached.

The **ADC** Phase 5 OPL Automatic Drying Cycle (**Patent No. 4,827,627**) virtually eliminates **ALL** guess work. The Phase 5 OPL microprocessor controller (computer) determines how much drying time is needed and compensates for various types of fabrics and load sizes, thus, avoiding damage to fabrics by over drying, as well as avoiding wasted time and energy for any given load. Once the Phase 5 microprocessor controller (computer) determines the load is dry, the microprocessor controller (computer) will go into Cool Down Cycle (**Patent No. 4,827,627**) until the preprogrammed time or temperature is reached, and then shuts the dryer off automatically.



# SECTION II

## FEATURES

- A. **DEPENDABLE MICROPROCESSOR SOLID STATE INTEGRATED CIRCUITRY** - to eliminate as many moving parts as possible.
- B. **PROGRAM CHANGES ARE EASILY MADE AT THE KEYBOARD** - actual programs are viewed at the L.E.D. (light emitting diode) display for verification.
- C. **AUTOMATIC DRYING CYCLE (Patent No. 4,827,627)** - computerized monitoring of load dryness for precise, fast, and efficient drying.
- D. **TIMED (MANUAL) DRYING CYCLE** - for special loads, programming allows for a specific amount of time in minutes for both drying and cool down cycles.
- E. **PREPROGRAMMED CYCLES** - the Phase 5 OPL microprocessor controller (computer) can store in its memory six (6) preprogrammed cycles in either the Automatic Drying Mode (**Patent No. 4,827,627**) or Manual Drying Mode.
- F. **MANUALLY LOADED CYCLES** - for occasional or one (1) time special loads, the user can set a specific program in either the Automatic Drying Cycle (**Patent No. 4,827,627**) or Timed Mode.
- G. **VARIABLE (PROGRAMMABLE) FABRIC/TEMPERATURE SELECTIONS** - accommodates the type of fabric to be dried.
- H. **CONTROLLED COOL DOWN PROGRAM** - helps eliminate wrinkled loads.
- I. **L.E.D. (LIGHT EMITTING DIODE) DISPLAY** - informs user of cycle status, programs, and displays important diagnostic and fault codes.
- J. **ANTI-WRINKLE PROGRAM** - helps keep items wrinkle-free when they are not removed from the dryer promptly at the end of the drying and cooling cycles.
- K. **DIAGNOSTICS** - major circuits, including the door switch, microprocessor temperature sensor, motor, and heat output circuits are monitored.
- L. **AUDIBLE TONE SIGNAL** - a tone will sound for each keyboard (touchpad) entry. Additionally, the tone will sound at the end of the drying and cooling cycles to indicate the cycle is complete.
- M. **TEMPERATURE CONVERSION STATUS** - temperature-related programs can be set in either Fahrenheit (°F) or Celsius (°C). **ALL** temperatures will automatically convert to the corresponding values (+/- 1°) when changes are made.
- N. **HI-TEMPERATURE PROTECTION** - if the Phase 5 OPL microprocessor controller (computer) senses that the temperature in the basket (tumbler) has reached 221° F (105° C), it will shut the dryer down completely, and a default code will appear in the L.E.D. (light emitting diode) display indicating an overheating problem.
- O. **CYCLE PREVIEW** - entire dryer parameters (programs) or the preprogrammed cycles are displayed for verification upon a coded entry to the keyboard (touchpad).

- P. **REVERSING OPTION** - helps eliminate wrinkling due to the balling up or tangling of large items. Certain models have the *reversing option* where the basket (tumbler) will turn in the forward direction for two (2) minutes, stop for 5-seconds, and then proceed in the reverse direction for two (2) minutes. This process is repeated throughout the drying and cooling cycles.
- Q. **ROTATION SENSOR SELECTION** - this feature allows the Phase 5 OPL microprocessor controller (computer) to monitor the rotation of the basket (tumbler). If the basket (tumbler) should fail to rotate, the Phase 5 OPL microprocessor controller (computer) will disable **ALL** outputs, stopping the dryer and a failure code will be displayed on the L.E.D (light emitting diode).
- R. **SPECIAL COOL DOWN PROGRAM (Patent No. 4,827,627)** - this feature resides in preprogrammed Cycle “F,” and allows the Phase 5 OPL microprocessor controller (computer) to limit the cooling process to 10° F (5° C) per minute, and can be used for fabrics that need a controlled Cool Down Cycle (i.e., VISA®).
- S. **BATTERY BACK-UP (OPTIONAL)** - this *option* allows the Phase 5 OPL microprocessor controller (computer) to maintain its operating status should a momentary power interruption occur while the dryer cycle is in progress.

# SECTION III

## PROGRAM SELECTIONS

### A. PREPROGRAMMED CYCLES

The Phase 5 OPL microprocessor controller (computer) can store in its memory six (6) preprogrammed cycles (keys “A” through “F” on the keyboard [touchpad]). This allows the user to have the six (6) most commonly used cycles, requiring only the push of a single keyboard (touchpad) entry to start the dryer.

These preprogrammed cycles can be set in either the Automatic Drying Cycle/Mode (**Patent No. 4,827,627**) where the drying cycle will end when the percentage of extraction (dryness level) programmed has been reached or in the Timed (Manual) Drying Cycle (Mode) where the dryer will operate for the specific drying time programmed. These cycles can be programmed in any combination.

Once the drying cycle is completed, the Phase 5 OPL microprocessor controller (computer) then goes into the Cool Down Cycle where the articles are tumbled in room temperature air. Once the programmed Cool Down Cycle is completed, the dryer will shut off automatically.

With the Anti-Wrinkle Program active, when the Cooling Cycle is completed and the dryer is shut off, if the main door is not opened, the load will be tumbled without heat (i.e., for 20-seconds every 90-seconds). This process is repeated until either the main door is opened or ten (10) minutes has elapsed, whichever comes first.

#### **PREPROGRAMMED CYCLE SELECTIONS:**

1. Automatic Drying Cycle/Mode - (**Patent No. 4,827,627**)
  - a. For *optional reversing models*, the Phase 5 OPL microprocessor controller (computer) can be programmed to reverse or not reverse (single direction rotation).
  - b. Anti-Wrinkle Program - active or non-active.
  - c. Drying Temperature - programmable from 160° F to 200° F (71° C to 93° C) in one-degree increments.
  - d. Dryness Level (percentage of extraction) - programmable from ninety percent (90%) to one hundred percent (100%) in one percent (1%) increments.
  - e. Cool Down Time - programmable from 0 to 99 minutes in one (1) minute increments.
  - f. Cool Down Temperature - programmable from 70° F to 100° F (20° C to 37° C) in one-degree increments.
2. Timed (Manual) Cycle (Mode)
  - a. For *optional reversing models*, the Phase 5 OPL microprocessor controller (computer) can be programmed to reverse or not reverse (single direction rotation).
  - b. Anti-Wrinkle Program - active or non-active.

- c. Drying Time - programmable from 0 to 99 minutes in one (1) minute increments.
- d. Drying Temperature -programmable from 100° F to 200° F (37° C to 93° C) in one-degree increments.
- e. Cool Down Time - programmable from 0 to 99 minutes in one (1) minute increments.
- f. Cool Down Temperature -programmable from 70° F to 100° F (20° C to 37° C) in one-degree increments.
- g. For *optional reversing models*, the Spin Time can be programmed from 30-seconds to 120-seconds in one-second increments.
- h. For *optional reversing models*, the Dwell (Stop) Time can be programmed from 5-seconds to 10-seconds in one-second increments.

**ALL** six (6) preprogrammed cycles have been programmed by the factory as outlined on **page 54** and **page 55**. However, even though these are the most common cycles used, they **should be** reviewed to ensure they meet the location application or needs. Should changes be found necessary, refer to the Programming Section of this manual.

## **B. MANUALLY LOADED CYCLES**

For occasional or one-time special loads, the operator **must set** the specific programs needed. This cycle is not stored within the Phase 5 OPL microprocessor controller (computer) and **must be** entered each and every time.

The Manually Loaded Cycle can be set in either the Automatic Drying Cycle/Mode (**Patent No. 4,827,627**) or the Timed (Manual) Drying Cycle (Mode).

### **MANUALLY LOADED CYCLE SELECTIONS:**

1. Automatic Drying Cycle/Mode (Patent No. 4,827,627)
  - a. Drying Temperature - programmable from 160° F to 200° F (71° C to 93° C) in one-degree increments.
  - b. Dryness Level (percentage of extraction) - programmable from 90% less dry to 100% more dry in one percent (1%) increments.
  - c. For *optional reversing models*, depending on what the system parameter (program) is set for, the operator has the choice of reverse or no reverse (single direction rotation).
2. Manually Drying Cycle (Mode)
  - a. Drying Time - programmable from 0 to 99 minutes in 1 minute increments.
  - b. Cool Down Time - programmable from 0 to 99 minutes in 1 minute increments.
  - c. Drying Temperature - programmable from 100° F to 200° F (37° C to 93° C) in one-degree increments.

## C. AUTOMATIC DRYING CYCLE/MODE (Patent No. 4,827,627)

In this mode, the Phase 5 OPL microprocessor controller (computer) determines how much drying time is needed and compensates for various types of fabric and load sizes, **ALL** automatically. The Phase 5 OPL microprocessor controller (computer) accomplishes this by calculating the dryness level (percentage of extraction) using the temperature selected, as well as, the “A” and “B” factors preset by the factory.

The Phase 5 OPL microprocessor controller (computer) monitors the first three (3) heat peaks (slopes), at which time it calculates the “A” Slope and “B” (heat loss) factors along with the percentage of extraction selected. When the Phase 5 OPL microprocessor controller (computer) determines that **ALL** the factors are met, the drying cycle will end, and the dryer will go into the Cool Down Cycle.

### **AUTOMATIC DRYING CYCLE/MODE (PATENT NO. 4,827,627) SELECTIONS:**

1. Drying Temperature - programmable from 160° F to 200° F (71° C to 93° C) in one-degree increments.
2. Dryness Level (percentage of extraction) - programmable from 90% (less dry) to 100% (more dry) in one percent (1%) increments.
3. Cool Down Time - programmable from 0 to 99 minutes in one (1) minute increments.
4. Cool Down Temperature - programmable from 70° F to 100° F (20° C to 37° C) in one-degree increments.
5. Factors (System Parameter Program Location 2 [Key “2”])
  - a. Factor “A” Slope Program - the Phase 5 OPL microprocessor controller (computer) monitors how long it takes to get to the selected temperature.
    - 1) Program selections are 1 through 9 in increments of one (1).
  - b. Factor “B” Heat Loss (offset) Program - this factor setting is dependent upon the model dryer and the type of heating unit.
    - 1) Program selections are 1 through 99 in increments of one (1).

The “A” and “B” Factors have been preprogrammed by the factory as outlined on **page 54** and **page 55** and **SHOULD NOT BE CHANGED** unless the Phase 5 OPL microprocessor controller (computer) should fail and is being replaced. The replacement Phase 5 OPL microprocessor controller (computer) **MUST BE PROGRAMMED** for the particular dryer model and heating unit as shown in the “A” and “B” Factor table on **page 59** and **page 60** of this manual.

6. For **Optional Reversing Models** - the Phase 5 OPL microprocessor controller (computer) can be programmed to reverse or not reverse (single direction rotation).
7. When used in conjunction with the Preprogrammed Cycles, programming allows the Anti-Wrinkle Program to be active or non-active.

## D. TIMED (MANUAL) DRYING CYCLE (Mode)

This drying cycle is intended for special loads where a specific amount of drying time and cooling time is needed, especially for fine, delicate items which require very low temperatures and long drying and/or cool down time periods.

### **TIMED (MANUAL) CYCLE (MODE) SELECTIONS:**

1. Drying Time - programmable from 0 to 99 minutes in one (1) minute increments.
2. Cool Down Time - programmable from 0 to 99 minutes in one (1) minute increments.
3. Drying Temperature - programmable from 100° F to 200° F (37° C to 93° C) in one-degree increments.
4. For *optional reversing models*, the Phase 5 OPL microprocessor controller (computer) can be programmed to reverse or no reverse (single detection rotation).
5. When used in conjunction with the preprogrammed cycles, programming allows the Anti-Wrinkle Program to be active or non-active.

## E. TEMPERATURE SELECTIONS (Drying Temperatures)

### **OPERATING TEMPERATURE SELECTIONS:**

1. Automatic Drying Cycle/Mode (**Patent No. 4,827,627**) - programmable from 160° F to 200° F (71° C to 93° C) in one-degree increments.
2. Timed (Manual) Drying Cycle (Mode) - programmable from 100° F to 200° F (37° C to 93° C) in one-degree increments.

## F. COOL DOWN CYCLE

### **COOL DOWN CYCLE SELECTIONS:**

1. Preprogrammed Cycles
  - a. Automatic Drying Cycle/Mode (**Patent No. 4,827,627**)
    - 1) Cool Down Time - 0 to 99 minutes in one (1) minute increments.
    - 2) Cool Down Temperature - 70° F to 100° F (20° C to 37° C) in one-degree increments.
  - b. Timed (Manual) Drying Cycle (Mode)\*
    - 1) Cool Down Time - 0 to 99 minutes in one minute increments.

**\*NOTE:** The Cool Down Cycle will run either until the Cool Down Temperature is reached or until the Cool Down Time has expired, whichever comes first.

## 2. Manually Loaded Cycles

- a. Automatic Drying Cycle/Mode\* (**Patent No. 4,827,627**)
  - 1) Cool Down Time - 0 to 99 minutes in 1 minute increments.
  - 2) Cool Down Temperature - 70° F to 100° F (20° C to 37° C) in one-degree increments.
- b. Timed (Manual) Drying Cycle (Mode)\*

**\*NOTE:** The Cool Down Cycle will run either until the Cool Down Temperature is reached or until the Cool Down Time has expired, whichever comes first.

## G. L.E.D. (LIGHT EMITTING DIODE) DISPLAY

The L.E.D. (light emitting diode) display informs the user of cycle status, program verification, and displays important diagnostic and fault codes. A complete listing of the various display codes and their meanings are shown on **page 26** and **page 27** of this manual.

### **DISPLAY SELECTIONS:**

#### 1. Display Status

- a. While the dryer cycle is in progress, programming allows the L.E.D. (light emitting diode) display to read only the Cycle In Progress or only the Basket (tumbler) Temperature. Programming also allows a flash display whereby the L.E.D. display will flash back and forth between Cycle In Progress and Temperature.
  - 1) Both the Cycle In Progress and Temperature can be programmed to flash from 1-second to 15-seconds in one-second increments.

#### 2. Cycle in Progress Display Status

- a. Automatic Drying Cycle/Mode (**Patent No. 4,827,627**) - the L.E.D. (light emitting diode) display reads Percentage of Extraction in the cycle in progress and then Cool Down.
- b. Timed (Manual) Cycle (Mode) - the L.E.D. (light emitting diode) display reads Drying Time and/or Cool Down Time counting downwards as time elapses.

#### 3. Indicator Dots on the L.E.D. (Light Emitting Diode) Display

- a. The indicator dots are an indicator as to the various Phase 5 OPL microprocessor controller (computer) output functions. Additionally, there are also indicators on the back side of the Phase 5 OPL microprocessor controller (computer) to verify the outputs of the relay.

- 1) Drive Motor (blower motor on reversing models).
- 2) Heat On (active).
- 3) Reversing models have indicators for the forward (clockwise [CW]) basket (tumbler) rotation and reverse (counterclockwise [CCW]) basket (tumbler) rotation.

## H. CYCLE IN PROGRESS TEMPERATURE DISPLAY

While the dryer cycle is in progress, the temperature in the basket (tumbler) can be displayed by pressing the “ENTER/START” key. The temperature will be displayed in either Fahrenheit (°F) or Celsius (°C), depending on how the temperature conversion status program is set.

## I. TEMPERATURE CONVERSION STATUS

Temperature related programs are programmable to be operated in either Fahrenheit (°F) or Celsius (°C). Programs affected are:

1. Temperature Display Mode
2. Temperature Selections (drying temperatures)
3. Cool Down Temperatures

**IMPORTANT:** When changing the temperature conversion status from Fahrenheit or Celsius or vice versa, **ALL** the Temperature Selections and Cool Down Temperatures **will be** changed accordingly. The Phase 5 OPL microprocessor controller (computer) automatically calculates and converts the temperatures in these programs to the previously set value. For example, when changing from °F to °C, if the pre-programmed Cycle “A” drying temperature was set for 160° F (71° C), the Phase 5 OPL microprocessor controller (computer) will change to 160° F (71° C) +/- one (1) degree Celsius.

## J. ANTI-WRINKLE PROGRAM

This program keeps items wrinkle-free when they are not removed from the dryer promptly at the end of the drying cycle and/or cooling cycle.

When this program is active (on) and the drying cycle and cooling cycle is completed, the dryer will shut off, the tone will sound, and the L.E.D. (light emitting diode) display will read “dONE.” If the door is not opened, the Phase 5 OPL microprocessor controller (computer) will wait until the Anti-Wrinkle Guard Delay Time “GdLY” has expired at which time the basket (tumbler) will rotate (without heat) for the programmed Guard On Time “G on-tInE.” The Phase 5 OPL microprocessor controller (computer) will repeat this process until the Maximum Guard Time “MGrd” has expired or until the door is opened, whichever comes first.



## **ANTI-WRINKLE PROGRAM SELECTIONS:**

1. Anti-Wrinkle Guard Active or No Anti-Wrinkle Guard
2. Guard Delay Time
  - a. Programmable from 10-seconds to 255-seconds in one-second increments.
3. Guard On Time
  - a. Programmable from 10-seconds to 60-seconds in one-second increments.
4. Maximum Guard Time
  - a. Programmable from 1 minute to 99 minutes in 1 minute increments.

## **K. AUDIBLE TONE SIGNAL**

A tone will sound for each keyboard (touchpad) entry made. The tone will also sound at the end of the drying cycle and cooling cycle to indicate that the cycle is complete. When the Anti-Wrinkle Program is active, programming allows for the elimination of the tone during the Anti-Wrinkle Program, with the exception of the keyboard (touch pad) entry tone, which is fixed at approximately 1-second. Programming allows the tone to be set from 0 to 15-seconds in 1-second increments.

## **L. PREPROGRAMMED CYCLE PREVIEW**

The parameters (programs) of the preprogrammed cycles can be displayed for verification. To view a preset program (parameter), simply press the “ENTER/START” key and the desired preset program (parameter). The L.E.D. (light emitting diode) display will read the parameters (programs) set, then return to the “REAdY” display mode.

## **M. REVERSING OPTION**

This program helps eliminate wrinkling due to balling up or tangling of large items.

### **REVERSING OPTION SELECTIONS:**

1. Reverse or No Reverse (preprogrammed cycles ONLY)
2. Select Reverse or Always Reverse (manually loaded cycles ONLY)
3. Basket (Tumbler) Spin Time and Dwell (Stop) Time
  - a. Fixed in the Automatic “**AUTO**” Mode and **CANNOT BE CHANGED.**
    - 1) Spin Time - Forward - 2-1/2 minutes, Reverse - 2 minutes.
    - 2) Dwell (Stop) Time - 5-seconds.

4. Basket (Tumbler) Spin Time and Dwell (Stop) Time
  - a. Programmable in the Manual Mode.
    - 1) Spin Time - programmable from 30-seconds to 120-seconds in one-second increments.
    - 2) Dwell (Stop) Time - programmable from 5-seconds to 10-seconds in one-second increments.

## N. DIAGNOSTICS

Three (3) major circuits of the Phase 5 OPL microprocessor controller (computer) are monitored. They are as follows:

1. Microprocessor Heat Sensor Circuit fault will shut the drying cycle off, and the L.E.D. (light emitting diode) display will read “**dSFL**.”
2. If there is a fault in the Door Switch Circuit, the L.E.D. (light emitting diode) display will read “**door**.” This “**door**” display code will also appear if while a cycle is in progress, the main door was opened and not closed, and a keyboard (touchpad) entry was made.
  - a. There is a red indicator light labeled “DOOR” on the back side of the Phase 5 OPL microprocessor controller (computer) to help in diagnosing this specific fault/failure.
3. If the Basket (tumbler) Fails To Rotate, a signal will appear on the L.E.D. (light emitting diode) display (“**SEFL**”) along with an audible tone.

High Temperature Protection - if the Phase 5 OPL microprocessor controller (computer) senses that the temperature in the basket (tumbler) has exceeded 220° F (104° C), it will shut the dryer down completely, and the default code “**Hot**” will appear in the L.E.D. (light emitting diode) display, indicating that this an overheating problem. The “**Hot**” default code will be displayed until the temperature has dropped down to 220° F (104° C) or lower, and then the “CLEAR/STOP” key **must be** pressed, at which time the L.E.D. display will return to “FILL.”

## O. SYSTEM PARAMETERS (PROGRAM LOCATIONS/REVIEW)

The system parameters are the programs which, once set by the factory, rarely need to be changed in the field. These system parameters (programs) are stored in the memory and catalogued as program locations (Keys “2,” “5,” “8,” and “0”).

**ALL** of the parameters affect the manually loaded program cycles, and some affect the Manually Loaded Program Cycles. The information on **page 56** shows the parameters of each program location, as well as what cycles are affected. The programming limits of each program location are shown on **page 57** and **page 58**. Additionally, the parameters preset by the factory are shown on **page 54** and **page 55**.

Review system parameters (programs) with one (1) touch of the keyboard (touch pad) key “8.” The Phase 5 OPL microprocessor controller (computer) will automatically display Program Locations “2,” “5,” “8,” and “0.”

1. Program Location 2 (Key “2”)

a. Temperature Conversion Status - this program controls whether the temperature-related programs **will be** operated in Fahrenheit (° F) or Celsius (° C). The programs affected are as follows:

- 1) Temperature Display Mode.
- 2) Temperature Selections (drying temperatures).
- 3) Cool Down Temperatures.

**IMPORTANT:** The Phase 5 OPL microprocessor controller (computer) automatically calculates and converts the temperatures in these programs to the previously set value. For example, when changing from ° F to ° C, if the preprogrammed Cycle “A” drying temperature was set for 160° F (71° C), the Phase 5 OPL microprocessor controller (computer) will change to 160° F (71° C) +/- one-degree Celsius.

b. Select Reverse - for *optional reversing models*, this program allows the operator to have a choice of Reverse or No Reverse (single direction rotation) basket (tumbler) action in the manually loaded cycles **ONLY**.

- 1) Always Reverse (“**ArEu**”) - in this operational mode the operator has no choice. Any manually loaded cycle entered **will be** a reversing cycle.
- 2) Select Reverse (“**SrEu**”) - when this parameter (program) is chosen, the Phase 5 OPL microprocessor controller (computer) will prompt the operator to decide whether or not the manually loaded cycle entered is to be a reversing cycle.

c. Rotation Sensor Selection - this option allows the Phase 5 OPL microprocessor controller (computer) to monitor the rotation of the basket (tumbler).

d. Factor “A” (Slope Program) - this parameter (program) is one of the factors that the Phase 5 OPL microprocessor controller (computer) uses when programmed in the Automatic Drying Cycle/Mode (**Patent No. 4,827,627**). This factor pertains to the thermal characteristics of each model dryer. In this Slope Program, the Phase 5 OPL microprocessor controller (computer) monitors how long it takes for the dryer to get to the selected temperature. The range of adjustment of this slope factor is 1 through 9 in increments of one (1).

- 1) This slope factor has been programmed by the factory as outlined on **page 54** and **page 55** and **SHOULD NOT BE CHANGED** unless the Phase 5 OPL microprocessor controller (computer) should fail and is being replaced. The replacement Phase 5 OPL microprocessor controller (computer) **MUST BE PROGRAMMED** for the particular dryer model and heating unit as shown in the “A” and “B” Factor table/chart on **page 59** and **page 60** of this manual.

e. Factor “B” (Heat Loss [offset] Program) - this parameter/program is one (1) of the factors that the Phase 5 OPL microprocessor controller (computer) uses when programmed in the Automatic Drying Cycle/Mode (**Patent No. 4,827,627**). This factor also pertains to the thermal characteristics of each model dryer. This factor setting is dependent upon the model dryer and the type of heating unit. The range of adjustment of this slope factor is 1 through 99 in increments of one (1).

1) This factor (Factor “B”) has been programmed by the factory as outlined on **page 54** and **page 55** and **SHOULD NOT BE CHANGED** unless the Phase 5 OPL microprocessor controller (computer) should fail and is being replaced. The replacement Phase 5 OPL microprocessor controller (computer) **MUST BE PROGRAMMED** for the particular dryer model and heating unit as shown in the “A” and “B” Factor table/chart on **page 59** and **page 60** of this manual.

## 2. Program Location 5 (Key “5”)

a. Flash Display Status - this parameter (program) allows for the L.E.D. (light emitting diode) display to read ONLY the Cycle In Progress or ONLY the Basket (tumbler) Temperature, while a cycle is in progress. This is referred to as No Flash (“nFLS”). When this parameter is set to Flash (“FLS”), the L.E.D. display will flash (alternate) back and forth between the Cycle In Progress and the Temperature.

b. Flash Cycle Display Time - if the Flash Display (“FLS”) was chosen at the beginning of Program Location 5 (Key 5), the operator will now be prompted to enter the time the L.E.D. (light emitting diode) display will read Cycle In Progress before changing to the Basket (tumbler) Temperature. The Flash Cycle Display Time is programmable from 1 to 15-seconds in one-second increments.

c. Flash Temperature Display Time - if the Flash Display (“FLS”) was chosen at the beginning of Program Location 5 (Key 5), the operator will now be prompted to enter the time the L.E.D. (light emitting diode) display will read Cycle In Progress before changing to the Basket (tumbler) Temperature. The Flash Cycle Display Time is programmable from 1 to 15-seconds in one-second increments.

## 3. Program Location 8 (Key “8”)

a. Cool Down Time - this parameter (program) affects ONLY the Automatic Drying Cycle (**Patent No. 4,827,627**) when the manually loaded cycle is selected. This Auto Cool Down Time is programmable from 0 to 99 minutes in one (1) minute increments.

b. Cool Down Temperature - this parameter (program) affects ONLY the Automatic Drying Cycle (**Patent No. 4,827,627**) when the manually loaded cycle is selected. The Cool Down Temperature is programmable from 70° F to 100° F (20° C to 37° C) in one-degree increments.

c. Spin Time - this parameter (program) is fixed at 2 minutes in the Automatic Mode and programmable in the Manual Mode. This Spin Time is programmable (in the Manually Loaded Cycle ONLY) from 30-seconds to 120-seconds in one-second increments.

- d. Dwell (Stop) Time - this parameter (program) is fixed at 5-seconds in the Automatic Mode and programmable in the Manual Mode. This Dwell (Stop) Time is programmable (in the Manually Loaded Cycle ONLY) from 5-seconds to 10-seconds in one-second increments.
- e. Buz (Tone) Time - this parameter allows the operator to adjust the time, the signal tone sounds from 0 to 15-seconds in one-second increments. This parameter (program) affects the tone at the end of the drying cycle and cooling cycle, as well as, at the end of the Guard On Time when the Anti-Wrinkle Program is active (“Grd”).

#### 4. Program Location 0 (Key “0”)

- a. Anti-Wrinkle Program Activation - this parameter (program) controls whether or not the Anti-Wrinkle Program (“Grd”) will be active (on) for manually loaded cycles ONLY.
- b. Buz Time (Anti-Wrinkle Tone) - when the Anti-Wrinkle Program is active (“Grd”), this parameter (program) allows the operator the option to have the tone (buzzer) sound at the end of each Anti-Wrinkle On Time Cycle. The Buz (tone) Time is programmable from 0 to 15-seconds in one-second increments (refer to Program Location 8 [Key “8”]).
- c. Anti-Wrinkle On Time - this parameter (program) controls the amount of time that the basket (tumbler) will turn (spin/rotate) without heat when the Anti-Wrinkle Program is active (“Grd”). The Anti-Wrinkle On Time is programmable from 10-seconds to 60-seconds in one-second increments.
- d. Anti-Wrinkle Delay Time - when the Anti-Wrinkle Program is active (“Grd”), this parameter (program) controls the Dwell (Stop) and activation of the Anti-Wrinkle On Time. The Anti-Wrinkle Delay Time (“GdLY”) is programmable from 10-seconds to 255-seconds in one-second increments.
- e. Maximum Guard On Time - this parameter (program) controls the maximum time that the Anti-Wrinkle Program will be in progress. The Maximum Guard On Time (MGrd”) is programmable from 1 minute to 99 minutes in one (1) minute increments.

**P. SPECIAL COOL DOWN PROGRAM/SELECTION (Patent No. 5,161,314)**

This unique Cool Down Program/Selection is specifically designed to limit the amount of cooling that occurs during the Cool Down Cycle. During the Special Cool Down Cycle process, the Phase 5 OPL microprocessor controller (computer) cycles the heat at various intervals to achieve a gradual cool down of approximately 10° F (-12° C) per minute. Hence, this program allows the fabric to cool at a limited and controlled rate, thus allowing the material to relax without excessive wrinkling, especially with fabrics that are easily shocked and/or respond adversely to great changes in temperature (i.e., Visa®).

This Special Cool Down Program/Selection (**Patent No. 5,161,314**) can ONLY be found in preprogrammed Cycle “F” when programmed as a “Timed Cycle” and ONLY when the Phase 5 OPL microprocessor controller (computer) has been programmed for Special Cool Down (“SC”), as described in the **Programming Section** of this manual.

**NOTE:** Unless specified at the time of ordering, the Phase 5 OPL microprocessor controller (computer) has been programmed with this Special Cool Down “Not Active” (“nSC”).

With this Special Cool Down “Active” (“SC”), the Cool Down Temperature limits differ than if it were a normal cycle. The Special Cycle “Cool Down Time” or minimum limits are governed by the “drying temperatures” selected.

DRYING TEMPERATURE RANGE		MINIMUM LIMIT
180° F to 200° F	82° C to 93° C	10 Minutes
150° F to 179° F	65° C to 82° C	7 Minutes
100° F to 149° F	37° C to 65° C	5 Minutes

Although this Special Cool Down Program/Selection (**Patent No. 5,161,314**) is designed primarily for gas heated dryers, it can be used for both electric heated and steam heated dryers, however, the results will vary.

**IMPORTANT:** During a cycle, the Special Cool Down Cycle *should be* allowed to run its entire cycle without any interruption (i.e., the main door *should not be* opened), so that the material being dried is properly cooled...otherwise serious injury may result.

**NOTES:** To utilize this unique “Special Cool Down Cycle,” the items below *must be* kept in mind...

1. Activate the Special Cool Down Cycle as explained in the **Programming Section** of this manual.
2. Preprogrammed Cycle “F” *must be* set in the “Timed Mode.”
3. Preprogrammed Cycle “F” *should be* changed to reflect the programming limits outlined above.

# SECTION IV

## OPERATING INSTRUCTIONS

The Phase 5 OPL microprocessor controller (computer) allows the operator to choose from six (6) preprogrammed cycles (Key “A” through Key “F”) which, unless otherwise specified at the time of ordering the dryer, has been preprogrammed by the factory with the parameters (programs) shown on [page 54](#) and [page 55](#). Additionally, for occasional or one-time special loads, the manually loaded cycles can be used where the **operator must set** the specific program(s) needed.

**NOTE:** Refer to **Section III** of this manual for a complete explanation of the various cycles/selections available.

After the load is put into the basket (tumbler) and the main door is closed, determine which cycle will suit the application (type of load). We recommend using the Automatic Drying Cycle (**Patent No. 4,827,627**) for most loads. This cycle provides for the best drying in the shortest time, **ALL** automatically.

### A. OPERATING SEQUENCE

#### 1. Preprogrammed Cycles

##### a. Automatic Drying Cycle (**Patent No. 4,827,627**)

- 1) L.E.D. (liquid emitting diode) display reads “FILL” (no cycle in progress).
- 2) Press the letter on the keyboard (touchpad) corresponding to the cycle desired (i.e., Key “A”)...
  - a) The dryer will then start (rotate).
- 3) The L.E.D. (light emitting diode) display reads Cycle In Progress and Cycle Status (i.e., “dr00”) meaning that the dryer is in the Drying Cycle (Mode). During the drying cycle, the Phase 5 OPL Microprocessor Controller (computer) is monitoring the amount of moisture in the load. Approximately half way through the drying cycle, the Cycle Status portion of the L.E.D. display will change from “00” to the percentage of extraction it senses (i.e., “68”). The Cycle Status of the L.E.D. display will change and count upwards until the percentage of extraction programmed is reached.

**NOTE:** To stop the dryer at any time, open the main door. To continue the cycle, close the main door and press the “PRESS START” key. The dryer will continue from where it left off...or the dryer may also be stopped by pressing the “CLEAR/STOP” key. However, the cycle that was in progress **will be cancelled**, and the L.E.D. (light emitting diode) display will return to the “FILL” (no cycle in progress) Mode.

- 4) Once the preprogrammed percentage of extraction (dryness level) is reached (i.e., “100”), the drying cycle will end, and the Cycle In Progress portion of the L.E.D. (light emitting diode) display will read “CL,” meaning that the dryer is now in the Cool Down Cycle (Mode). The Cycle Status portion of the L.E.D. display will continue to show the percentage of extraction. However, it serves no purpose in the Cool Down Cycle (Mode).

- 5) Once the Cool Down Cycle is completed, the dryer will shut off, the tone (buzzer) will sound (i.e., 7-seconds), and the L.E.D. (light emitting diode) display will read “donE.” The L.E.D. display will continue to read “donE” until the main door is opened.
- 6) If the Anti-Wrinkle Program is active (on), once the drying cycle and cooling cycles are completed and the L.E.D. display reads “donE” the Phase 5 OPL microprocessor controller (computer) will proceed into the Anti-Wrinkle Program (Mode). If the main door is not open within the Anti-Wrinkle Delay Time (i.e., 90-seconds), the basket (tumbler) will rotate (without heat) for the programmed Anti-Wrinkle On Time (i.e., 20-seconds). The Phase 5 OPL microprocessor controller (computer) will repeat this process until the programmed Maximum Anti-Wrinkle On Time has expired (i.e., 10 minutes) or until the main door is opened, whichever comes first. The L.E.D. display will continue to read “donE” until either the main door is opened or the Maximum Anti-Wrinkle On Time has expired, at which time the L.E.D. display will read “FILL” (no cycle in progress).

b. Timed (Manual) Drying Cycle

- 1) L.E.D. (light emitting diode) display reads “FILL” (no cycle in progress).
- 2) Press the letter on the keyboard (touchpad) corresponding to the cycle desired (i.e., Key “D”).
- 3) The dryer will then start (rotate).
- 4) The L.E.D. display will show Cycle In Progress and Cycle Status (Mode) for 40 minutes. During the Drying Cycle, the Cycle Status time will count downward until the drying time programmed has expired.

**NOTE:** To stop the dryer at any time, open the main door. To continue the cycle, close the main door and press the “PRESS START” key. The dryer will continue from where it left off...or the dryer may also be stopped by pressing the “CLEAR/STOP” key. However, the cycle that was in progress **will be cancelled**, and the L.E.D. (light emitting diode) display will return to the “FILL” (no cycle in progress) Mode.

- 5) When the programmed drying time has expired, the Phase 5 OPL microprocessor controller (computer) will proceed into the Cool Down Cycle (Mode), and the Cycle In Progress portion of the L.E.D. (light emitting diode) display will read “CL.” The Cycle Status portion of the L.E.D. display will read the Cool Down Time (i.e., 6 minutes) and count downward until this time has expired.
- 6) Once the Cool Down Cycle is completed, the dryer will shut off, and the L.E.D. display will read “donE.” The L.E.D. display will continue to read “donE” until the main door is opened.
- 7) If the Anti-Wrinkle Program is active (on), once the Drying Cycle and Cooling Cycle are completed and the L.E.D. (light emitting diode) display reads “donE,” the Phase 5 OPL microprocessor controller (computer) will proceed into the Anti-Wrinkle Program. If the main door is not opened within the Anti-Wrinkle Delay Time (i.e., 90-seconds), the basket (tumbler) will rotate (without heat) for the programmed Anti-Wrinkle On Time (i.e., 20-seconds). The Phase 5 OPL microprocessor controller (computer) will repeat this process until the programmed Maximum Anti-Wrinkle On Time has expired (i.e., 10 minutes) or until the main door is opened, whichever comes first. The L.E.D. display will continue to read “donE,” until either the main door is opened or the Maximum Anti-Wrinkle On Time has expired, at which time the L.E.D. display will read “FILL” (no cycle in progress).



## 2. Manually Loaded Cycles

### a. Automatic Drying Cycle (**Patent No. 4,827,627**)

- 1) L.E.D. (light emitting diode) display reads “FILL” (no cycle in progress).
- 2) Press Key “2.”
- 3) L.E.D. display will now read “F,” meaning select Fabric (temperature) desired. Enter the temperature desired (from 160° F to 200° F [71° C to 93° C] in one-degree increments). For example, for F190, press key “1,” key “9,” key “0,” and then press the “ENTER/START” key.
- 4) L.E.D. display will now read “drY--LEuL,” for 1-second each and then the “percentage of dryness” 100 percent (100%). At this point the “percentage of dryness” can be changed (from 90% to 100% in one percent [1%] increments). For example, for 95%, press key “9,” key “5,” and then press the “ENTER/START” key.
- 5) For *optional reversing models*, if the system parameters are set for Select Reverse, the L.E.D. (light emitting diode) display will now read “Sr” meaning “Select Reverse.” If reversing basket (tumbler) action is desired, press the “ENTER/START” key. If No Reverse is desired, press the “0” key.
- 6) The dryer will now start and the L.E.D. display will show Cycle In Progress and Cycle Status (i.e., “dr00”), meaning that the dryer is in the Drying Cycle (Mode). During the Drying Cycle the Phase 5 OPL microprocessor controller (computer) is monitoring the moisture in the load. Approximately half way through the drying cycle, the Cycle Status portion of the L.E.D. will change from “00” to the percentage of extraction it senses (i.e., 68). The Cycle Status of the display will change and count upward until the percentage of extraction (i.e., 95%) is reached.

**NOTE:** To stop the dryer at any time, open the main door. To continue the cycle, close the main door and press the “PRESS START” key. The dryer will continue from where it left off...or the dryer may also be stopped by pressing the “CLEAR/STOP” key. However, the cycle that was in progress **will be cancelled**, and the L.E.D. (light emitting diode) display will return to the “FILL” (no cycle in progress) Mode.

- 7) Once the preprogrammed percentage of extraction (dryness level) is reached (i.e., 95%), the drying cycle will end, and the Cycle In Progress portion of the L.E.D. (light emitting diode) display will read “CL,” meaning that the dryer is now in the Cool Down Cycle (Mode). The Cycle Status portion of the L.E.D. display will continue to show the percentage of extraction. However, it serves no purpose in the Cool Down Cycle (Mode).
- 8) Once the Cool Down Cycle is completed, the dryer will shut off, the tone (buzzer) will sound (i.e., 7-seconds), and the L.E.D. display will read “donE.” The L.E.D. display will continue to read “donE” until the main door is opened.

- 9) If the Anti-Wrinkle Program is active (on), once the Drying Cycle and Cooling Cycles are completed and the L.E.D. (light emitting diode) display reads “donE” the Phase 5 OPL microprocessor controller (computer) will proceed into the Anti-Wrinkle Program (Mode). If the main door is not open within the Anti-Wrinkle Delay Time (i.e., 90-seconds), the basket (tumbler) will rotate (without heat) for the programmed Anti-Wrinkle On Time (i.e., 20-seconds). The Phase 5 OPL microprocessor controller (computer) will repeat this process until the programmed Maximum Anti-Wrinkle On Time has expired (i.e., 10 minutes) or until the main door is opened, whichever comes first. The L.E.D. display will continue to read “donE” until either the main door is opened or the Maximum Anti-Wrinkle On Time has expired, at which time the L.E.D. display will read “FILL” (no cycle in progress).

b. Timed (Manual) Dryer Cycle

- 1) L.E.D. display reads “FILL” (no cycle in progress).
- 2) Press key “5.”
- 3) L.E.D. display will now read “drY” for 1-second, “tInE” for 1-second, and then “00.” Enter the drying time desired (from 0 to 99 minutes in one [1] minute increments). For example, for 40 minutes, press key “4,” key “0,” and then press the “ENTER/START” key.
- 4) L.E.D. display will now read “Cool” for 1-second, “tInE” for 1-second, and then “00.” For example, for 10 minutes, press key “1,” key “0,” and then press the “ENTER/START” key.
- 5) L.E.D. display will now read “drY” for 1-second, “tEnP” for 1-second, and then “F,” meaning select Fabric (temperature) desired. Enter the temperature desired (from 100° F to 200° F [37° C to 93° C] in one-degree increments). For example, for 182° F (83° C), press key “1,” key “8,” key “2,” and then press the “ENTER/START” key.
- 6) For *optional reversing models*, if the system parameters are set for Select Reverse, the L.E.D. (light emitting diode) display will now read “Sr” meaning “Select Reverse.” If reversing basket (tumbler) action is desired, press the “ENTER/START” key. If No Reverse is desired, press the “0” key.
- 7) The dryer will now start, and the L.E.D. (light emitting diode) display will show Cycle In Progress and Cycle Status (i.e., “dr40”), meaning the dryer is in the Drying Cycle (Mode). During the Drying Cycle, the Cycle Status portion of the L.E.D. display will count downward in time until the drying time selection (i.e., 40 minutes) has expired.

**NOTE:** To stop the dryer at any time, open the main door. To continue the cycle, close the main door and press the “PRESS START” key. The dryer will continue from where it left off...or the dryer may also be stopped by pressing the “CLEAR/STOP” key. However, the cycle that was in progress **will be cancelled**, and the L.E.D. (light emitting diode) display will return to the “FILL” (no cycle in progress) Mode.

- 8) Once the programmed drying time has expired, the Phase 5 OPL microprocessor controller (computer) will proceed into the Cool Down Cycle (Mode) and the Cycle In Progress portion of the L.E.D. display will read “CL.” The Cycle Status portion of the L.E.D. display will read the programmed Cool Down Time (i.e., 10 minutes) and count downward until this time expires.

- 9) Once the Cool Down Cycle is completed, the dryer will shut off, the tone (buzzer) will sound (i.e., 7-seconds), and the L.E.D. (light emitting diode) display will read “donE.” The L.E.D. display will continue to read “donE” until the main door is opened.
- 10) If the Anti-Wrinkle Program is active (on), once the Drying Cycle and Cooling Cycle are completed and the L.E.D. (light emitting diode) display reads “donE” the Phase 5 OPL microprocessor controller (computer) will proceed into the Anti-Wrinkle Program (Mode). If the main door is not open within the Anti-Wrinkle Delay Time (i.e., 90-seconds), the basket (tumbler) will rotate (without heat) for the programmed Anti-Wrinkle On Time (i.e., 20-seconds). The Phase 5 OPL microprocessor controller (computer) will repeat this process until the programmed Maximum Anti-Wrinkle On Time has expired (i.e., 10 minutes) or until the main door is opened, whichever comes first. The L.E.D. display will read “donE” until either the main door is opened or the Maximum Anti-Wrinkle On Time has expired, at which time the L.E.D. display will read “FILL” (no cycle in progress).

## B. OPERATING NOTES

1. If the main door is opened while a cycle is in progress the L.E.D. (light emitting diode) display will read “door.” The L.E.D. display will continue to read “door” until the main door is closed. Once the main door is closed, the L.E.D. display will return to reading “dr\_\_.” The “ENTER/START” key **must now be** pressed to resume the drying cycle and cooling cycle.
2. If the system parameters are not programmed for Flash Display or Temperature Display the temperature in the basket (tumbler) can be read at the L.E.D. display while the cycle is in progress by pressing the “ENTER/START” key.
3. Preprogrammed Cycle “F” has been preprogrammed by the factory as a “Touch-Up Cycle” (unless otherwise specified at the time of ordering the dryer). This Touch-Up Cycle is programmed to operate in the Timed (Manual) Drying Cycle for 10 minutes of drying time at 170° F (77° C) and a 2 minute Cool Down.
  - a. Residing in Cycle “F” is the Special Cool Down Program/Selection (**Patent No. 5,161,314**)...
    - 1) This unique Cool Down Program/Selection is specifically designed to limit the amount of cooling that occurs during the Cool Down Cycle. During this Special Cool Down process, the Phase 5 OPL microprocessor controller (computer) cycles the heat at various intervals to achieve a gradual cool down of approximately 10° F (12° C) per minute.
4. A cycle in progress can be stopped and **cancelled** at any time by pressing the “CLEAR/STOP” key. The L.E.D. (light emitting diode) display will return to the “FILL” Mode (no cycle in progress).
5. When using the manual selection cycle, if an error is made making an entry, press the “CLEAR/STOP” key **ONCE**, and the entry **will be cancelled**. Re-enter the selection.

# SECTION V

## L.E.D. DISPLAY/CODES

The L.E.D. (light emitting diode) display informs the operator of cycle status, program verification, and displays important diagnostic codes and fault codes.

### A. L.E.D. DISPLAY OPERATING STATUS

#### 1. Cycles in Progress

- a. While the dryer is operating, the L.E.D. (light emitting diode) display will read which cycle is in progress. For example, in Drying Cycle (Mode), the L.E.D. display will read “dr” and in the Cool Down Cycle (Mode) the L.E.D. display will read “CL.”

#### 2. Cycle Status

- a. While a cycle is in progress, the L.E.D. display will show the progress of the cycle (load) that is being processed.
  - 1) Automatic Drying Cycle
    - a) Cycle Status portion of the display will change and count upward until the percentage of extraction.
  - 2) Timed (Manual) Drying Cycle
    - a) Cycle Status portion of the L.E.D. display will show the drying time or cooling time and will count upward until the programmed time has expired.

#### 3. Alternate Display Programs

- a. Programming allows for the L.E.D. (light emitting diode) display to read just the basket (tumbler) temperature or flash back and forth from Cycle In Progress or Basket (tumbler) Temperature while the dryer cycle is in progress. Unless otherwise specified at the time of ordering the dryer, the Phase 5 OPL microprocessor controller (computer) is programmed not to flash and to read the Cycle in Progress.

**NOTE:** Refer to the illustration on the following page (**page 25**) for details.

#### 4. Indicator Dots

- a. Located at the top of the L.E.D. (light emitting diode) display is a series of dots which indicate the various Phase 5 OPL microprocessor controller (computer) output functions while a cycle is in progress.
  - 1) Illustration No. 3 (refer to the following page [**page 25**]).
    - a) **ON INDICATOR** - this indicator dot is on whenever a cycle is in progress. Additionally, when the Anti-Wrinkle Program is active, this indicator dot will be on whenever the Phase 5 OPL microprocessor controller (computer) is in the Guard On Time Program.

- 2) Illustration No. 4 (refer to the illustration below)
  - a) **HEAT INDICATOR** -this indicator dot is on whenever the Phase 5 OPL microprocessor controller (computer) is calling for the heating unit to be active (on).
- 3) Illustration No. 5 (refer to the illustration below)
  - a) **REVERSING INDICATOR** - this indicator dot is functional for dryer models with the Reversing Action Option ONLY. This indicator dot will be on when the basket (tumbler) is in the reverse (counterclockwise [CCW]) direction.
- 4) Illustration No. 6 (refer to the illustration below)
  - a) **FORWARD INDICATOR** - this indicator dot is functional for dryer models with the Reversing Action Option ONLY. This indicator dot will be on when the basket (tumbler) is in the forward (clockwise [CW]) direction. Additionally, when the Anti-Wrinkle Program is active, this indicator dot will be on whenever the Phase 5 OPL microprocessor controller (computer) is in the Guard On Time Program (Mode).

## B. PHASE 5 OPL MICROPROCESSOR CONTROLLER (COMPUTER) L.E.D. DISPLAYS

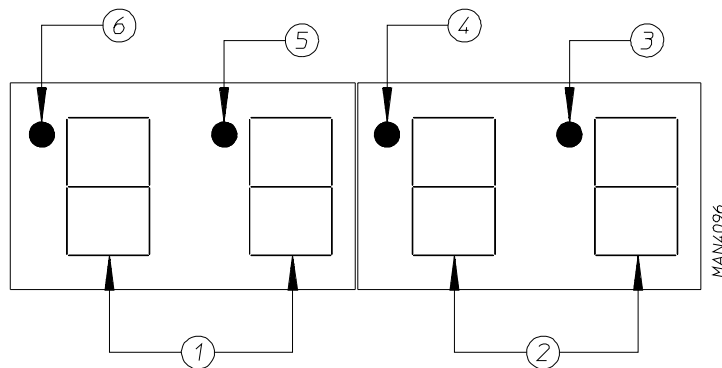

1. Cycle In Progress
  - a. dr --- Drying Time
  - b. CL -- Cool Down Time
2. Cycle Status
  - a. Automatic Mode Percent (%) of Extraction
  - b. Manual Mode displays Drying Time or Cool Down Time
3. On Indicator (dryer is in the Operating Mode)
4. Heat On Indicator
5. Basket (tumbler) in REVERSE MODE (counterclockwise [CCW]) Indicator
6. Basket (tumbler) in FORWARD MODE (clockwise [CW]) Indicator

## C. L.E.D. (LIGHT EMITTING DIODE) CODES

### 1. Display Codes

<b>A</b>	Slope Factor
<b>AUto</b>	Automatic Mode ( <b>Patent No. 4,827,627</b> )
<b>ArEu</b>	Always Reverse
<b>b</b>	Heat Loss (offset) Factor
<b>bUZ</b>	Buzzer (Tone)
<b>bUZ--tInE</b>	Buz Time
<b>°CEL</b>	Degrees in Celsius
<b>CL</b>	Cool Down Cycle In Progress
<b>Cool--tInE</b>	Cool Down Time
<b>Cool--tEnP</b>	Cool Down Temperature
<b>CY A</b>	Preprogrammed Cycle A
<b>CY b</b>	Preprogrammed Cycle b
<b>CY C</b>	Preprogrammed Cycle C
<b>CY d</b>	Preprogrammed Cycle d
<b>CY E</b>	Preprogrammed Cycle E
<b>CY F</b>	Preprogrammed Cycle F
<b>CYCL--tInE</b>	Cycle Display Time
<b>d</b>	Dryness Level (percentage of extraction) (Numerical Value)
<b>donE</b>	Drying or Cooling Cycles Complete or Dryer is in Anti-Wrinkle Mode
<b>door</b>	Door Circuit is Open or Fault in A.C. Door Switch Circuit
<b>dr</b>	Dryer Cycle is in Progress
<b>drY--LEuL</b>	Dryer Level (percentage of extraction)
<b>drY--tEnP</b>	Drying Temperature
<b>F</b>	Fabric (temperature)
<b>°FAr</b>	Degrees in Fahrenheit
<b>FILL</b>	No Cycle In Progress
<b>FLS</b>	Flash Display Active
<b>GdLY</b>	Anti-Wrinkle Delay Time
<b>G on--tInE</b>	Anti-Wrinkle On Time
<b>Grd</b>	Anti-Wrinkle Program Active
<b>Hot</b>	Overheating Condition
<b>MA nU</b>	Manual Mode
<b>MGrd</b>	Maximum Guard Time
<b>nbUZ</b>	No Buzzer (Tone)
<b>nGrd</b>	Anti-Wrinkle Program <u>Is Not</u> Active
<b>nrEu</b>	No Reverse
<b>nSC</b>	No Special Cool Down

<b>nSEn</b>	No Rotational Sensor Selected
<b>ProG</b>	Program Mode
<b>rEu</b>	Reverse
<b>SC</b>	Special Cool Down
<b>SEFL</b>	Rotational Sensor Circuit Failure
<b>SEn</b>	Rotational Sensor Selected
<b>SPIn--tInE</b>	Spin Time
<b>Sr</b>	Select Reverse
<b>SrEu</b>	Select Reverse
<b>StoP--tInE</b>	Stop Time
<b>tEnP--tInE</b>	Temperature Display Time
<b>tInE</b>	Time

## 2. Fault Codes

**door** -- Keyboard (touchpad) entry was made while the main door was open

or

Fault in the A.C. door switch circuit.

**dSFL** - Fault in the microprocessor temperature sensor circuit.

**SEFL** - Fault in the rotation of the basket (tumbler).

**Hot** --- Indicates that the dryer has experienced an overheating condition.

To cancel the “**Hot**” default code, press the “CLEAR/STOP” key.

# SECTION VI

## PROGRAMMING INSTRUCTIONS

### A. INTRODUCTION TO PROGRAMMING

The various program selections are stored in the Phase 5 OPL microprocessor controller (computer) and are broken down into two (2) categories:

1. Preprogrammed Cycles (key “A” through key “F”)
  - a. Allow the operator to have six (6) most commonly used cycle selections awaiting the push of a single keyboard (touchpad) entry to start the dryer.
2. System Parameters
  - a. Which are the programs set by the factory and rarely need to be changed in the field. These system parameters (programs) are stored in the memory as Program Locations (key “2,” key “5,” key “8,” and key “0”).

Both the preprogrammed cycles and the system parameters (programs) have been preprogrammed by the factory with the parameters shown on **page 54** and **page 55** of this manual. The various program selections for the preprogrammed cycles and system parameters are outlined in **Section III** of this manual.

**ALL** the program changes for the preprogrammed cycles and system parameters (programs) are done through the keyboard (touchpad) selection keys on the front of the control panel. To change programs, an access code **must be** entered. The procedure for entering this access code is as follows:

First, make sure that no cycle is in progress and that the L.E.D. (light emitting diode) display reads “FILL.” **Then press the “ENTER/START” key ONCE and the “0” key three (3) times. The “0” key must be pressed three (3) times within 2-seconds after pressing the “ENTER/START” key. If this access sequence is not entered correctly, the Phase 5 OPL microprocessor controller (computer) will deny access into the Program Mode.** If the access code is entered correctly, the L.E.D. display will read “ProG.” From this point, any of the preprogrammed cycles or system parameters (programs) can be accessed.

To alter the programming the operator will locate the parameter (program) that is to be changed. If the change is a numerical one (i.e., time and/or temperature), the operator will simply enter the numerical value desired. If an error is made, press the “CLEAR/STOP” key **ONCE**, and the incorrect entry that was made **will be cancelled**. Once the entry is made, or the parameter (program) set does not need to be changed, press the “ENTER/START” key, and the Phase 5 OPL microprocessor controller (computer) will advance to the next program selection.

When making numerical changes, please keep in mind to stay within the programming limits shown on **page 57** and **page 58**. If an erroneous entry is made, the Phase 5 OPL microprocessor controller (computer) will ignore the entry made when the “ENTER/START” key is pressed and will return to the numerical value previously set.



The Phase 5 OPL microprocessor controller (computer) walks the operator through the various parameters (programs) and advances each time the “ENTER/START” key is pressed. Once **ALL** the steps in the particular preprogrammed cycle or Program Location (system parameters) are set, the L.E.D. (light emitting diode) display will read “ProG.” At this point, the operator can go to the next preprogrammed cycle or Program Location (system parameter) to be changed. If no other programs (parameters) need to be changed, the user can get out of the program mode by pressing the “CLEAR/STOP” key. The Phase 5 OPL microprocessor controller (computer) will now return to the operating mode, and the L.E.D. (light emitting diode) display will read “FILL.”



## B. PROGRAMMING FLOWCHARTS

The following section of this manual (**page 29 through page 53**) explains the programming of the preprogrammed cycles and Program Locations (system parameters) through the use of flowcharts. A flowchart is nothing more than a diagram of the programming process.

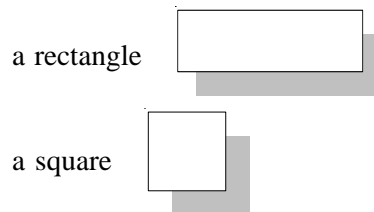
Two (2) different symbols will be used in these flowcharts:



Each rectangle will represent a read-out on the Phase 5 OPL microprocessor controller (computer) L.E.D. (light emitting diode) display, and each square will represent a key that is pressed. For example:

1. If the flowchart shows the symbol , the Phase 5 OPL microprocessor controller (computer) (computer) L.E.D. display will read the same.
2. If the flowchart shows the symbol  you will press that specific key on the keyboard (touch pad) label.
  - a. The flowchart arrows (i.e., ) represents the program path.
  - b. On the sides of these flowcharts are explanations of the flowchart procedure, and in some cases the programming limits.

Listed below, is an index of the flowcharts on the following pages.

## FLOWCHART TITLES

	<b>PAGE</b>
Entering and Exiting Program Mode .....	31
Programmed Cycles	
Automatic Drying Cycle ( <b>Patent No. 4,827,627</b> ) .....	32
Timed (Manual) Drying Cycle .....	36
System Parameters (Programs)	
Program Location 2 .....	40
Program Location 5 .....	42
Program Location 8 .....	44
Program Location 0 .....	47
Special Cool Down Program ( <b>Patent No. 5,161,314</b> ) .....	49
Manually Loaded Cycles	
Automatic Drying Cycle ( <b>Patent No. 4,827,627</b> ) .....	50
Timed (Manual) Drying Cycle .....	52

<p><b>NOTE:</b> To review the preset Program Locations, simply press key “8” when the L.E.D. (light emitting diode) displays “FILL.”</p>
--



# Preprogrammed Cycle Programming

Automatic Drying Cycle (Patent No. 4,827,627)

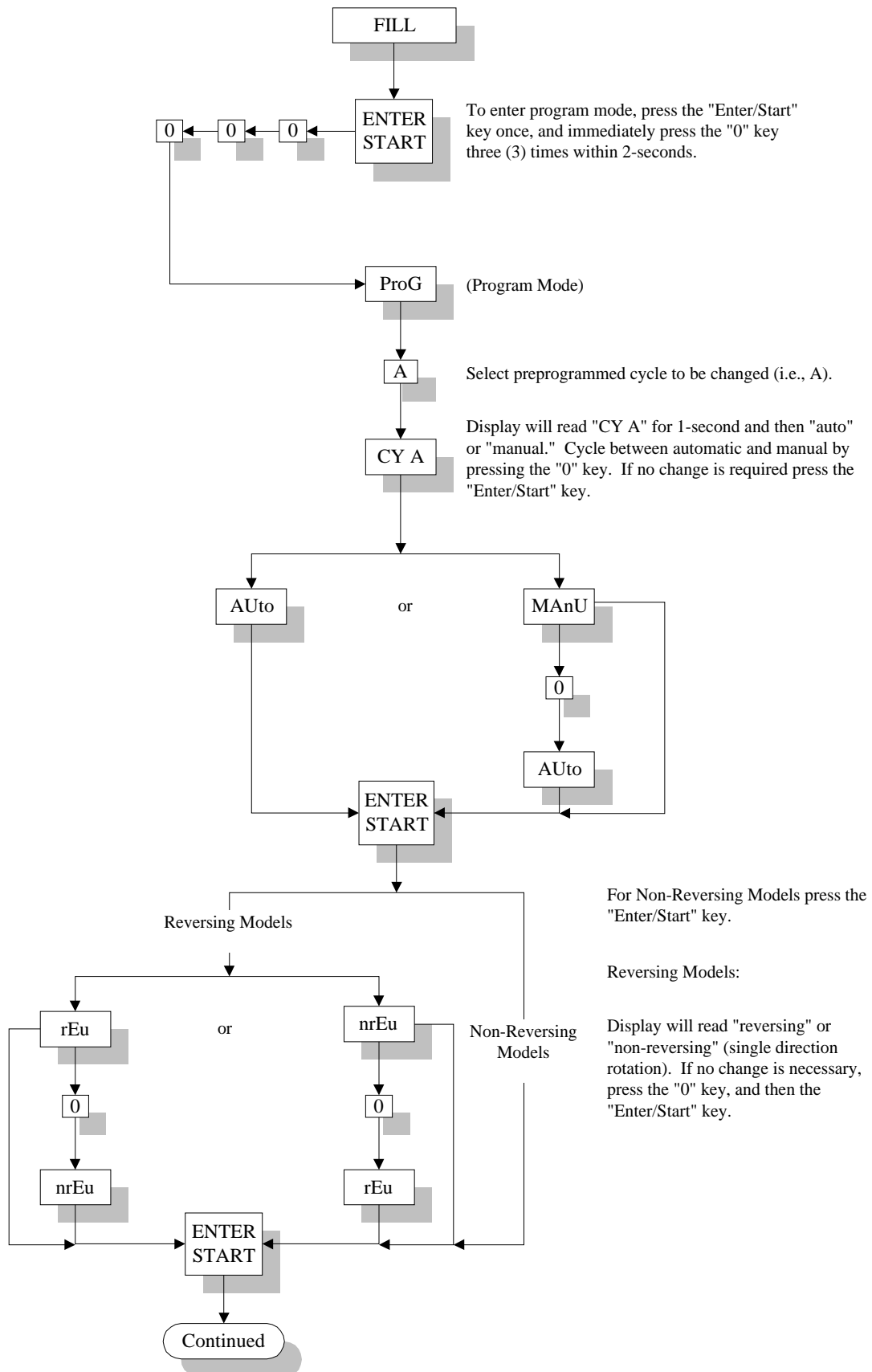

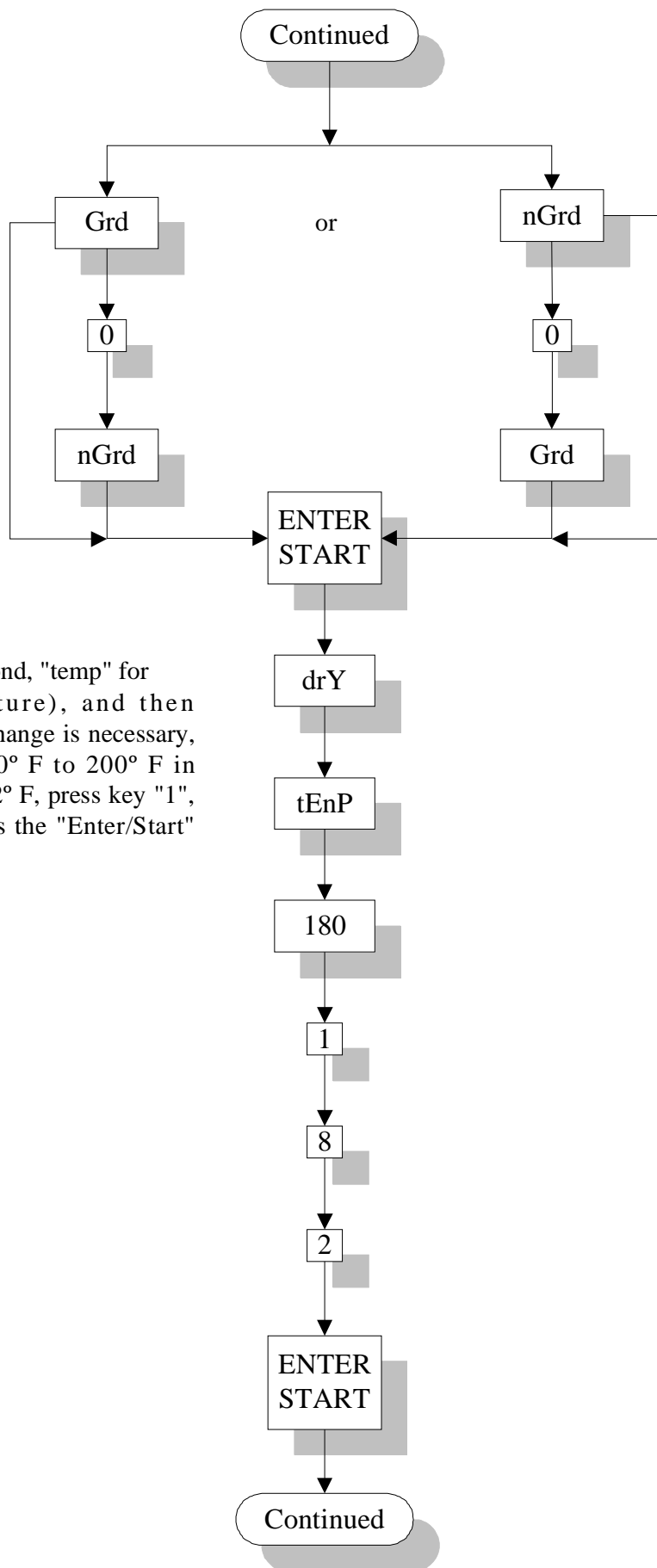

Display will read "dry" for 1-second, "temp" for 1-second (drying temperature), and then temperature programmed. If a change is necessary, enter temperature change (160° F to 200° F in increments of 1° F). I.E., for 182° F, press key "1", key "8", key "2", and then press the "Enter/Start" key.

Display reads "Dry" for 1-second.

Display reads "Level" for 1-second.

Dryness Level (% Extraction).

Press the "Enter/Start" key if no change is necessary. If a change is necessary, enter % change (90% to 100% in increments of 1%). I.E., for 95%, press key "0," key "9," key "5," and then press the "Enter/Start" key.

Display "Cool" for 1-second.

Display "Time" for 1-second.

Cool Down Time.

Press the "Enter/Start" key if no change is necessary. If a change is necessary, enter time change (0 to 99 minutes in increments of 1 minute). I.e., for 8 minutes, press key "0," key "8," and then press the "Enter/Start" key.

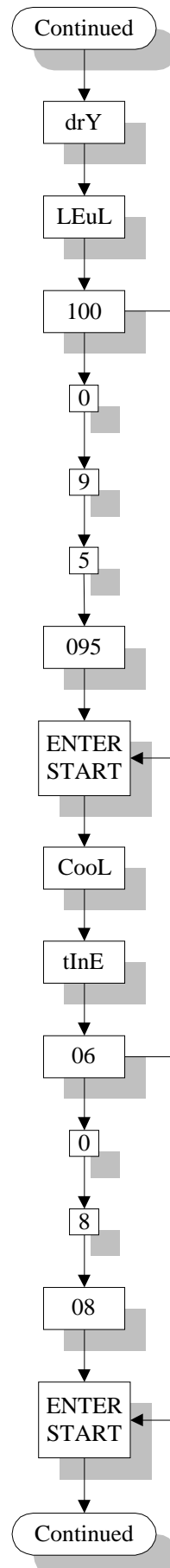

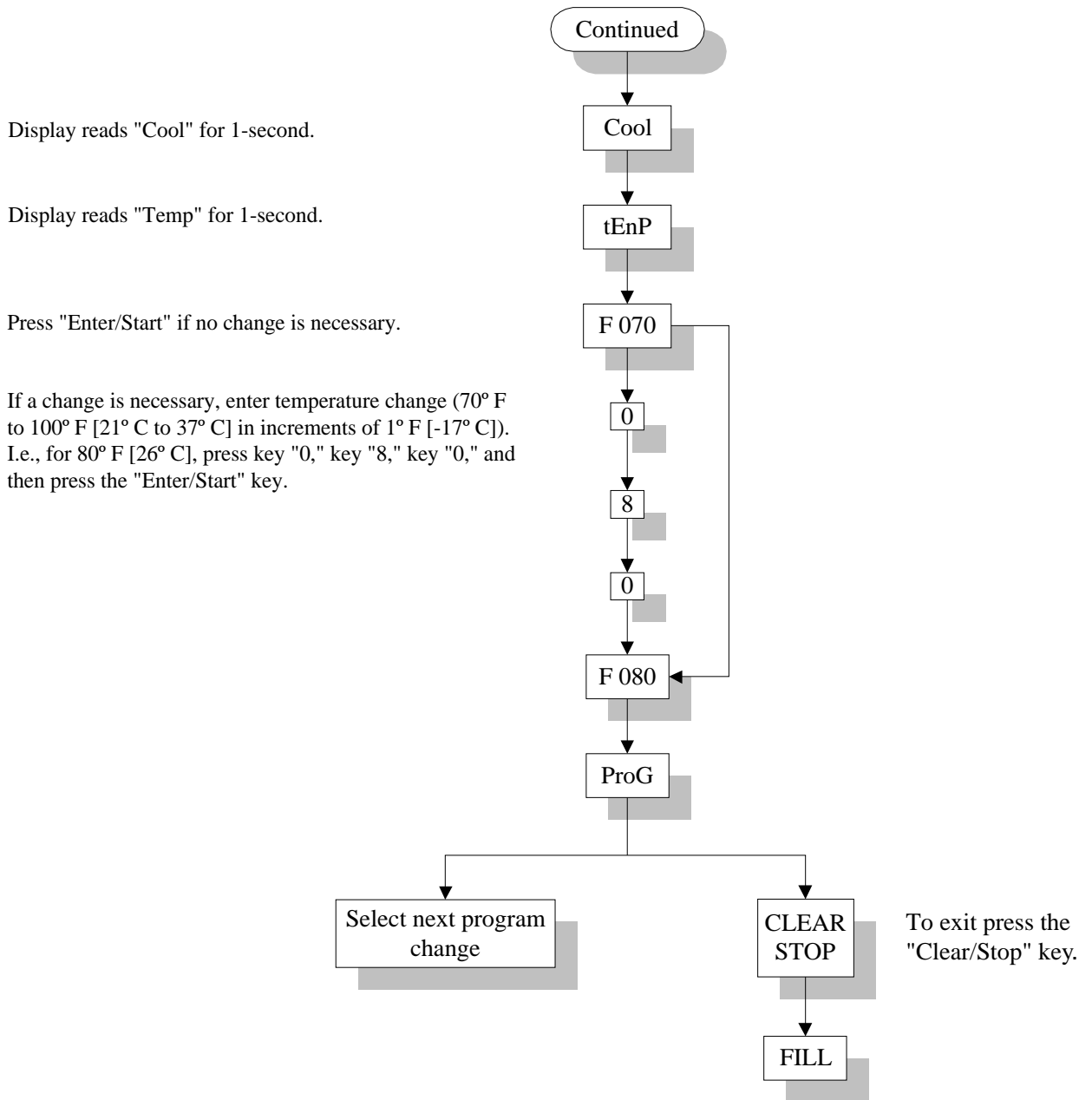

The cycle has now been entered and stored into the Phase 5 OPL Microprocessor Controller (computer) under key "A." By pressing key "A" when the display reads "FILL," this will begin the drying cycle.





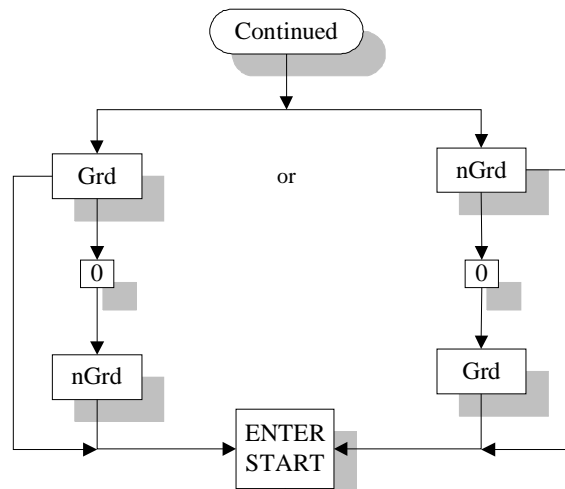

Display will read "dry" for 1 second, "time" for 1 second (drying temperature), and then drying time programmed. If no change is necessary, press the "Enter/Start" key. If a change is necessary, enter time change (10 to 99 minutes in increments of 1 minute. I.E., for 35 minutes", press key "0", key "3", key "5", and then press the "Enter/Start" key.

ENTER  
START

drY

tInE

40

0

3

5

ENTER  
START

Display will read "dry" for 1 second, "temp" for 1 second (drying temperature), and then temperature programmed. If a change is necessary, enter temperature change (100° F to 200° F in increments of 1° F). I.e., for 182° F, press key "1", key "8", key "2", and then press the "Enter/Start" key.

drY

tEnP

182

1

8

2

ENTER  
START

Continued

Display reads "Cool" for 1-second.

Display reads "Time" for 1-second.

Cool Down Time.

Press the "Enter/Start" key if no change is necessary. If a change is necessary, enter time change (0 to 99 minutes in increments of 1 minute). I.E., for 8 minutes, press key "0", key "8", and then press the "Enter/Start" key.

Display "Cool" for 1-second.

Display "Temp" for 1-second.

Cool Down Temperature.

Press the "Enter/Start" key if no change is necessary. If a change is necessary, enter temperature change (70° F to 100° F in increments of 1° F). I.E., for 80° F, press key "0", key "8", key "0", and then press the "Enter/Start" key.

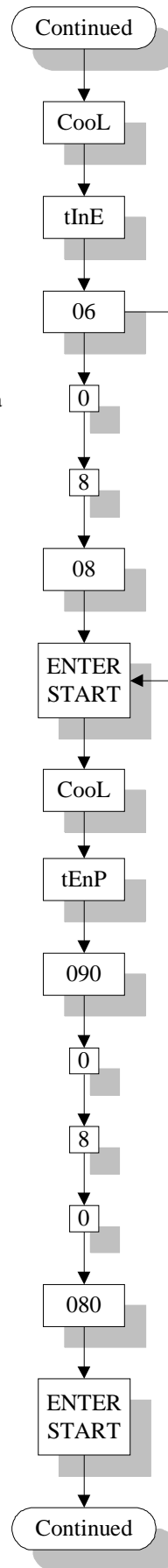

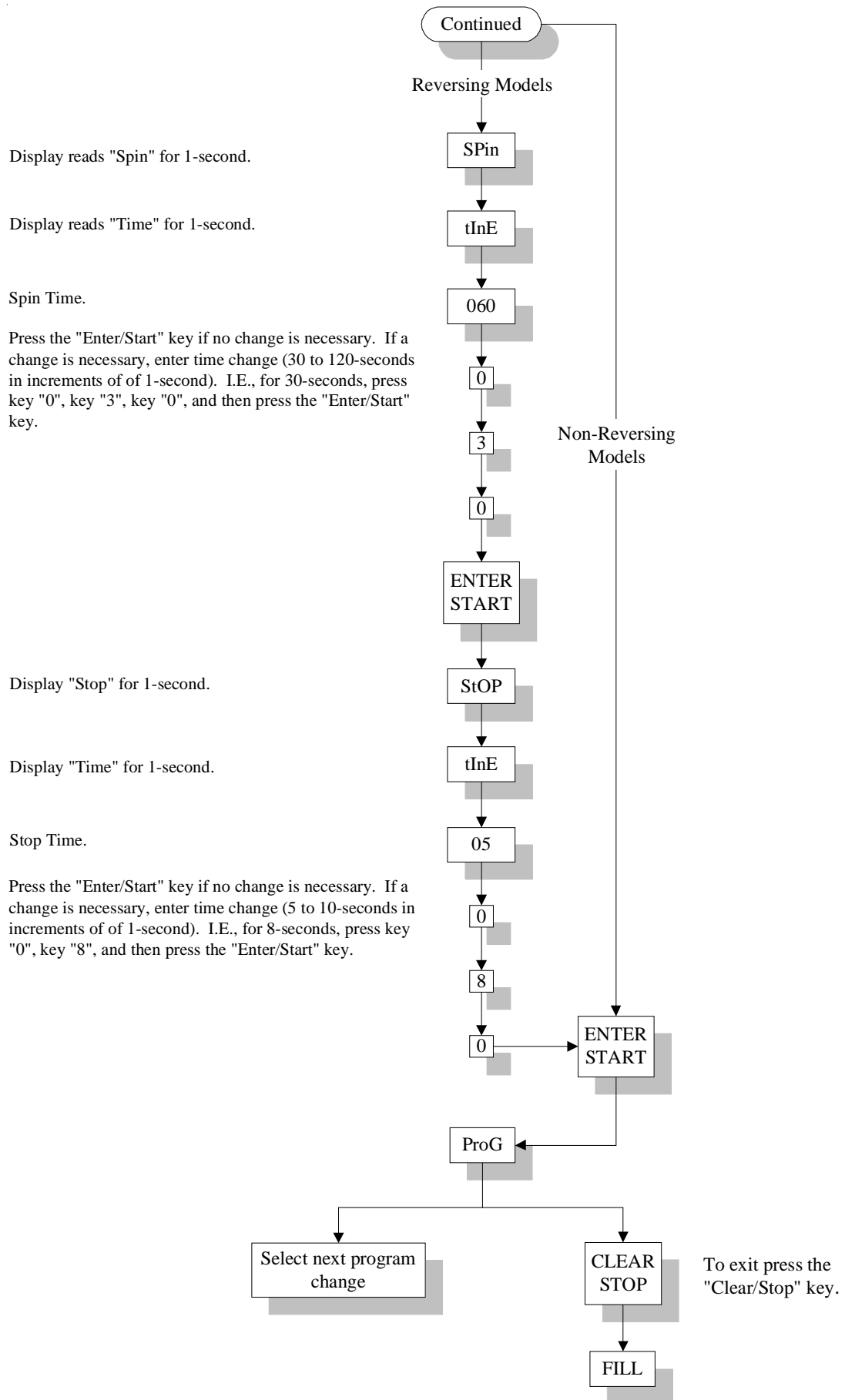

## Program Location 2

No Cycle In Progress

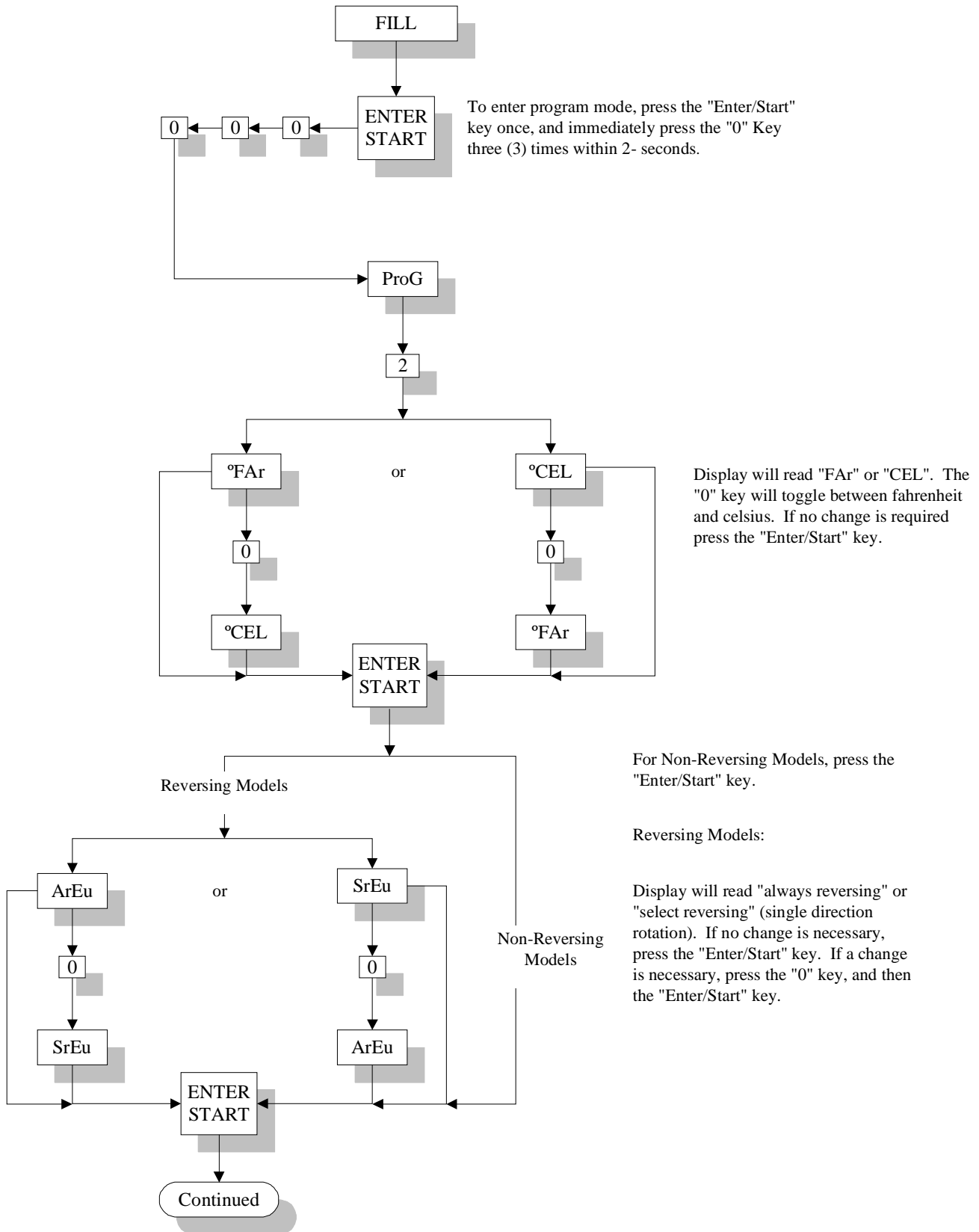

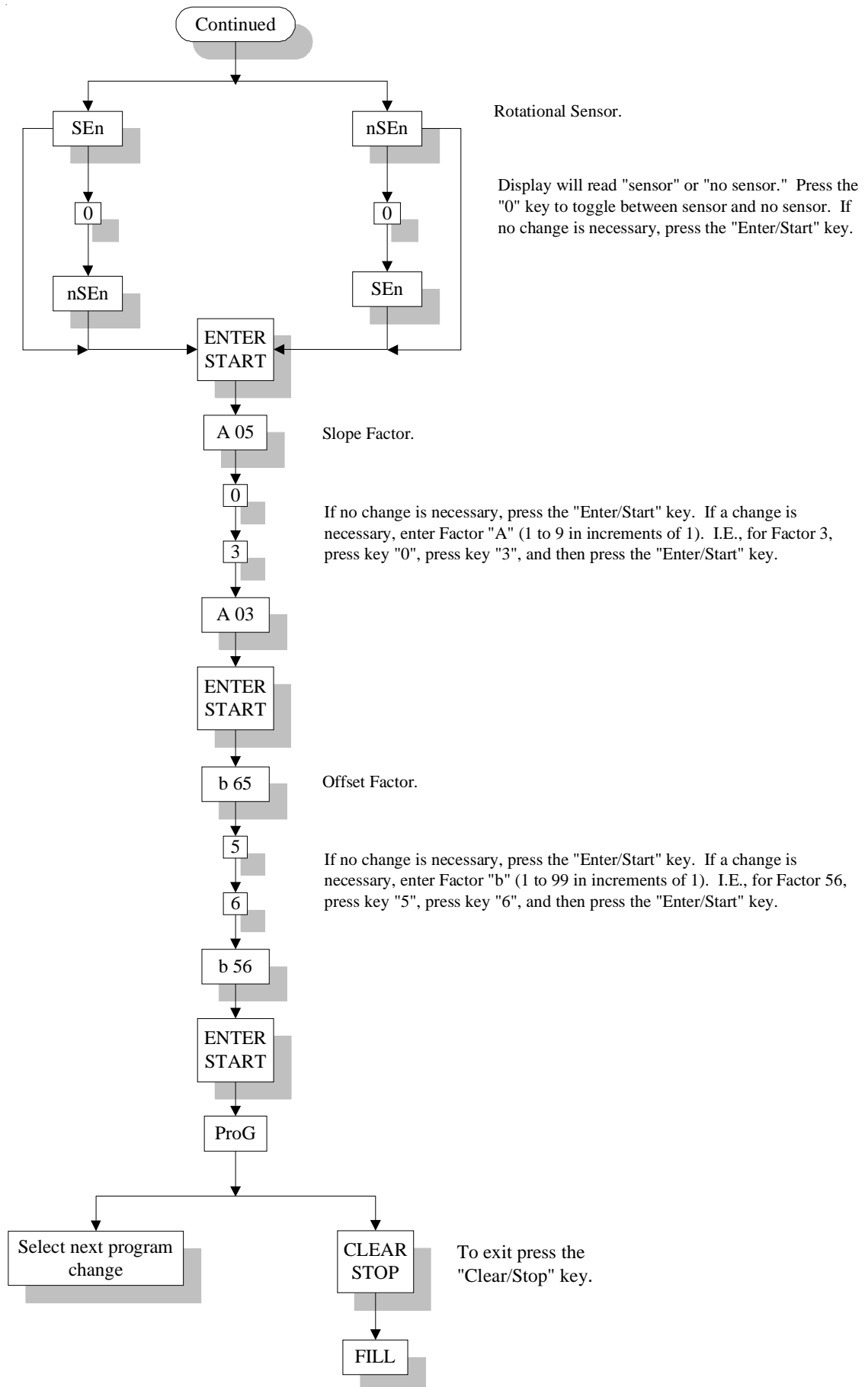

## Program Location 5

No Cycle In Progress

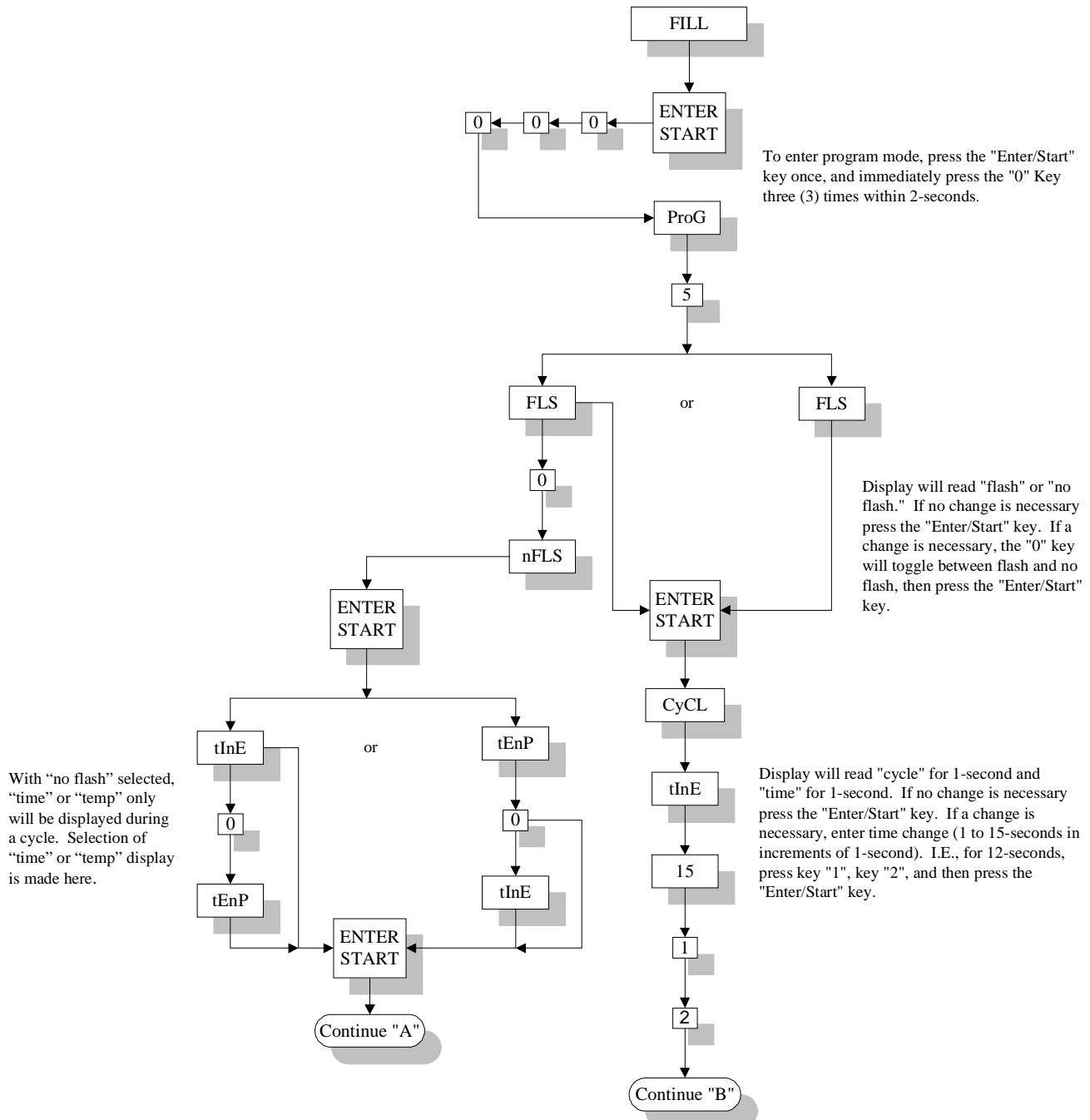

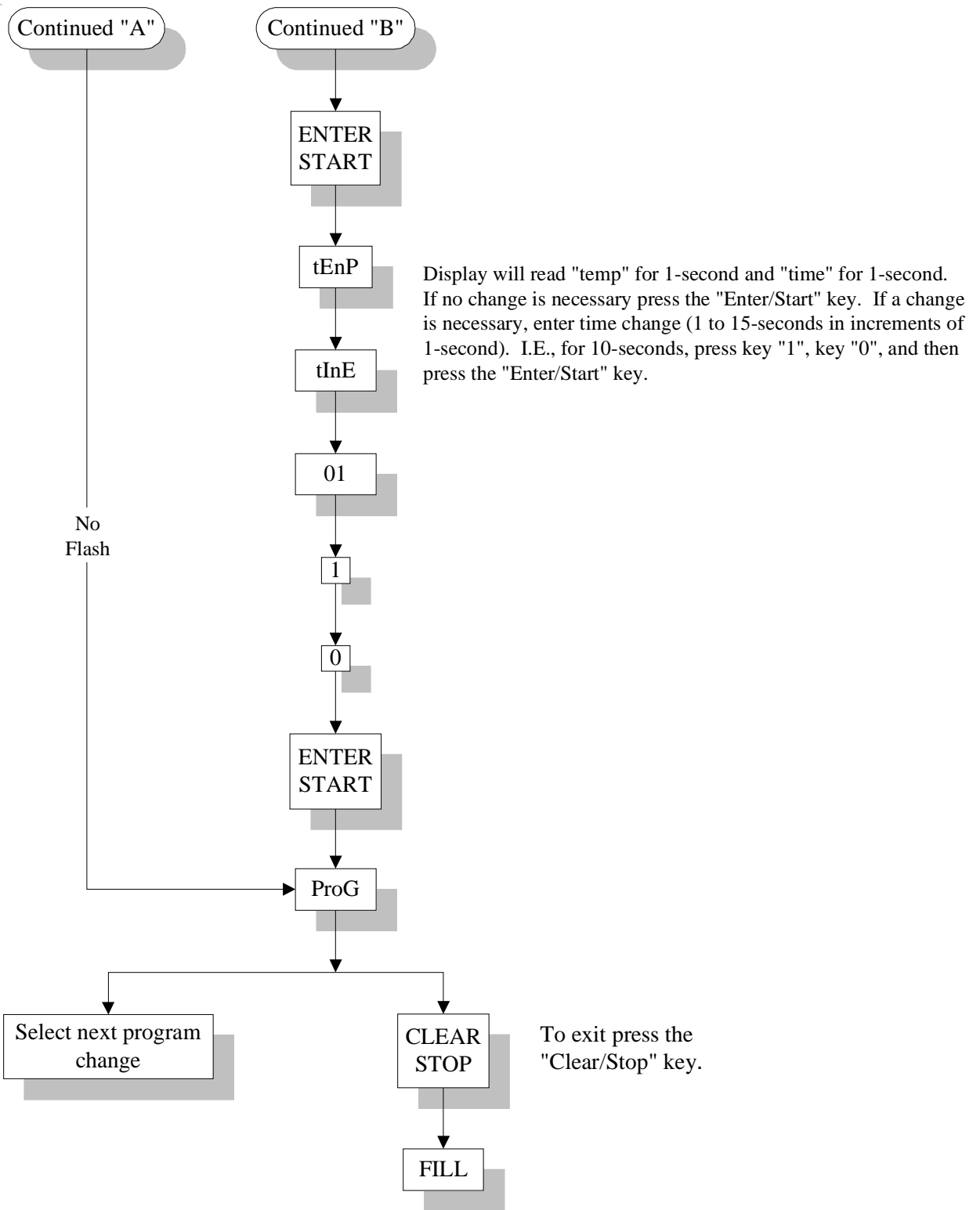

## Program Location 8

No Cycle In Progress

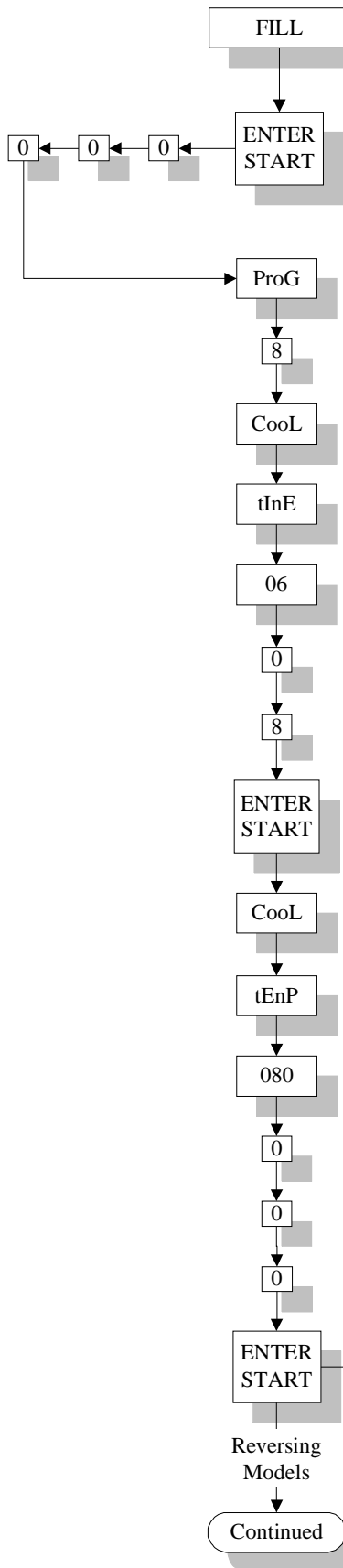

To enter program mode, press the "Enter/Start" key once, and immediately press the "0" Key three (3) times within 2-seconds.

Display will read "cool" for 1-second and "temp" for 1-second. If no change is necessary, press the "Enter/Start" key. If a change is necessary (0 to 99 minutes in increments of 1 minute). I.E., for 8 minutes, press key "0", key "8", and then press the "Enter/Start" key.

Display will read "cool" for 1-second and "temp" for 1-second. If no change is necessary, press the "Enter/Start" key. If a change is necessary, enter temperature change (70° F to 100° F in increments of 1° F). I.E., for 90° F, press key "0", key "9", key "0", and then press the "Enter/Start" key.



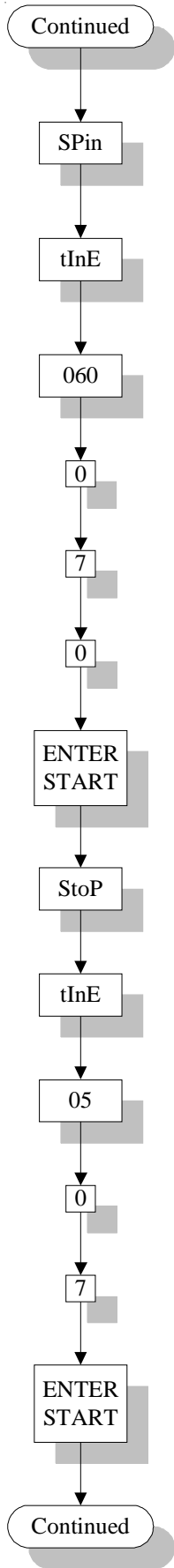

Display will read "stop" for 1-second and "time" for 1-second. If no change is necessary, press the "Enter/Start" key. If a change is necessary, enter time change (30 to 120-seconds in increments of 1-second). I.E., for 70-seconds, press key "0", key "7", key "0", and then press the "Enter/Start" key.

Display will read "stop" for 1-second and "time" for 1-second. If no change is necessary, press the "Enter/Start" key. If a change is necessary, enter time change (5 to 10-seconds in increments of 1-second). I.E., for 7 seconds, press key "0", key "7", and then press the "Enter/Start" key.

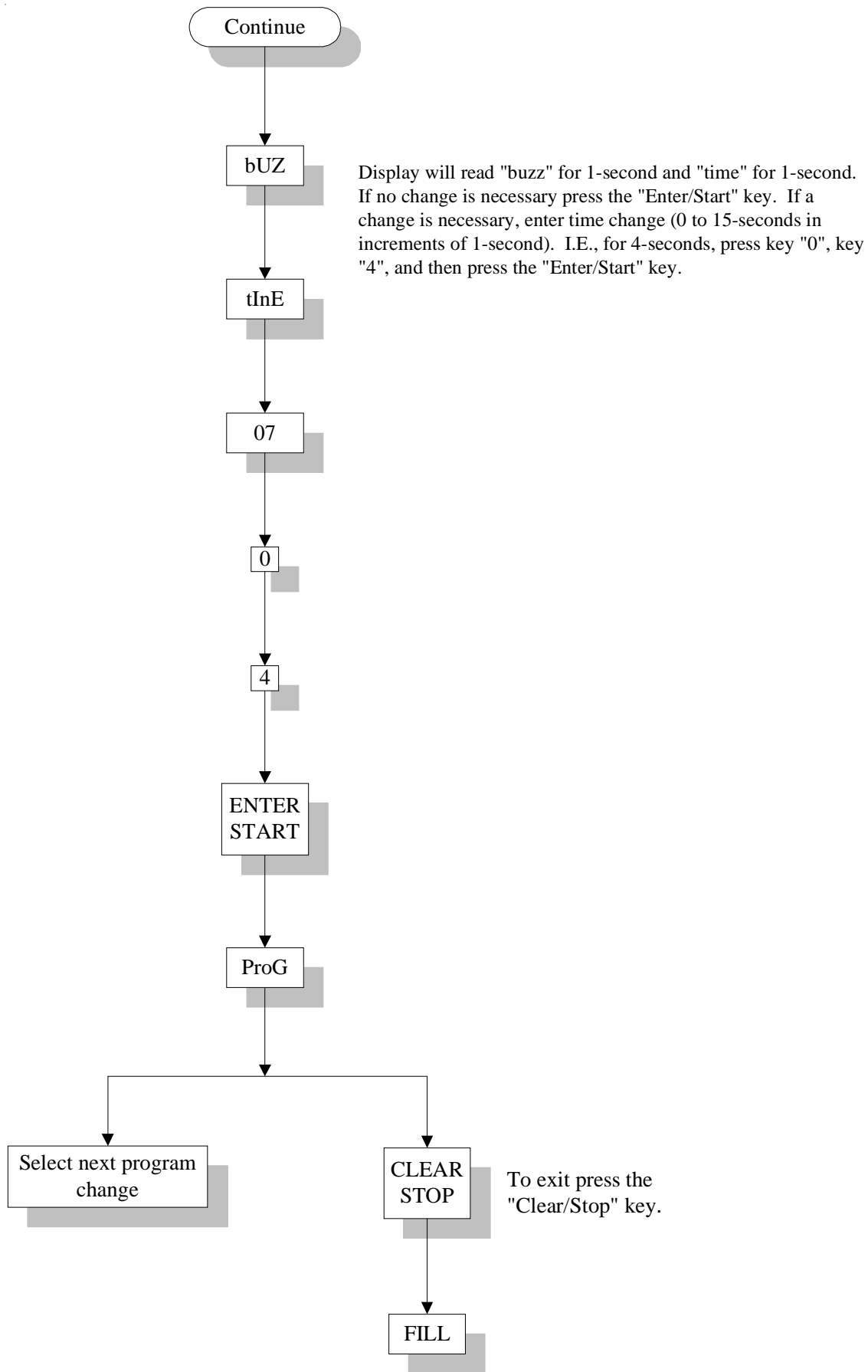

## Program Location 0

No Cycle In Progress

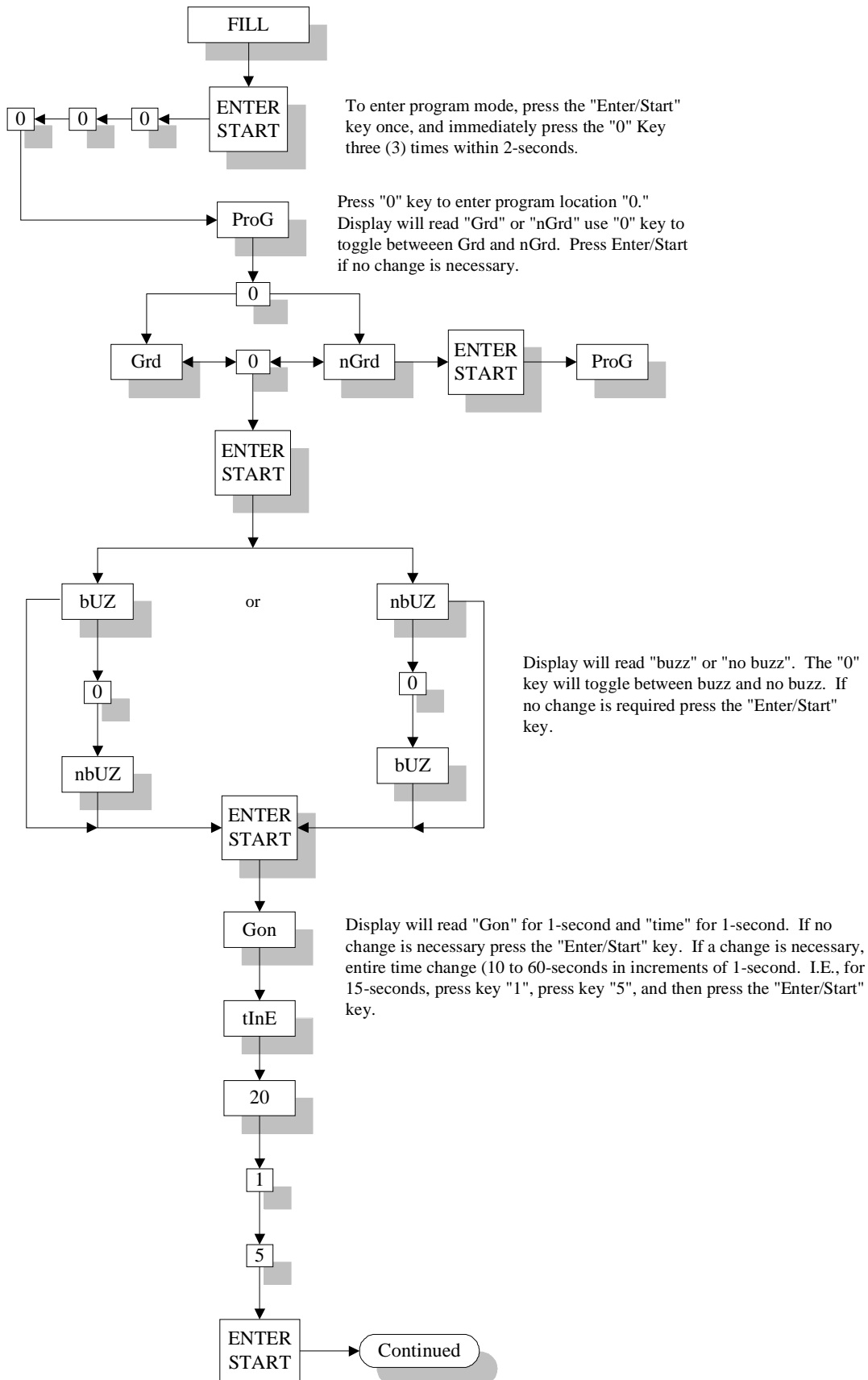

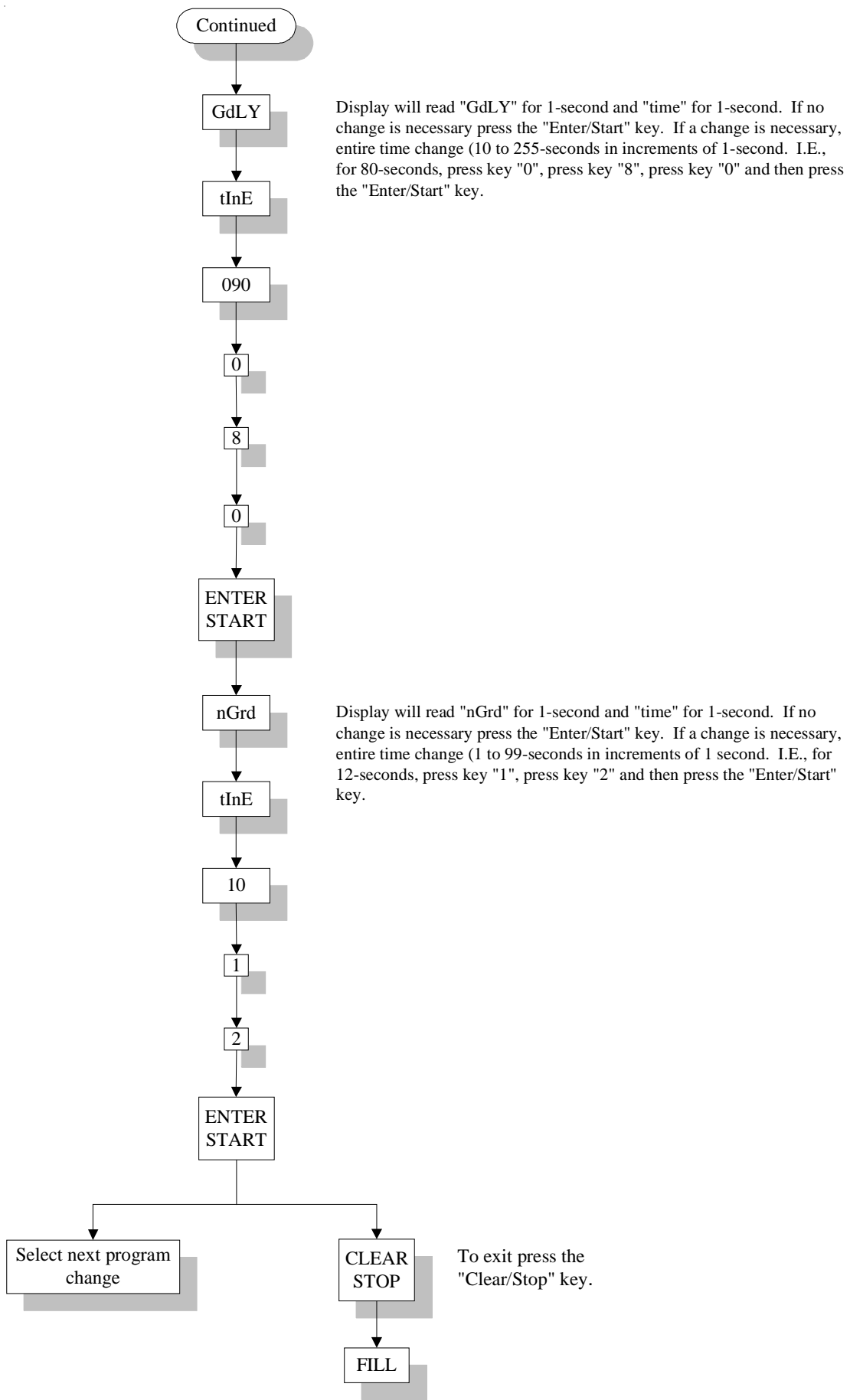

## Special Cool Down Program

This Special Cool Down Program is designed to limit the cooling process to 10° F per minute. This program was created to work well with fabrics that respond adversely to a great change in temperature (i.e., VISA®). THIS PROGRAM CAN ONLY BE FOUND IN PRESET CYCLE "F" WHEN THE PHASE 5 MICRO- PROCESSOR CONTROLLER (computer) HAS BEEN PROGRAMMED FOR SPECIAL COOL DOWN "SC".

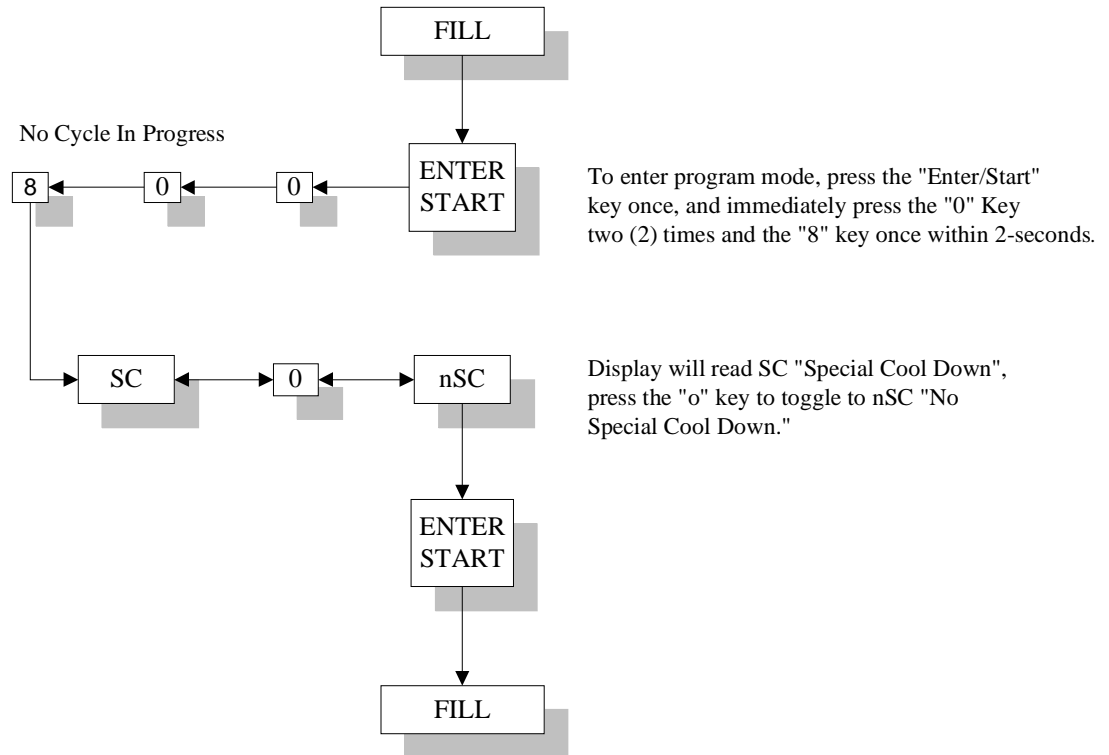

## Manually Loaded Cycle

Automatic Drying Cycle (Patent No. 4,827,627)

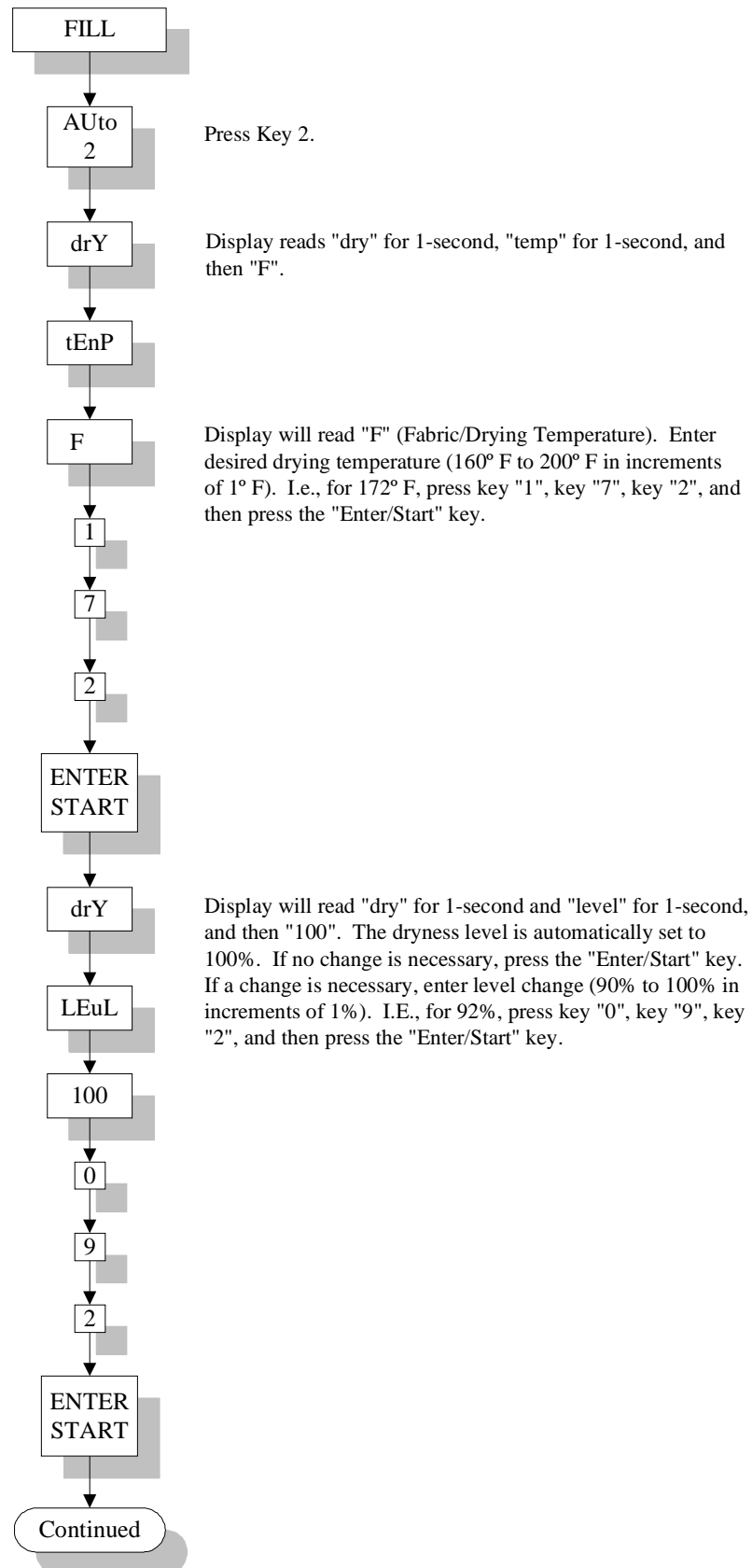

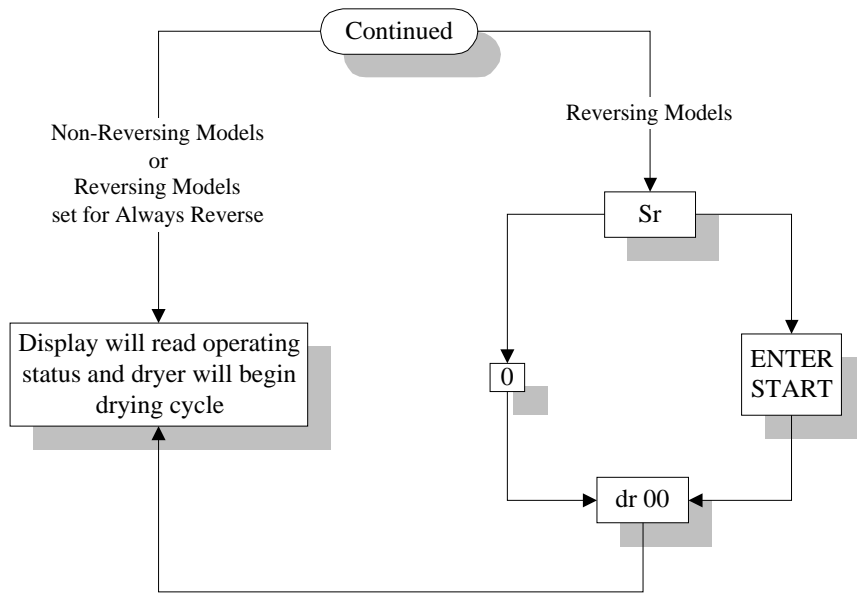

For Reversing Models.

Display will read "select reverse" if system parameter is programmed for select reverse. If reverse action is desired, press the "Enter/Start key. If no reverse action is desired, press the "0" key.

## Manually Loaded Cycle

Timed (Manual) Drying Cycle

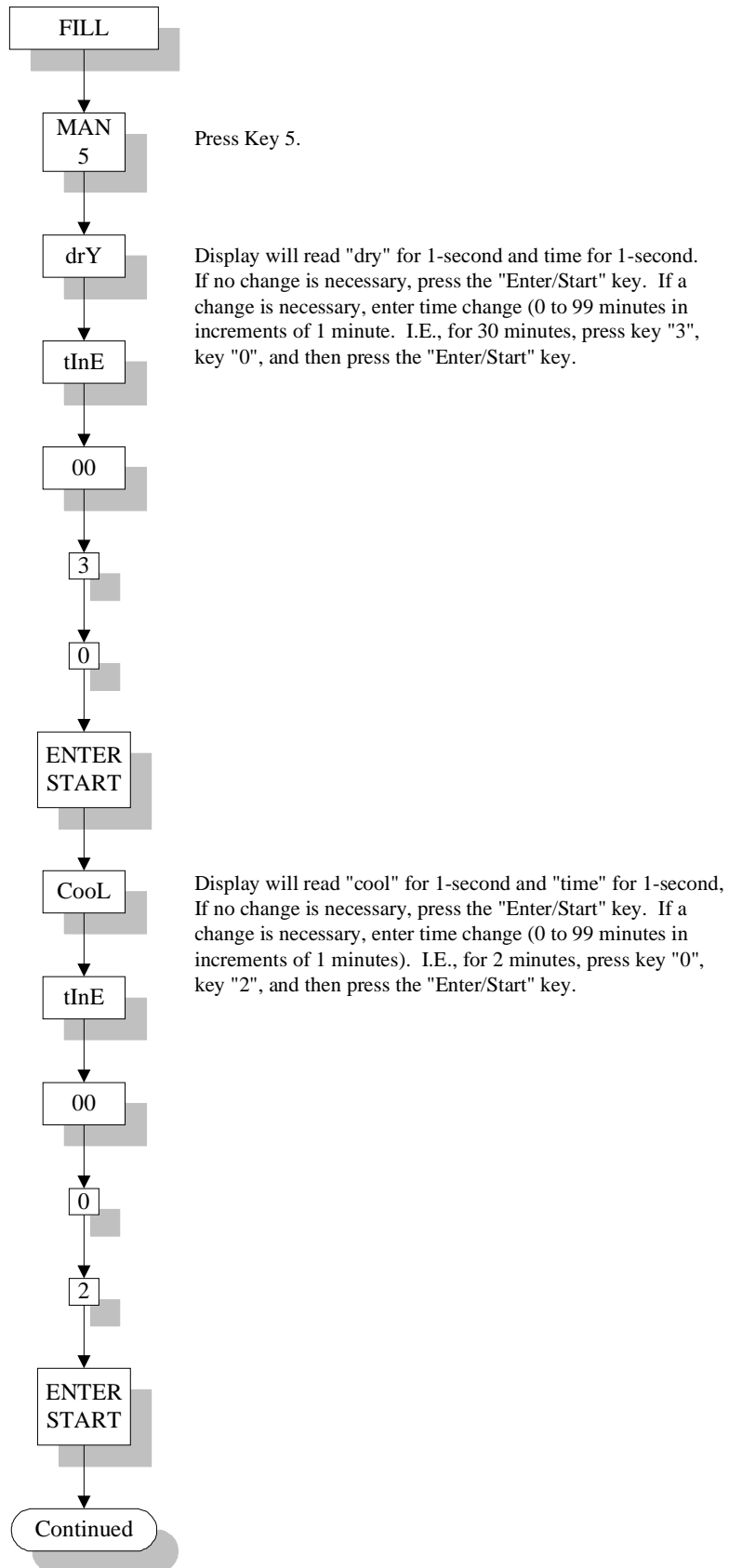



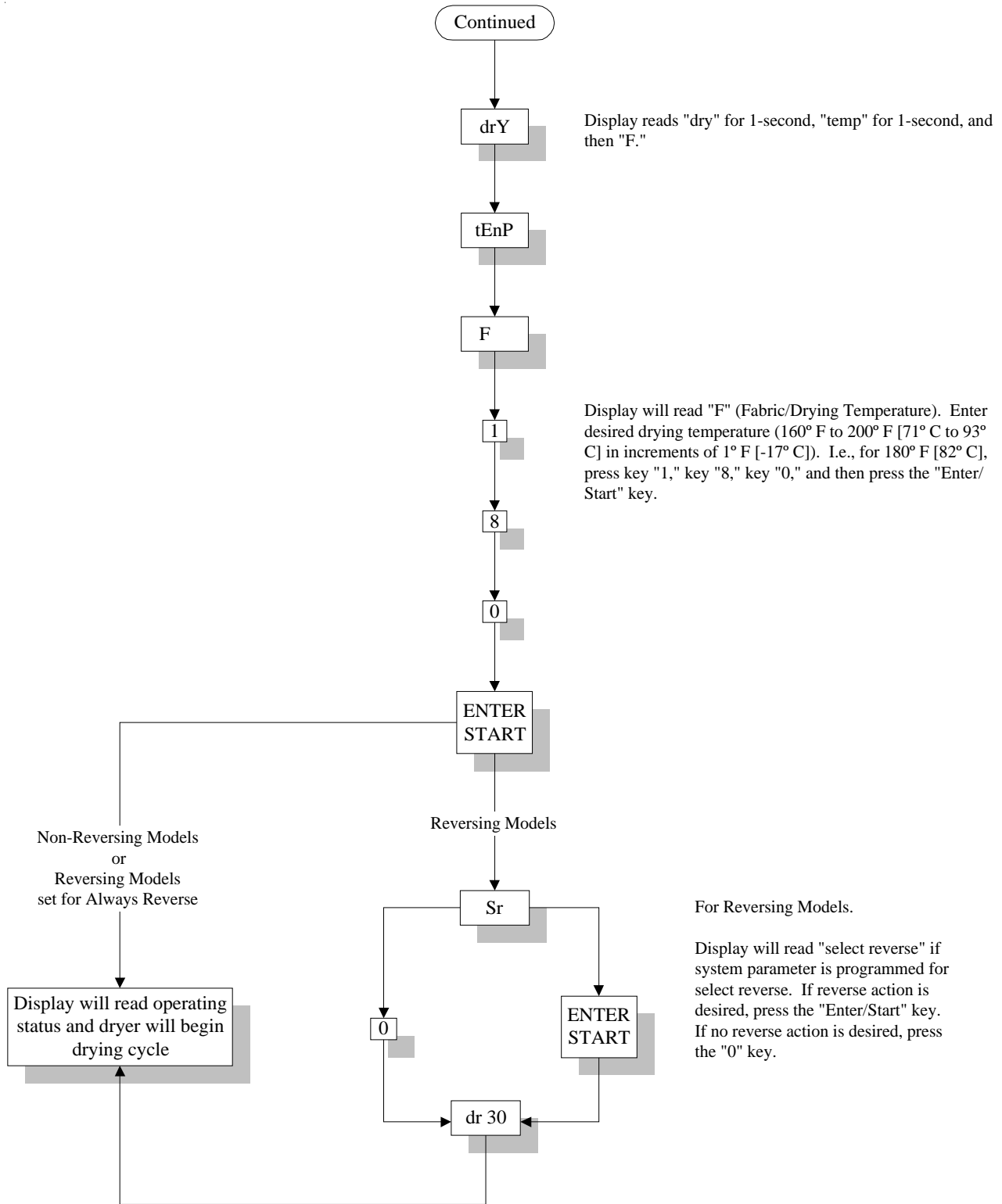

# SECTION VII

## FACTORY PRESET PARAMETERS/PROGRAMS

### A. PARAMETERS (PROGRAMS) PRESET BY FACTORY FOR NON-REVERSING DRYERS

#### **CYCLE A:**

Automatic Mode, Anti-Wrinkle Active, Dry Temperature 180° F (82° C), Dryness Level 100%, Cool Down Time 6 minutes, Cool Down Temperature 80° F (26° C).

#### **CYCLE B:**

Automatic Mode, Anti-Wrinkle Active, Dry Temperature 180° F (82° C), Dryness Level 98%, Cool Down Time 6 minutes, Cool Down Temperature 80° F (26° C).

#### **CYCLE C:**

Automatic Mode, Anti-Wrinkle Active, Dry Temperature 160° F (71° C), Dryness Level 98%, Cool Down Time 4 minutes, Cool Down Temperature 80° F (26° C).

#### **CYCLE D:**

Manual (Timed) Mode, Anti-Wrinkle Active, Dry Time 40 minutes, Dry Temperature 190° F (87° C), Cool Down Time 6 minutes, Cool Down Temperature 80° F (26° C).

#### **CYCLE E:**

Manual (Timed) Mode, Anti-Wrinkle Active, Dry Time 30 minutes, Dry Temperature 180° F (82° C), Cool Down Time 4 minutes, Cool Down Temperature 80° F (26° C).

#### **CYCLE F:**

Manual (Timed) Mode, Anti-Wrinkle Active, Dry Time 10 minutes, Dry Temperature 170° F (76° C), Cool Down Time 2 minutes, Cool Down Temperature 80° F (26° C).

### System Parameters/Programs

- Program Location 2 - (**Key “2”**) Temperature Conversion Status (set in Fahrenheit), Rotational Sensor (non-active), Factor “A” and Factor “B” (set for your particular model dryer and **should not be** changed).
- Program Location 5 - (**Key “5”**) No Flash Display, Display Time (Flash Cycle Display Time, 15-seconds, Flash Temperature Display Time 1-second).
- Program Location 8 - (**Key “8”**) Manual (Timed) Mode - Automatic and Manual Cool Down Time 6 minutes, Automatic and Manual Cool Temperature 80° F (26° C), Buz (Tone) Time 7- seconds.
- Program Location 0 - (**Key “0”**) Manual Selection Anti-Wrinkle Active, Anti-Wrinkle Buz (Tone) Active, Anti-Wrinkle On Time 60-seconds, Anti-Wrinkle Delay Time 120-seconds, Maximum Anti-Wrinkle Time 99 minutes.

## B. PARAMETERS (Programs) PRESET BY FACTORY FOR (OPTIONAL) REVERSING DRYERS

### **CYCLE A:**

Automatic Mode, Reverse, Anti-Wrinkle Active, Dry Temperature 180° F (82° C), Dryness Level 100%, Cool Down Time 6 minutes, Cool Down Temperature 80° F (26° C).

### **CYCLE B:**

Automatic Mode, Reverse, Anti-Wrinkle Active, Dry Temperature 180° F (82° C), Dryness Level 98%, Cool Down Time 6 minutes, Cool Down Temperature 80° F (26° C).

### **CYCLE C:**

Automatic Mode, Reverse, Anti-Wrinkle Active, Dry Temperature 160° F (71° C), Dryness Level 98%, Cool Down Time 4 minutes, Cool Down Temperature 80° F (26° C).

### **CYCLE D:**

Manual (Timed) Mode, Reverse, Anti-Wrinkle Active, Dry Time 40 minutes, Dry Temperature 190° F (87° C). Cool Down Time 6 minutes, Cool Down Temperature 80° F (26° C), Spin Time 60-seconds, Dwell (Stop) Time 5-seconds.

### **CYCLE E:**

Manual (Timed) Mode, Reverse, Anti-Wrinkle Active, Dry Time 30 minutes, Dry Temperature 180° F (82° C), Cool Down Time 4 minutes, Cool Down Temperature 80° F (26° C), Spin Time 60-seconds, Dwell (Stop) Time 5-seconds.

### **CYCLE F:**

Manual (Timed) Mode, Reverse, Anti-Wrinkle Active, Dry Time 10 minutes, Dry Temperature 170° F (76° C), Cool Down Time 2 minutes, Cool Down Temperature 80° F (26° C), Spin Time 60-seconds, Dwell (Stop) Time 5-seconds.

### System Parameters/Programs

- Program Location 2 - (**Key “2”**) Temperature Conversion Status (set in Fahrenheit), Rotational Sensor (non-active), Factor “A” and Factor “B” (set for your particular model dryer and **should not be** changed).
- Program Location 5 - (**Key “5”**) No Flash Display, Display Time (Flash Cycle Display Time, 15-seconds, Flash Temperature Display Time 1-second).
- Program Location 8 - (**Key “8”**) Manual (Timed) Mode - Automatic and Manual Cool Down Time 6 minutes, Automatic and Manual Cool Temperature 80° F (26° C), Manual Selection Spin Time 60-seconds, Manual Selection Dwell (Stop) Time 5-seconds, Buz (Tone) Time 7-seconds.
- Program Location 0 - (**Key “0”**) Manual Selection Anti-Wrinkle Active, Anti-Wrinkle Buz (Tone) Active, Anti-Wrinkle On Time 60-seconds, Anti-Wrinkle Delay Time 120-seconds, Maximum Anti-Wrinkle Time 99 minutes.

# SECTION VIII

## SYSTEM PARAMETER/PROGRAM LOCATION CHART

<b>PHASE 5 OPL PROGRAM LOCATIONS</b>	
LOCATIONS/PROGRAMS	CYCLES AFFECTED
<b>PROGRAM LOCATION 2 - KEY "2"</b>	
Display Temperature (°F or °C)	MLC and PPC
Select Reverse or Always Reverse*	MLC ONLY
Rotational Sensor or No Rotational Sensor	MLC and PPC
"A" Factor (SLOPE)	MLC and PPC
Refer to charts on <b>page 59</b> and <b>page 60</b>	
"B" Factor (SLOPE)	MLC and PPC
Refer to charts on <b>page 59</b> and <b>page 60</b>	
<b>PROGRAM LOCATION 5 - KEY "5"</b>	
Flash or No Flash	MLC and PPC
Time or Temperature Display (NO FLASH ONLY)	MLC and PPC
Flash Cycle Display Time	MLC and PPC
Flash Temperature Display Time	MLC and PPC
<b>PROGRAM LOCATION 8 - KEY "8"</b>	
Cool Down Time	MLC ONLY
Cool Down Temperature	MLC ONLY
Spin Time (All Except Timed Dry PPC)	MLC ONLY
Stop (DWELL) Time (All Except Timed Dry PPC)	MLC ONLY
End-Of-Cycle Buz (TONE) Time	MLC and PPC
<b>PROGRAM LOCATION 0 - KEY "0"</b>	
With or Without Anti-Wrinkle	MLC ONLY
Anti-Wrinkle Buz (TONE) On or Off	MLC and PPC
Anti-Wrinkle On Time	MLC and PPC
Anti-Wrinkle Delay Time	MLC and PPC
Maximum Anti-Wrinkle Time	MLC and PPC

MLC - MANUALLY LOADED CYCLES

PPC - PREPROGRAMMED CYCLES

\* Reversing Models ONLY.

# SECTION IX

## PHASE 5 OPL PROGRAMMING LIMITS

### A. PREPROGRAMMED CYCLES

#### 1. Automatic Cycle/Mode (Patent No. 4,827,627)

- a. Drying Temperature (“**drY tEnP**”) from 160° F to 200° F (71° C to 93° C) in one-degree increments.
- b. Dryness Level (percentage of dryness [“**drY LEuL**”]) from 90% to 100% in one percent (1%) increments.
- c. Cool Down Time (“**Cool tInE**”) from 0 to 99 minutes in one minute increments.
- d. Cool Down Temperature (“**Cool tEnP**”) from 70° F to 100° F (21° C to 37° C) in one-degree increments.

#### 2. Timed (Manual) Drying Cycle (Mode)

- a. Drying Temperature (“**drY tEnP**”) from 100° F to 200° F (37° C to 93° C) in one-degree increments.
- b. Drying Time (“**drY tInE**”) from 0 to 99 minutes in one minute increments.
- c. Cool Down Time (“**Cool--tInE**”) from 0 to 99 minutes in one minute increments for preprogrammed cycle.
- d. Cool Down Temperature (“**Cool--tInP**”) from 70° F to 100° F (21° C to 37° C) in one-degree increments.
- e. Reversing Models

##### 1) Automatic Cycle/Mode (Patent No. 4,827,627)

IS NOT PROGRAMMABLE

##### 2) Timed Cycle

- a) Spin Time (“**SPIn--tInE**”) from 30-seconds to 120-seconds in one-second increments.
- b) Dwell (Stop) Time (“**StoP--tInE**”) from 5-seconds to 10-seconds in one-second increments.

### B. SYSTEM PARAMETERS (PROGRAM LOCATIONS)

1. **Factor “A”** (Slope) from 1 to 9 in increments of one (1).
2. **Factor “B”** (Heat Loss - Offset) from 1 to 99 in increments of one (1).
3. Manual Selection Auto Mode Cool Down Time from 0 to 15 minutes in 1 minute increments.
4. Maximum Guard Time (“**MGrd**”) from 1 minute to 99 minutes in 1 minute increments.

5. Guard On Time (“**G on--tInE**”) from 10 to 60-seconds in one-second increments.
6. Guard Delay Time (“**GdLY**”) from 10 to 255-seconds in one-second increments.
7. Buzz (Tone) Time (“**bUZ--tInE**”) from 0 to 15-seconds in one-second increments.
8. Flash Display Cycle/Time (“**FLS**”) 1 to 15-seconds in one-second increments.
9. Flash Display Temperature/Time 1 to 15-seconds in one-second increments.

### C. FIXED PARAMETERS

1. Spin Time (“**SPIn--tInE**”) is fixed at 2 minutes (in the Automatic Cycle/Mode [**Patent No. 4,827,627**])

#### IS NOT PROGRAMMABLE

- a. Timed Cycle - 30-seconds to 120-seconds in one-second increments.

2. Dwell (Stop) Time (“**StoP--tInE**”) is fixed at 5-seconds (in the Automatic Cycle/Mode [**Patent No. 4,827,627**])

#### IS NOT ADJUSTABLE

- a. Timed Cycle - 5-seconds to 10-seconds in one-second increments.

# SECTION X

## PHASE 5 AUTO CYCLE (Patent No. 4,827,627)

### “A” AND “B” FACTOR PARAMETERS for *Current Production Dryer Models*

GAS		
MODEL	"A"	"B"
ADG-15D	3	80
ADG-24D	5	65
ADS-25D	5	80
ADG-26D	N/A*	
ADG-27D	N/A*	
ADG-235	5	65
ADG-285DH	5	65
ADG-295	N/A*	
ADG-320D	5	75
ADG-330D	5	75
ADG-385D	N/A*	
ADG-430D	5	75
ADG-530HS	N/A*	
ADG-630D	5	75
ADG-30DS (A)	5	70
ADG-30DS (B)	N/A*	
ADG-30D	5	70
ADG-50DS (A)	N/A*	
ADG-50DS (B)	N/A*	
ADG-50D	5	72
ADG-60D	5	65
ADG-75D	5	65
ADG-75T	5	73
ADG-81 (C)	5	72
ADG-115D (C)	5	70
ADG-120ES (C)	5	75
ADG-170SE (C)	5	70
ADG-200D (C)	5	78
ADG-310D (C)	N/A*	
ADG-410D (C)	5	65

ELECTRIC			
MODEL	KW	"A"	"B"
ADE-15	12	2	74
	15	2	55
	18	3	63
ADE-24	18	N/A*	
	20	N/A*	
	24	N/A*	
ADE-25	18	2	65
	20	3	80
	24	5	80
ADE-320	15	N/A*	
ADE-330	15	N/A*	
ADE-30S	30 (B)	N/A*	
	36 (A)	5	70
	40 (B)	N/A*	
	42 (A)	N/A*	
ADE-30	48 (A)	N/A*	
	20	3	80
	24	5	80
ADE-50S	30	5	75
	30 (B)	N/A*	
	36 (A)	N/A*	
ADE-50	40 (B)	N/A*	
	42 (A)	N/A*	
	48 (A)	N/A*	
	20	5	81
ADE-60	24	5	65
	30	5	75
	20	5	65
ADE-75	24	5	81
	30	5	72
	20	5	81
	24	5	81
ADE-115	36	5	76
	30	5	75
	60	5	60
ADE-120ES	72	5	80
	80	5	90

STEAM			
MODEL	TYPE	"A"	"B"
ADS-15	HIGH OR LOW	N/A*	
ADS-25		N/A*	
ADS-320		N/A*	
ADS-330		N/A*	
ADS-30S		N/A*	
ADS-50S		N/A*	
ADS-60S		N/A*	
ADS-75		N/A*	
ADS-81		5	65
ADS-115		5	68
ADS-120ES		5	65
ADS-170SE		N/A*	
ADS-200 (D)		5	78
ADS-200 (E)		5	72
ADS-310		N/A*	
ADS-410		5	65

\* “A” and “B” Factors not available at time of printing.

PHASE 5 “A” and “B” Factor Parameter Listing for *Past Production Models* are on the following page (page 60).

- (A) For **60 Hz** models *ONLY*.
- (B) For **50 Hz** models *ONLY*.
- (C) For non-Heat Reclaimer models *ONLY*.
- (D) For models manufactured with a **7.5 HP Blower** (impellor/fan) **Motor**.
- (E) For models manufactured with a **15 HP Blower** (impellor/fan) **Motor**.

**“A” AND “B” FACTOR PARAMETERS for Past Production Dryer Models**

<b>GAS</b>		
<b>MODEL</b>	<b>"A"</b>	<b>"B"</b>
ADG-215D	5	67
ADG-220D	5	65
ADS-230	5	65
ADG-530D	N/A*	
UDG-50D	5	65
ADG-80D (A)	5	67
ADG-80D (B)	5	77
UDG-80D (A)	5	67
UDG-80D (B)	5	77
ADG-575D	5	65
ADG-120D (C)	5	75
ADG-170D (C)	5	72

<b>ELECTRIC</b>			
<b>MODEL</b>	<b>KW</b>	<b>"A"</b>	<b>"B"</b>
ADE-215	15	5	67
ADE-220	15	N/A*	
ADE-230	15		
UDE-50	20	2	65
	24	4	81
	30	5	72
ADE-100	60	2	60
ADE-120	72	5	80
	80	5	90

<b>STEAM</b>			
<b>MODEL</b>	<b>TYPE</b>	<b>"A"</b>	<b>"B"</b>
UDS-50	High or Low	N/A*	
ADS-80		5	65
UDS-80		5	65
ADS-100		5	80
	N/A*		
	Super Steam	5	75
ADS-120	High or Low	N/A*	
ADS-120 (D)		5	73
ADS-170		5	75

\* “A” and “B” Factors not available at time of printing.

**PHASE 5 “A” and “B” Factor Parameter Listing for *Current Production Models* are on the previous page (page 59).**

- (A) For **60 Hz** models *ONLY*.
- (B) For **50 Hz** models *ONLY*.
- (C) For non-Heat Reclaimer models *ONLY*.
- (D) For models manufactured with an *OPTIONAL* Heat Reclaimer (HR) *ONLY*.

**IMPORTANT:** The “A” and “B” Factors have been preprogrammed by the factory and *should not be* changed in the field unless the Phase 5 Microprocessor Controller (computer) should fail and is being replaced. **THE REPLACEMENT PHASE 5 MICROPROCESSOR CONTROLLER (COMPUTER) MUST BE REPROGRAMMED FOR THE SPECIFIC MODEL DRYER and HEATING UNIT AS SHOWN IN THE CHARTS ABOVE.**



# SECTION XI

## PHASE 5 OPL SYSTEM DIAGNOSTICS

**IMPORTANT: YOU MUST DISCONNECT AND LOCKOUT THE ELECTRIC SUPPLY AND THE GAS SUPPLY OR THE STEAM SUPPLY BEFORE ANY COVERS OR GUARDS ARE REMOVED FROM THE MACHINE TO ALLOW ACCESS FOR CLEANING, ADJUSTING, INSTALLATION, OR TESTING OF ANY EQUIPMENT PER OSHA (Occupational Safety and Health Administration) STANDARDS.**

ALL major circuits, including door, microprocessor temperature sensor, heat and motor circuits are monitored. The Phase 5 OPL microprocessor controller (computer) will inform the user, via the L.E.D. (light emitting diode) display of certain failure codes, along with indicators both in L.E.D. display and at the output of each relay (and door switch circuit) to easily identify failures.

### A. DIAGNOSTIC (LIGHT EMITTING DIODE [L.E.D.] DISPLAY) FAILURE CODES

1. **“door”** - indicates door switch circuit is open.
  - a. Keyboard (touchpad) entry was made while main door is open,  
or,
  - b. There is a fault in the door switch circuit (external of the Phase 5 OPL microprocessor controller [computer]).
2. **“dSFL”** - indicates a fault in the microprocessor temperature circuit.
  - a. If a fault is detected in the microprocessor heat sensor circuit, the L.E.D. display will read **“dSFL”** and the Tone (buzzer) will sound for approximately 5-seconds, every 30-seconds until...
    - 1) The problem is corrected,  
or,
    - 2) The power to the dryer is discontinued (and the problem is corrected).

**IMPORTANT:** The Phase 5 OPL microprocessor controller (computer) has its own internal heat sensing circuit fuse protection which is located on the back side of the Phase 5 OPL microprocessor controller (computer), refer to the illustration on **page 63**. If a **“dSFL” condition** occurs, check to see if the fuse has blown. **If it has, DO NOT replace the entire Phase 5 OPL computer; REPLACE ONLY THE FUSE and do so only with an 1/8-Amp (Slo-Blo) fuse ONLY.**

**NOTE:** Once the Phase 5 OPL microprocessor controller (computer) detects a problem in the heat circuit, it updates every 30-seconds, so that if the problem was a loose connection in this circuit which corrected itself the **“dSFL”** condition would automatically be cancelled.

3. **“SEFL”** - indicates a rotational sensor circuit failure meaning that there is a fault somewhere in the basket (tumbler) rotation circuit, or, the Phase 5 OPL microprocessor controller (computer) program related to this circuit (Program Location 2 [**PL02**]) is set incorrectly, in the active mode (**“SEn”**), whereby the dryer is not equipped with the optional rotational sensor and **should be** set in the non-active mode (**“nSEn”**).
4. **“Hot”** - indicates a possible overheating condition. The Phase 5 OPL microprocessor controller (computer) monitors the temperature in the dryer at **ALL** times. If the Phase 5 OPL microprocessor controller (computer) detects that the temperature in the dryer has exceeded 220° F (104° C), it will disable **ALL** outputs (shut the dryer down), the Tone (buzzer) will sound for approximately 5-seconds, and the L.E.D. (light emitting diode) display will read **“Hot.”** The L.E.D. display will continue to read **“Hot”** until the temperature sensed has dropped below 220° F (104° C) or lower and the Phase 5 OPL microprocessor controller (computer) is manually reset by pressing the **“CLEAR/STOP”** key.

## B. L.E.D. DISPLAY FAILURE INDICATORS

The L.E.D. indicator dots located on the top portion of the L.E.D. display indicate the various Phase 5 OPL computer functions while a cycle is in progress. These indicator dots (as shown in the illustration below) **DO NOT** necessarily mean that the outputs are functioning. They are only indicating that the function (output) **should be** active (on).

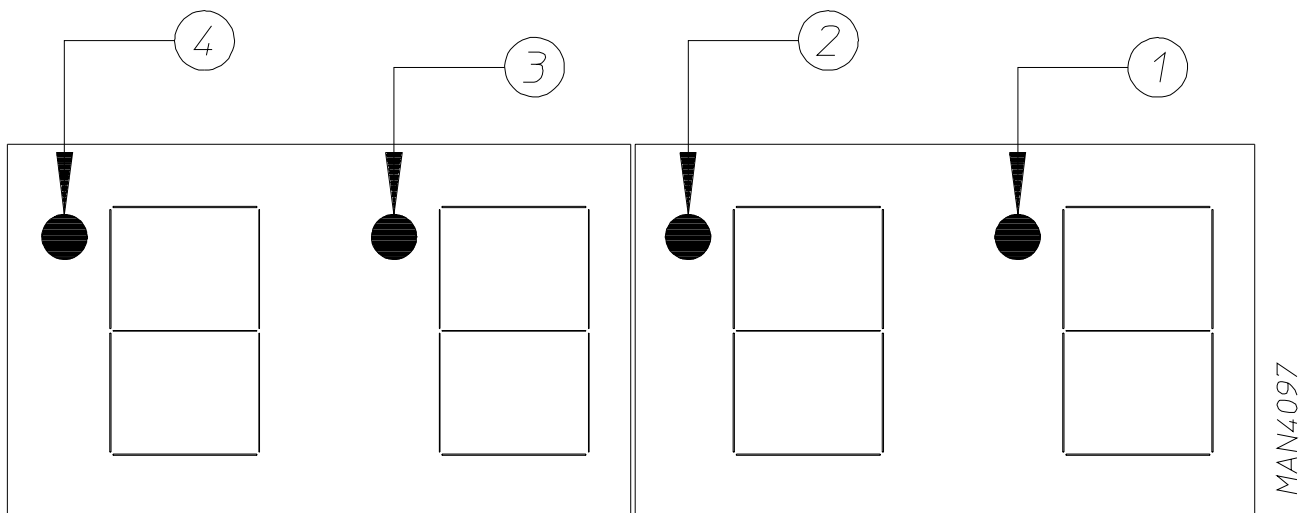

### 1. L.E.D. Display Indicator **Number 1**

#### a. Blower Motor Circuit Indicator;

- 1) This indicator dot is on whenever a cycle is in progress.

### 2. L.E.D. Display Indicator **Number 2**

#### a. Heat Circuit Indicator;

- 1) This indicator dot is on whenever the Phase 5 OPL microprocessor controller (computer) is calling for the heating circuit to be active (on).

3. L.E.D. Display Indicator **Number 3**

a. For *Optional Reversing Models*;

- 1) This indicator dot is on when the drive (basket [tumbler]) motor is operating in the reversing mode (counterclockwise [CCW] direction).

4. L.E.D. Display Indicator **Number 4**

a. For *Optional Reversing Models*;

- 1) This indicator dot is on when the drive (basket [tumbler]) motor is operating in the forward mode (clockwise [CW] direction).

### C. PHASE 5 OPL MICROPROCESSOR CONTROLLER (COMPUTER) RELAY OUTPUT L.E.D. INDICATORS

There are a series of five (5) L.E.D. (light emitting diode) indicators (red lights) located at the lower back side area of the Phase 5 OPL microprocessor controller (computer). These are identified or labeled from left to right in the illustration below as “HEAT,” “MTR” (motor), “FWD” (forward), “REV” (reversing), and “DOOR.” These L.E.D.s indicate that the outputs of the Phase 5 OPL microprocessor controller (computer), or, in the case of the door switch input, are functioning.

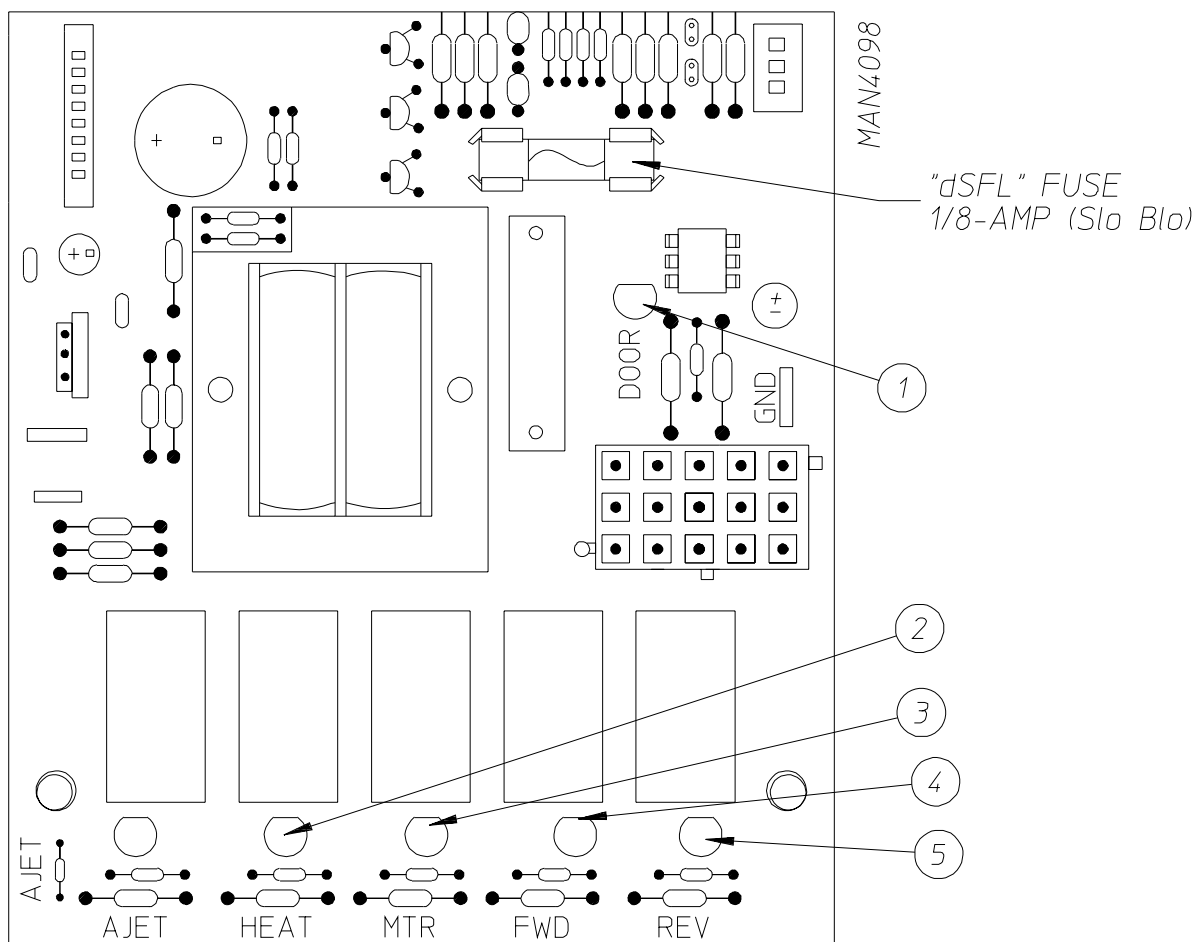

1. **“DOOR”** L.E.D. (light emitting diode) Indicator

- a. **SHOULD BE ON ALL THE TIME** (*even if the dryer is not running*) unless the main door, lint door or draw is open or there is a problem (open circuit) in the main or lint door switch circuit.

**NOTE:** If the dryer is started (display indicator dots are on) and there are no outputs (“**HEAT**” and/or “**MTR**” output L.E.D.’s are off) and the “**DOOR**” input L.E.D. is on; then the fault is the Phase 5 OPL microprocessor controller (computer) itself.

If the failure was elsewhere (i.e., the dryer’s door switch circuit), the L.E.D. (light emitting diode) display would read “**door**” if a keyboard (touchpad) entry was attempted.

If the display indicator dots are on, and the “**DOOR**” L.E.D. input and the motor/heat output L.E.D.’s are on, yet the motor and/or heat *is not active (on)*; then the problem is elsewhere in the dryer.

2. **“HEAT”** Output L.E.D. Indicator

- a. If the dryer is started and there is NO “**HEAT**,” yet the Phase 5 OPL microprocessor controller (computer) display heat circuit indicator dot is on, but the “**HEAT**” output L.E.D indicator is off; then the fault is the Phase 5 OPL microprocessor controller (computer) itself.
- 1) If both the display indicator dot and the “**HEAT**” output L.E.D. indicator dot are on; then the problem (fault) is elsewhere (i.e., external to the Phase 5 OPL microprocessor controller [computer]).

3. **“MTR”** Output L.E.D. Indicator

- a. If the dryer is started and the blower (impellor/fan) motor *is not operating*, yet both the Phase 5 OPL microprocessor controller (computer) display blower (impellor/fan) motor indicator dot and “**DOOR**” input L.E.D. indicator dot is off; then the fault is the Phase 5 OPL microprocessor controller (computer) itself.
- 1) If the motor *is not operating* and the “**MTR**” output indicator is on; then the problem (fault) is elsewhere (i.e., external to the Phase 5 OPL microprocessor controller [computer]).

4. **“FWD”** Output L.E.D. Indicator  
(for Optional Reversing Models Only)

- a. If the dryer is started and the blower (impellor/fan) motor is operating but the drive (basket/tumbler) motor *is not*, yet the Phase 5 OPL microprocessor controller (computer) display “**FORWARD**” indicator dot is on, but the “**FWD**” (forward) motor output L.E.D. is off; then the fault is the Phase 5 OPL microprocessor controller (computer) itself.
- 1) If the drive (basket/tumbler) motor *is not operating* and the “**FWD**” indicator is on; then the problem (fault) is elsewhere (i.e., external to the Phase 5 OPL microprocessor controller [computer]).

5. **“REV”** Output L.E.D. (light emitting diode) Indicator  
**(for Optional Reversing Models ONLY)**

- a. If the dryer is started and the blower motor is operating but the drive (basket [tumbler]) motor is not, yet the Phase 5 OPL microprocessor controller (computer) display “REVERSE” indicator dot is on, but the “REV” (reverse) motor output L.E.D. is off; then the fault is the Phase 5 OPL microprocessor controller (computer) itself.
  - 1) If the drive (basket [tumbler]) motor is not operating and the “REV” indicator is on; then the problem (fault) is elsewhere (i.e., external of the Phase 5 OPL microprocessor controller [computer]).

## SECTION XII

### OPTIONAL 9 VOLT BATTERY BACK-UP

Dryers ordered from the factory with the 9 Volt Battery Back-Up Option (*battery is not included*) allow the Phase 5 OPL microprocessor controller (computer) to maintain its operating status should a momentary power interruption occur while the dryer cycle is in progress.

**It is suggested that the battery be replaced at least once a year or as found necessary.** The battery life will depend on the age of the battery, the amount of power interruptions, and the back-up time used.

**IMPORTANT: For proper operation use ALKALINE BATTERIES ONLY. Suggest Eveready Energizer, Duracell, or its equivalent. DO NOT USE CARBON TYPE BATTERIES.**

<b>ADC 112147</b>	<b>1</b> - 01/15/92-750	<b>2</b> - 05/01/92-500	<b>3</b> -07/01/92-500
	<b>4</b> - 08/03/92-1,000	<b>5</b> - 12/11/92-500	<b>6</b> - 04/11/93-500
	<b>7</b> - 06/01/93-500	<b>8</b> - 07/13/93-500	<b>9</b> - 10/05/93-500
	<b>10</b> - 12/13/93-500	<b>11</b> - 01/28/94-500	<b>12</b> * 04/01/94-500
	<b>13</b> * 06/24/94-500	<b>14</b> - 07/01/94-500	<b>15</b> - 08/24/94-500
	<b>16</b> - 09/20/94-500	<b>17</b> - 11/14/94-1,000	<b>18</b> - 12/03/95-1,000
	<b>19</b> - 03/27/95-1,000	<b>20</b> - 07/27/95-1,000	<b>21</b> - 11,14/95-1,000
	<b>22</b> - 03/22/96-1,000	<b>23</b> - 05/23/96-1,000	<b>24</b> * 09/03/96-1,500
	<b>25</b> - 02/18/97-1,500	<b>26</b> - 07/25/97-1,500	<b>27</b> - 12/19/97-1,500
	<b>28</b> - 05/05/98-1,500	<b>29</b> * 08/28/98-1,500	<b>30</b> - 03/09/99-1,500
	<b>31</b> - 09/07/99-1,500	<b>32</b> * 04/07/00-500	<b>33</b> - 05/26/00-500
	<b>34</b> - 08/03/00-500	<b>35</b> - 10/02/00-500	<b>36</b> * 01/22/01-500
	<b>37</b> - 04/25/01-500	<b>38</b> * 07/26/01-500	<b>39</b> * 11/09/01-500
	<b>40</b> - 05/14/02-500	<b>41</b> * 04/04/03-100	

