

PLC User's Manual Vol III

WARNING: For your safety the information in this manual must be followed to minimize the risk of fire or explosion or to prevent property damage, personal injury or death.

— Do not store or use gasoline or other flammable vapor and liquids in the vicinity of this or any other appliance.

— **WHAT DO YOU DO IF YOU SMELL GAS**

- * Do not try to light any appliance.
- * Do not touch any electrical switch; do not use any phone in your building.
- * Clear the room, building or area of all occupants.
- * Immediately call your gas supplier from a neighbor's phone. Follow the gas supplier's instructions.
- * If you cannot reach your gas supplier, call the fire department.

— Installation and service must be performed by a qualified installer, service agency or the gas supplier.

AVERTISSEMENT: Assurez-vous de bien suivre les instructions données dans cette notice pour réduire au minimum le risque d'incendie ou d'explosion ou pour éviter tout dommage matériel, toute blessure ou la mort.

— Ne pas entreposer ni utiliser d'essence ni d'autres vapeurs ou liquides inflammables dans le voisinage de cet appareil ou de tout autre appareil.

— **QUE FAIRE SI VOUS SENTEZ UNE ODEUR DE GAZ:**

- * Ne pas tenter d'allumer d'appareil.
- * Ne touchez à aucun interrupteur. Ne pas vous servir des téléphones se trouvant dans le bâtiment où vous vous trouvez..
- * Évacuez la pièce, le bâtiment ou la zone.
- * Appelez immédiatement votre fournisseur de gaz depuis un voisin. Suivez les instructions du fournisseur.
- * Si vous ne pouvez rejoindre le fournisseur de gaz, appelez le service des incendies.

— L'installation et l'entretien doivent être assurés par un installateur ou un service d'entretien qualifié ou par le fournisseur de gaz.



For replacement parts, contact the distributor from which the dryer was purchased or

American Dryer Corporation

88 Currant Road

Fall River MA 02720-4781

Telephone: (508) 678-9000 / Fax: (508) 678-9447

e-mail: techsupport@amdry.com

Retain This Manual In A Safe Place For Future Reference

American Dryer Corporation products embody advanced concepts in engineering, design, and safety. If this product is properly maintained, it will provide many years of safe, efficient, and trouble-free operation.

ONLY qualified technicians should service this equipment.

OBSERVE ALL SAFETY PRECAUTIONS displayed on the equipment or specified in the installation/operator's manual included with the dryer.

The following "FOR YOUR SAFETY" caution must be posted near the dryer in a prominent location.

FOR YOUR SAFETY

Do not store or use gasoline or other flammable vapors or liquids in the vicinity of this or any other appliance.

POUR VOTRE SÉCURITÉ

Ne pas entreposer ni utiliser d'essence ni d'autres vapeurs ou liquides inflammables dans le voisinage de cet appareil ou de tout autre appareil.

We have tried to make this manual as complete as possible and hope you will find it useful. ADC reserves the right to make changes from time to time, without notice or obligation, in prices, specifications, colors, and material, and to change or discontinue models.

Important

For your convenience, log the following information:

DATE OF PURCHASE _____ MODEL NO. _____

DISTRIBUTORS NAME _____

Serial Number(s) _____

Replacement parts can be obtained from your distributor or the ADC factory. When ordering replacement parts from the factory, you can FAX your order to ADC at (508) 678-9447 or telephone your orders directly to the ADC Parts Department at (508) 678-9000. Please specify the dryer model number and serial number in addition to the description and part number, so that your order is processed accurately and promptly.

"IMPORTANT NOTE TO PURCHASER"

Information must be obtained from your local gas supplier on the instructions to be followed if the user smells gas. These instructions must be posted in a prominent location near the dryer.

IMPORTANT

YOU MUST DISCONNECT and LOCKOUT THE ELECTRIC SUPPLY and THE GAS SUPPLY or THE STEAM SUPPLY BEFORE ANY COVERS or GUARDS ARE REMOVED FROM THE MACHINE TO ALLOW ACCESS FOR CLEANING, ADJUSTING, INSTALLATION, or TESTING OF ANY EQUIPMENT per OSHA (Occupational Safety and Health Administration) STANDARDS.

“Caution: Label all wires prior to disconnection when servicing controls. Wiring errors can cause improper operation.”

«Attention: Lor des opérations d'entretien des commandes étiqueter tous fils avant de les déconnecter. Toute erreur de câblage peut être une source de danger et de panne.»

CAUTION

DRYERS SHOULD NEVER BE LEFT UNATTENDED WHILE IN OPERATION.

WARNING

**CHILDREN SHOULD NOT BE ALLOWED TO PLAY ON OR NEAR THE DRYERS.
CHILDREN SHOULD BE SUPERVISED IF NEAR DRYERS IN OPERATION.**

FOR YOUR SAFETY

DO NOT DRY MOP HEADS IN THE DRYER.

DO NOT USE DRYER IN THE PRESENCE OF DRY CLEANING FUMES.

WARNING

UNDER NO CIRCUMSTANCES should the door switch or the heat circuit devices ever be disabled.

WARNING

The dryer must never be operated with any of the back guards, outer tops, or service panels removed. PERSONAL INJURY or FIRE COULD RESULT.

WARNING

DRYER MUST NEVER BE OPERATED WITHOUT THE LINT FILTER (SCREEN) IN PLACE, EVEN IF AN EXTERNAL LINT COLLECTION SYSTEM IS USED.

IMPORTANT

PLEASE OBSERVE ALL SAFETY PRECAUTIONS displayed on the equipment or specified in the installation/operator's manual included with the dryer.

Dryers must not be installed or stored in an area where it will be exposed to water or weather.

The wiring diagram for the dryer is located in the front electrical control box area.

Table of Contents

SECTION I	3
THE CONTROL SYSTEM	3
INTRODUCTION	3
“TOTAL CUSTOMER SATISFACTION.”	3
SECTION II	4
FEATURES	4,5
SECTION III	6
COMPUTER CONTROL	6
OPERATIONAL INSTRUCTIONS	6
1.0 Basic Definitions	6
1.1 Keypad and Computer	6
1.2 Pendant and Rear Controls	6,7
1.3 Control Cabinet Door	7
SECTION IV	8
LOAD / DRYING / UNLOADING OPERATION	8
1.0 Switching Power to the Unit	8
1.1 Switching the Control Voltage On	8
1.2 Loading the Dryer	8,9
1.3 Running a Drying Cycle	8,9
1.3.1 One-Key Start (preprogrammed cycles)	9
1.3.2 Manually Input Cycles	9
1.3.3 Drying Cycle Sequence of Events	9
1.3.4 Reversing and Non-Reversing Cycles	10
1.3.5 Drying Temperatures and Operating Sensors	10
1.3.6 Dryness Level and Elapsed Time	10
1.3.7 Cool Down Cycle	10
1.3.8 Stopping the Dryer	11
1.3.9 End of Cycle Audio/Visual Indicator	11
1.3.10 Anti-Wrinkle Guard Feature	11
1.4 Unloading a Single Door Dryer	11
1.4.1 Unloading a Two Door Dryer	11
1.4.2 Unloading Safety (Two Door Dryer)	12
1.5 Leveling the Dryer	12
SECTION V	13
PROGRAMMING INSTRUCTIONS	13
1.0 Programming the System	13
1.1 Entering the Programming Mode and Access Codes	13
1.2 System Program Mode (code 1234)	13
1.2.1 Loading Position	13,14
1.2.2 Unloading Point	14

1.2.3 Spin Time (drum forward or reverse)	14
1.2.4 Dwell Time (stop time between rotation directions)	14,15
1.3 - Preprogrammed Cycle Mode (code 5678)	15
1.3.1 Drying Mode (automatic or manual cycle)	15
1.3.2 - Drying Time (manual) or Dryness Level (auto).....	16
1.3.3 Drying Sensor (intake or exhaust)	16
1.3.4 Drying Temperature	16
1.3.5 Cool Down Time	17
1.3.6 Reversing or Non-Reversing Cycle	17
1.3.7 Programming More Automatic Start Keys	17
SECTION VI	18
DIAGNOSTICS, MESSAGES, AND INPUT / OUTPUT INDICATORS	18
1.0 Display Messages	18
2.0 Input and Output Indicators	19,20
3.0 Other Indicators	21
SECTION VII	22
BATTERY BACK-UP	22
1.0 INSTALLING THE BATTERY	22
SECTION VIII	23
LANGUAGE AND MEMORY CARTRIDGE REPLACEMENTS	23
1.0 INSTALLING A MODULAR	23
SECTION IX	24
FACTORY PRESET PROGRAMS	24
SYSTEM PARAMETERS:	24
SECTION X	25
PROGRAMMING LIMITS	25
SECTION XI	26
REPLACEMENT PARTS-LIST	26
SECTION XII	27
APPENDIX	27
1. PLC Display Terminal	27
2. Micro-PLC	28
3. Analog Input Module	29
4. Output Module.....	29
5. Lithium Battery	30
6. RS232 Cable	30
7. Bus Terminator	31
8. Language and Memory Cartridges	31

SECTION I

THE CONTROL SYSTEM

INTRODUCTION

American Dryer Corporation's large dryers are State of the Art drying machines.

Its drying performance is based on high output, maximum efficiency, and solid reliability - three key factors define the quality of this type of machine today.

To attain this industrial dryer's high performance level, ADC utilized the soundest engineering solutions and the best quality of components throughout the dryers design with one simple goal in mind:

"TOTAL CUSTOMER SATISFACTION."

The dryer's controls were designed to maximize functionality and built-in flexibility with simplicity in mind.

Specifically, this functionality is possible by utilizing simple, effective, and easy-to-use controls, such as, a front remote loading /unloading pendant station that walks with the user for ease of operation, a built-in rear panel unloading station for optional rear unloading, or a simple one-button dryer start that the attendant can use to initiate any of the six preprogrammed cycles in both the manual (timed) or the automatic (percent dry) modes of operation. In the automatic drying mode of operation (ADC U.S. patent no. 4,827,627), the dryer stops automatically as soon as the load is dry, therefore, eliminating wasted energy and time.

The dryer control system utilizes computer technology that allows the user to simply place the load in the dryer and push one single button to start a given drying cycle. The computer will directly monitor the moisture content of the load and stop the dryer automatically when the selected dryness level is reached.

SECTION II

FEATURES

1. Reliable, industrial hardened, computer control.
2. All computer programming is done through the keypad at the front of the unit.
3. Automatic Drying Cycle (Patent no. 4,827,627) - Computerized monitoring of the load dryness for precise, fast, and efficient drying.
4. Timed (manual) Drying Cycle - For special loads, programming allows for a predefined amount of time for both drying and cool down cycles.
5. Preprogrammed Cycles - The computer system can store in its memory six preprogrammed cycles in either the automatic or manual modes of operation.
6. Manually Loaded Cycles - For occasional or one-time special loads, the user can set a specific program in either the automatic drying (Patent no. 4,827,627) cycle or timed cycle.
7. Variable (programmable) temperature selections to accommodate the type of fabric to be dried.
8. Variable (programmable) cool down selections to help eliminate wrinkled loads.
9. Display Terminal - Industrial grade terminal display informs the user of cycle status and programs and also displays important system diagnostic messages.
10. Anti-wrinkle Program - Helps keep items wrinkle free when they are not removed from the dryer promptly at the end of the drying and cooling cycles.

11. **Diagnostics** - All major circuits, including doors, temperature, air, gas, and general safeties, are monitored throughout the drying cycle. Should the computer detect an abnormal situation at anytime in the dryer, depending on the severity of the situation, it will take different actions and with the use of the front cabinet display give an indication to what the problem might be.

12. **Audio/ Visual Signal** - An audible tone will sound and a strobe light will be enabled to indicate the drying cycle is complete.

13. **The computer system can monitor the temperature in both Celsius or Fahrenheit for ease of operation.**

14. **High-Temperature Protection** - If the computer senses that the drying temperature in the intake or the exhaust has reached the preset high limits, it will stop the dryer completely, and the corresponding diagnostic message will be displayed, indicating the overheating problem.

15. **Reversing Cycles** - To eliminate wrinkling due to the balling up or tangling of large items, the PLC uses a cycle reversing option where the tumbler will turn in the forward direction, stop, and reverse direction of rotation for a predefined period of time. The dryer will repeat this action for the entire drying cycle.

16. **Independent loading and unloading controls for both front and rear of the dryer.**

SECTION III

COMPUTER CONTROL **OPERATIONAL INSTRUCTIONS**

1.0 Basic Definitions

The dryers controls are composed of two basic sections, the drying controls and the loading and unloading controls.

1.1 Keypad and Computer

The drying control section uses an industrial grade keypad and display combination to provide ease of dryer / operator dialogue and a computer to control all of the typical functions necessary to effect a drying cycle.

1.2 Pendant and Rear Controls

The loading and unloading controls are located in two places, the front pendant and rear panel. These controls are designed to enable the operator to load or unload the dryer from the front or rear. The pendant control situated at the front of the dryer contains four switches:

- A three-position selector for loading, leveling, and unloading the dryer from the front of the unit.
- Two jog buttons (one for the forward and another for the reverse direction of rotation of the drum while loading or unloading), and
- An emergency stop button to halt the unit from the pendant in case of a hazardous situation.

The rear controls panel located close to the rear door is used exclusively to unload the unit and consists of a two-position unload/level selector, two jog buttons (one for the forward and the other

for reverse direction of rotation of the drum while unloading), and an emergency stop button to halt the unit should a hazardous situation arise.

Only one control station is capable to control the dryer at any given time. All others are locked out. Both the rear panel and the front pendant controls are independent from the computer terminal but share the PLC to control air solenoids, drum motor, contractors, etc, needed to load or unload the dryer.

1.3 Control Cabinet Door

The electrical cabinet door is used to mount the I/O terminal, on, off, emergency stop, and sprinkler reset buttons as well as the main power switch, dryer power, and sprinkler power indicators.

- The on and off buttons are used to switch electrical power to supply all the machine power switches with control voltage.
- The emergency stop button interrupts power to the control circuits in case of an emergency, to completely stop the dryer.
- The sprinkler reset button, as its name suggests, cancels the operation of the safety sprinkler that will come on in case of a fire being detected inside of the drum. The sprinkler system is independently powered and connected upstream from the main dryer power switch and on its own separate electric service.
- The main power switch is used to totally disconnect electrical power to the dryer manually for service or installation, or automatically in case of detected under voltage condition or a detected fire inside of the drum.

SECTION IV

LOAD / DRYING / UNLOADING OPERATION

1.0 Switching Power to the Unit

- To power up the unit, the operator must first switch the sprinkler power electric service on at the wall disconnect. The control cabinet will respond by turning on the red indicator light which is labeled "Sprinkler Power." *The dryer will not operate without the sprinkler control section being powered.*
- Next, the operator must switch power to the dryer by turning the second electric service on at the wall disconnect.
- At this point, the user can apply power to the dryer by turning the main power switch handle to the on position on the control door. The dryer will respond by illuminating the blue indicator light labeled "Power On." Upon power up, the PLC (programmable logic controller), terminal, and all other controlling devices will be powered up and will run internal self-test routines. Upon successful completion of diagnostics, the PLC will monitor all of its inputs and wait. The I/O terminal will display "Cntrl Volt Off."

1.1 Switching the Control Voltage On

At this point, the user must switch the control voltage on which on command, supplies power to all dryer actuators. This is done by pressing the green push button on the control cabinet. The control system will apply 110 volts to all the common points via a master control relay (MCR) and turn on the green indicator light on the control cabinet labeled "ON." Since the computer is monitoring the control voltage at all times and it now senses this voltage has been turned on, it will respond by displaying the message "***AD####*" on the screen. The dryer is now ready to accept any drying or loading commands.

1.2 Loading the Dryer

To load the dryer, the operator will assign computer control to the pendant by placing the

three-position selector control in the "LOAD" position. All other controls are at that point locked out. When the "LOAD" switch is activated, the dryer will assume loading position by opening the front doors, and tilting, if load level has not been selected. The dryer will remain in that position, where a load can be placed in the drum until another command is issued. The operator may use jog buttons on the front pendant control to aid in this operation.

Should an emergency situation arise, the entire dryer may be stopped by pressing the emergency stop switch located on the pendant station. When loading of the dryer is complete, the operator will close the doors and level the dryer by turning the selector switch to the "LEVEL" position. At this point, computer control will be released from the pendant station and all other controls unlocked. The dryer is now ready to start a drying cycle.

1.3 Running a Drying Cycle

1.3.1 One-Key Start (preprogrammed cycles)

The operator may start a drying cycle immediately by pressing one single key at the keypad on the I/O terminal, using one of the preprogrammed drying cycles residing on the key switches "A" thru "F" in either the Automatic (i.e., patented) or the Manual (i.e., timed) drying modes of operation.

1.3.2 Manually Input Cycles

For less frequently used load sizes or materials, the operator may manually enter a special drying cycle in both the automatic or manual mode of operations by pressing either the "Auto" or "Man" keys on the terminal keypad. For these manually input cycles, the computer will ask the operator for drying parameters, such as, dryness level in percent and drying temperature for the automatic mode, or drying time and temperature for manual mode.

1.3.3 Drying Cycle Sequence of Events

Once the operator initiates a drying cycle by either "one-key start" or "manual entry," the dryer will begin by starting the drum, the main fan, and the combustion blower. Once the heating unit is on, the controls will put the exhaust/recirculate damper in the recirculate position. This position conserves energy throughout the heated portion of the cycle, by recirculating the heat that would have been exhausted, back into the drum.

1.3.4 Reversing and Non-Reversing Cycles

During the entire cycle, the drum will rotate in the clockwise rotation only or alternately clockwise and counterclockwise if the drying cycle selected was non-reversing or reversing , respectively. Spin and stop times are adjustable and defined in the system configuration portion of the program mode to be described in section V Programming Instructions.

1.3.5 Drying Temperatures and Operating Sensors

Throughout the heated portion of the drying cycle, the dryer will seek the selected drying temperature set point. The actual drying temperatures are measured by the exhaust or optional intake sensor probe. Drying temperature ranges vary from inlet to exhaust and have the following adjustment ranges:

Manual Mode	Automatic Mode
Intake: 250 to 350 F (120 to 177°C)	Intake: Not Applicable
Exhaust: 100 to 210 F (38 to 99°C)	Exhaust: 160 to 210 F (70 to 99°C)

During this portion of the drying cycle the controls will turn the heat high and low to maintain the selected temperature set point previously defined in the cycle. Temperature readings and drying information will alternate on the display at a 3-second rate throughout the heated portion of the cycle.

1.3.6 Dryness Level and Elapsed Time

When the dryer reaches either the selected dryness level, (automatic drying mode) or the preset time (manual drying mode), the burner will be switched off, the damper will return to the exhaust position, and the dryer will proceed into the cool down portion of the cycle.

1.3.7 Cool Down Cycle

During the cool down portion of the cycle, the heating unit will be disabled but the drum, fan and lint cleaning mechanism will remain on. When the preset cool down time value has elapsed, the controls will stop the drum, and main fan.

1.3.8 Stopping the Dryer

The dryer may be stopped completely at any point of any drying cycle by pressing the “stop” key at the terminal keypad. If a cycle is stopped in this fashion, the computer will disable all outputs and write “**AD-***” on the display.

1.3.9 End of Cycle Audio/Visual Indicator

When a cycle has ended, the computer will write “Done” on the display, enable a buzzer for 8 seconds, and an orange strobe light will flash to indicate to the operator that the drying cycle is complete.

1.3.10 Anti-Wrinkle Guard Feature

If the dryer is left unattended for a predefined period of one minute, the anti-wrinkle guard program will periodically engage the fan and drum 90 seconds to prevent wrinkles in the dried articles and possible fires produced by spontaneous combustion. This program will remain on for a predefined maximum guard time of 30 minutes. After the anti-wrinkle guard maximum period has elapsed, the dryer will display “**AD-***” on the screen and stop. The orange strobe light will continue to flash to signal the operator that the cycle is complete.

1.4 Unloading a Single Door Dryer

Unloading a single door dryer must be done from the front pendant. To unload the dryer the operator must turn the control selector switch to the “UNLOAD” position. The end of cycle strobe light will be shut off, the display will read “AD***”, and the dryer will assume the unload position with the doors open. For a quicker unload, manually jog the drum either in forward or reverse direction. The jog controls are located on the front pendant.

1.4.1 Unloading a Two Door Dryer

Unloading of the dryer can be done from the front or from the rear of the dryer, depending on the unloading setting previously programmed into the system. Unloading can be done with the help of the front pendant or the rear panel controls. When either one of the unloading controls is activated, the end-of-cycle strobe light will be shut off and the display will return to read the initial message “**AD-***.” To unload the dryer, the operator must place either the pendant or rear control selector switch in the “UNLOAD” position as previously defined in the system program parameters.

1.4.2 Unloading Safety (Two Door Dryer)

For safety reasons, only one unloading station is active at a time (Front or Rear). The other is locked out at the time the user defines the dryer unloading point in the system program mode. Thus, if, for example, the dryer was configured to unload at the front, then the rear controls will always be disabled. Conversely, if the dryer was configured to unload from the rear, the front unloading button will be disabled.

At this point, the terminal will be disabled, and unloading can begin from either the front or the rear of the dryer as previously stipulated in the system configuration. When either unloading control is enabled by placing the selector switch in the "UNLOAD" position, the dryer will open the respective doors and tilt to the proper position (i.e., front or rear). Again, the operator may speed up the unloading phase by jogging the drum clockwise or counterclockwise using the respective push-buttons available at either unloading station, letting gravity do the rest.

1.5 Leveling the Dryer

When this operation is complete, the user may close the unloading doors and level the dryer by placing the selector switch in the "LEVEL" position. All controls are totally interlocked throughout all operations so that no hazardous situations may result. At this point, the operator may choose to continue and begin another cycle by loading the dryer in the same fashion as described above or relinquish control to the terminal.

SECTION V

PROGRAMMING INSTRUCTIONS

1.0 Programming the System

The dryer's computer system also includes a mode in which the user can configure two areas of the system. One area of the programming mode is called the system program mode, and the other, the preprogrammed cycle mode. All programming for the system is done by the user, directly from the front of the control cabinet through the use of the I/O terminal which consists of a numeric keypad and an alphanumeric display. Throughout programming the computer will prompt the user to answer specific questions. Since the keypad includes only numeric characters, the user responses will be limited to one ("1") or zero ("0").

1.1 Entering the Programming Mode and Access Codes

The user can enter the program mode by pressing the "Prog" key on the terminal's keypad, in which case, the computer will respond by displaying the message "Code." At this point, the user is being asked to enter one of the access codes which will permit entering in either area of the program areas. For simplicity, at this point, code 1234 will give access to the system program mode and code 5678 to the preprogram cycle mode.

1.2 System Program Mode (code 1234)

Press the "Prog" key on the keypad. The display will read "Code ____."

Enter "1234" and press the enter key. After the computer validates the code, it will display the first parameter within this mode.

1.2.1 Loading Position

The first system parameter to be defined is the loading position. The dryer offers the option of being loaded in the leveled or tilted positions.

When the computer displays the prompt “Load L=1/T=0__,” enter the position of your choice by placing a “0” or a “1” in the blinking field of the message. A “1” will configure the computer that the user is loading in the level position, and a “0” for the tilted position.

After entering the number of your choice, validate it with the use of the enter key. After the enter key is pressed, the computer will save the load setting and advance to the next parameter to be entered.

1.2.2 Unloading Point

The next parameter to be defined is the unloading point. The dryer offers the possibility of unloading from the front or from the rear.

When the computer displays the message “Unld F=1/R=0 __,” enter the unloading point of your choice by placing a “0” or a “1” in the blinking field of message. Entering a “0” will configure the system to unload at the rear of the dryer, and a “1” at the front. Again, validate your selection by pressing the enter key. After the enter key is pressed, the computer will save the unload setting and advance to the next parameter to be selected.

1.2.3 Spin Time (drum forward or reverse)

In this next parameter, the user is asked for the spin time, which specifies the amount of time that the drum will rotate in either the forward or reverse direction, for the reversing drying cycles. The dryer offers an adjustable spin time range from 15 to 99 seconds in one-second increments.

When the computer displays the message “Spin Time __,” enter the amount of time of your choice and validate it by pressing the enter key. Again, the computer will save the selection of your choice and proceed to the last system parameter to be defined.

1.2.4 Dwell Time (stop time between rotation directions)

The last parameter is the dwell time, which specifies the amount of time that the computer will allow the drum to stop before changing direction of rotation. The dryer allows this time selection to be adjusted from 4 to 9 seconds in one-second increments.

When the computer displays the message “Dwell Time __,” enter the amount of time of your choice and again validate it for the computer to save your selection.

At this point, the system program is complete, and the computer will return to the run mode by displaying the "***AD-###**" message.

1.3 - Preprogrammed Cycle Mode (code 5678)

Press the "Prog" key on the keypad. The display will read "Code___."

Enter "5678" and press the enter key.

After the computer validates the code, it will display the next prompt which is "Press A-F Key."

At this point, the computer is waiting for the user to press one of the available preprogrammed cycle keys from "A" to "F."

When one of the (A-F) keys is pressed, the computer will prompt the user to enter specific cycle parameters which will reside under that key.

1.3.1 Drying Mode (automatic or manual cycle)

The first selection that the computer needs in a given drying cycle is the drying mode. The dryer offers the options of drying in either the automatic percent dry (ADC patent no. 4,827,627) or a manual (timed) modes of operation.

When the computer displays the message "Man=1 / Auto=0 __," enter your drying mode selection by placing a "1" for manual mode or a "0" for the automatic mode of drying in the blinking section of the message. Validate your selection by pressing the enter key. After the computer validates the selection, it will store it and advance to the next selection.

The next selection can be either drying time or dryness level, depending on the selection entered in the previous step.

1.3.2 - Drying Time (manual) or Dryness Level (auto)

In this next selection, the computer needs to know either the drying time or the dryness level. In the case of the manual drying mode the dryer offers the possibility of 0 to 99 minutes of drying time in one-minute increments or 90 to 100 percent dry for the automatic drying mode in one-percent increments.

When the computer displays either the “Dry Time= __Min” or “Dry Level= __%” messages, enter the selection of your choice from the ranges shown above and validate it by pressing the enter key. Once the value is validated, the computer will advance to the next selection.

1.3.3 Drying Sensor (intake or exhaust)

This selection will specify to the computer which temperature sensor will be used for the particular preprogrammed cycle the user is configuring. The dryer offers the option of drying from intake or exhaust temperatures. When the computer displays the message “Sens In=1 / Ex=0 __,” enter the selection of your choice by placing a “1” or a “0” in the blinking field of the message. Again, validate your selection by pressing the enter key. The computer will save your selection in memory and advance to the next needed selection.

1.3.4 Drying Temperature

During this selection the computer will prompt the operator for a drying temperature. This will vary in available range as a function of the drying mode and temperature sensor specified in the previous step. The dryer offers the following drying temperature ranges for the available drying modes and sensors:

Manual Mode	Automatic Mode
Exhaust: 100 to 210 F (38 to 99°C)	Exhaust: 160 to 210 F (70 to 99°C)

All temperatures can be adjusted within these ranges in 1 degree increments.

When the computer displays the message “Dry Temp __F or C,” enter the temperature set point of your choice and validate it by pressing the enter key. Upon validation, the computer will store the value and advance to the next selection.

1.3.5 Cool Down Time

This next selection pertains to the amount of time allowed for cool down for the specific cycle being programmed. The dryer will allow cool down for the specific cycle being programmed. The dryer will allow cool down times ranging from 0 to 9 minutes in one-minute increments.

When the computer displays the message "Cool Time= __ Min," enter the amount of time of your choice from the range outlined above and validate it by pressing the enter key. The computer will store the value and advance to the last operating selection available in this mode.

1.3.6 Reversing or Non-Reversing Cycle

This last operating selection completes the information needed to program a given cycle and pertains to the ability that the dryer has of effecting a drying cycle in both the reversing or non-reversing modes of operation.

When the computer displays the message "Rev=0/Nrev=1 __," enter either a "1" or a "0" for reversing or non-reversing cycles, respectively. Upon placing the selection of your choice in the blinking field of the message, validate it by pressing the enter key.

1.3.7 Programming More Automatic Start Keys

At this point, the computer will save the information just fed to it and ask the user if he / she wishes to program more keys by displaying the message "Next A-F Key ?" The user can proceed to program more keys by pressing the keypad key called "Next," and the computer will ask the operator to press the next key from "A" through "F" by displaying the message "Press A-F Key," at which point the programming process will be repeated. If no more keys need to be programmed, the user may return to the run mode by pressing the stop keypad, at which point the computer will display the message "***AD-###**" and be ready to execute a given cycle.

SECTION VI

DIAGNOSTICS, MESSAGES, AND INPUT / OUTPUT INDICATORS

The dryer's control system contains among its features a complete set of dryer diagnostics which are continuously scanning all major operational and safety components. Parameters scanned include: gas pressure, motors, airflow, high-limit thermostats, doors, sensors, etc. Should the control system detect an abnormal or unsafe condition in the dryer, depending on potential hazardousness, it will take specific actions. The terminal display, will give an indication as to what the problem area might be.

1.0 Display Messages

Following is a list of all the diagnostic messages used throughout this helpful feature.

Message	Description	Remarks
CNTRL VOLT OFF	Control Voltage Off	110 VAC
INTAKE DSFL	Intake Drying Sensor Fault	—
EXHAUST DSFL	Exhaust Drying Sensor Fault	—
DOOR OPEN	Front, Rear, or Burner Door Open	—
CHK.LINT DRAWER	Lint Screen Fault	—
MOTOR FAULT	Motor Overload Tripped	Any Motor
GAS SUPPLY FAULT	Gas Pressure Fault	High or Low
AIR FLOW FAULT	Air Flow Fault	Main Fan
HEATER FAULT	Heater Fault	Burner or Steam
HI-TEMP FAULT	High-Temp Switch Fault	Exhaust, Burner or Drum
DRUM FAULT	Drum Rotation Fault	—
LEVEL FAULT	Level Fault	Front or Rear
LINE FAULT	Terminal to PLC Interface	—

Note: The above messages are listed for the convenience of the user only.

For troubleshooting, refer to the installation manual.

2.0 Input and Output Indicators

To further enhance the diagnostic features of the system the dryer controls also contain L.E.D. indicators for most computer inputs and outputs utilized by the system at any given time. These indicators reside inside of the front electric cabinet on the computer itself and are all numbered for ease of identification, (see illustration on page 20).

The following list identifies all the inputs and outputs used by the system.

Input	Function	Output	Function
0,0	Control Voltage	0,0	Main Fan Motor
0,1	Motor Fault	0,1	Drum Forward
0,2	Heater Fault	0,2	Drum Reverse
0,3	Hi-Temp Fault	0,3	--
0,4	Gas Fault	0,4	Heat, On-Off
0,5	Air Flow Fault	0,5	Heat, Hi-Lo
0,6	Front Door	0,6	Load Door, Open
0,7	Rear Door	0,7	Load Door, Close
0,8	Lint Drawer	0,8	Unload Door, Open
0,9	Burner Doors	0,9	Unload Door, Close
0,10	Drum Rotation	0,10	Front Up
0,11	Front Down	0,11	Front Down
0,12	Rear Down	1,0	Rear Up
0,13	Exhaust / Reclaim	1,1	Rear Down
0,14	Main Valve or Damper	1,2	Exhaust Air
0,15	Load, Pendant	1,3	Recirculate Air
0,16	Unload, Pendant	1,4	Tone, End of Cycle
0,17	Jog FWD, Pendant	1,5	Strobe, End of Cycle
0,18	Jog REV, Pendant	--	--
0,19	Unload, Rear Panel	--	--
0,20	Jog FWD, Rear Panel	--	--
0,21	Jog REV, Rear Panel	--	--

Nomenclature: The table above identifies the input or output numbers and the system signals or functions associated with each one of them.

Inputs 0,0 to 0,21 are associated with L.E.D.s 0 to 21.

Outputs 0,0 to 1,5 are associated with L.E.D.s 0 to 11 on the main rack, and 0 to 5 on the second rack, (see illustration on next page).

3.0 Other Indicators

In addition to the input/output indicators, the dryer's computer also has other PLC status indicators. These status indicators are located on the main rack right side adjacent to the large input/output red L.E.D. screen. This next list depicts these other annunciators, their location and function, (see illustration below).

PLC Status Display

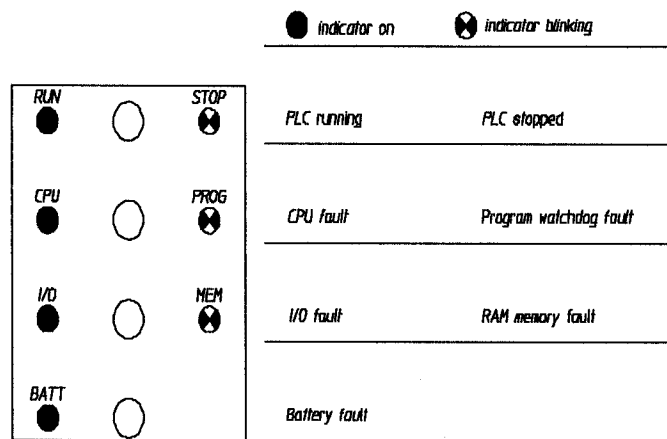

MAN2743

The status of these indicators are a result of the PLC internal diagnostic feature that runs continuously by the computer.

SECTION VII

BATTERY BACK-UP

The dryer's computer uses a lithium battery to supply power to retain memory should power interruptions occur. It is suggested that the battery be replaced once a year or as found necessary. The battery life will depend on the age of the battery, the number of power interruptions, and back-up time used.

Important: For proper operation, replace only with identical lithium battery.

1.0 INSTALLING THE BATTERY

1.1 Turn the input electrical power to the dryer off.

1.2 Open the electric cabinet door.

1.3 Locate the computer battery compartment door.
(see illustration on side)

1.4 Release the battery compartment cover.

1.5 Remove the cover.

1.6 Fit the new battery.

1.7 Plug in the battery.

1.8 Reinstall the cover.

1.9 Push down to lock cover in place.

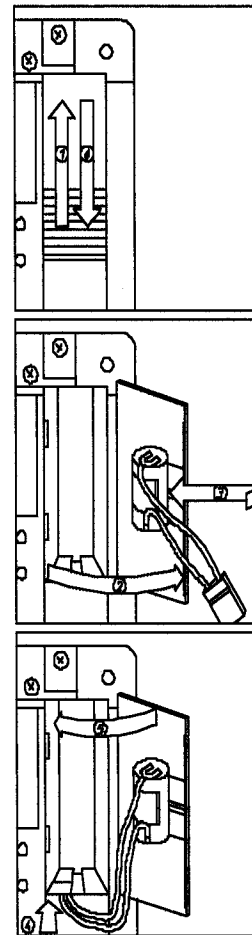

MAN276B

SECTION VIII

LANGUAGE AND MEMORY CARTRIDGE REPLACEMENTS

1.0 INSTALLING A MODULE

1.1 Turn the input electrical power to the dryer off.

1.2 Open the electric cabinet door.

1.3 Locate the cartridge in need of replacement
(see illustration on the side)

1.4 Release the cartridge compartment cover.

1.5 Pull the cartridge cover to remove module.

1.6 Verify cartridge is in Master (Read only) mode

1.7 Plug in the cartridge.

1.8 Turn power to dryer on and after 15 seconds
power dryer down.

1.9 Once again turn power to dryer on software is
now loaded in TSX.

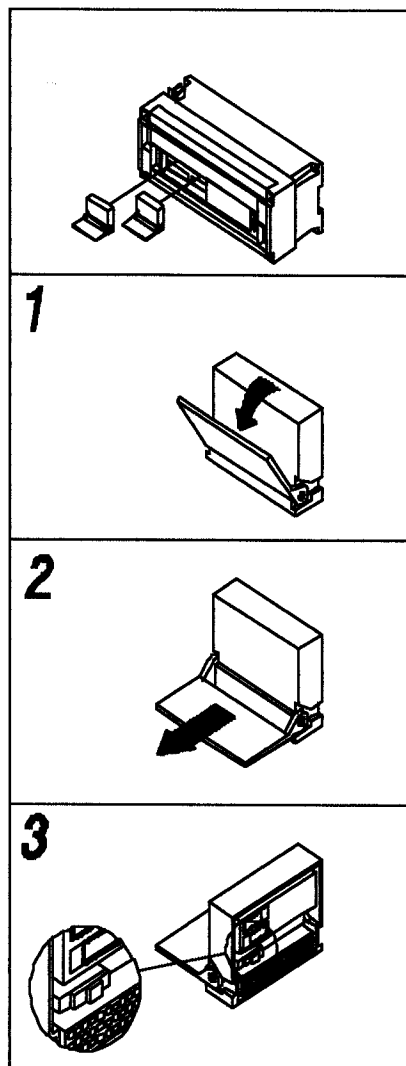

MAN2800

SECTION IX

FACTORY PRESET PROGRAMS

CYCLE	DRY MODE	DRYLVL	DRY TIME	DRY TEMP	COOL TIME	REV / NREV
A	Auto	100 %	—	210 F / 99 C	5 min	REV
B	Manual	—	30 min	210 F / 99 C	5 min	REV
C	Auto	95 %	—	190 F / 88 C	3 min	REV
D	Man	—	20 min	190 F / 88 C	3 min	REV
E	Auto	90 %	—	180 F / 82 C	2 min	REV
F	Manual	—	10 min	180 F / 88 C	2 min	REV

SYSTEM PARAMETERS:

1.0 Loading position: Tilted

2.0 Unloading point: Rear

3.0 Spin time: 60 sec.

4.0 Dwell time: 5 sec.

SECTION X

PROGRAMMING LIMITS

1.0 Preprogrammed Cycles

1.1 Automatic Drying Mode

1.1.1 Drying temperature: 160 to 210 F (20 to 99°C) in one degree increments.

1.1.2 Dryness level: 90 to 100 % in one-percent increments.

1.1.3 Cool down time: 0 to 9 minutes in one-minute increments.

1.2 Manual Drying Mode

1.2.1 Drying Temperature: 100 to 210 F (38 to 90°C) in one-degree increments.

1.2.2 Drying time: 0 to 99 minutes in one-minute increments.

1.2.3 Cool down time: 0 to 9 minutes in one-minute increments.

2.0 System Parameters

2.1 Spin time: 1 to 99 seconds in one-second increments.

2.2 Dwell time: 4 to 9 seconds in one-second increments.

3.0 Fixed Parameters

3.1 Guard delay time: 1 minute

3.2 Guard on time: 90 seconds

3.4 Maximum guard time: 30 minutes

3.5 Buzzer time: 8 seconds

3.6 Flash display temp / time: 3 seconds

SECTION XI

REPLACEMENT PARTS-LIST

Important: When ordering replacement parts from your distributor or the factory, specify the dryer model number and serial number in addition to the part description and part number so that your order is processed accurately and promptly.

Note: In the following illustrations, be sure to check the descriptions thoroughly before ordering.

Refer to the specific parts manual for your dryer when ordering replacement parts.

SECTION XII

APPENDIX

1. PLC Display Terminal

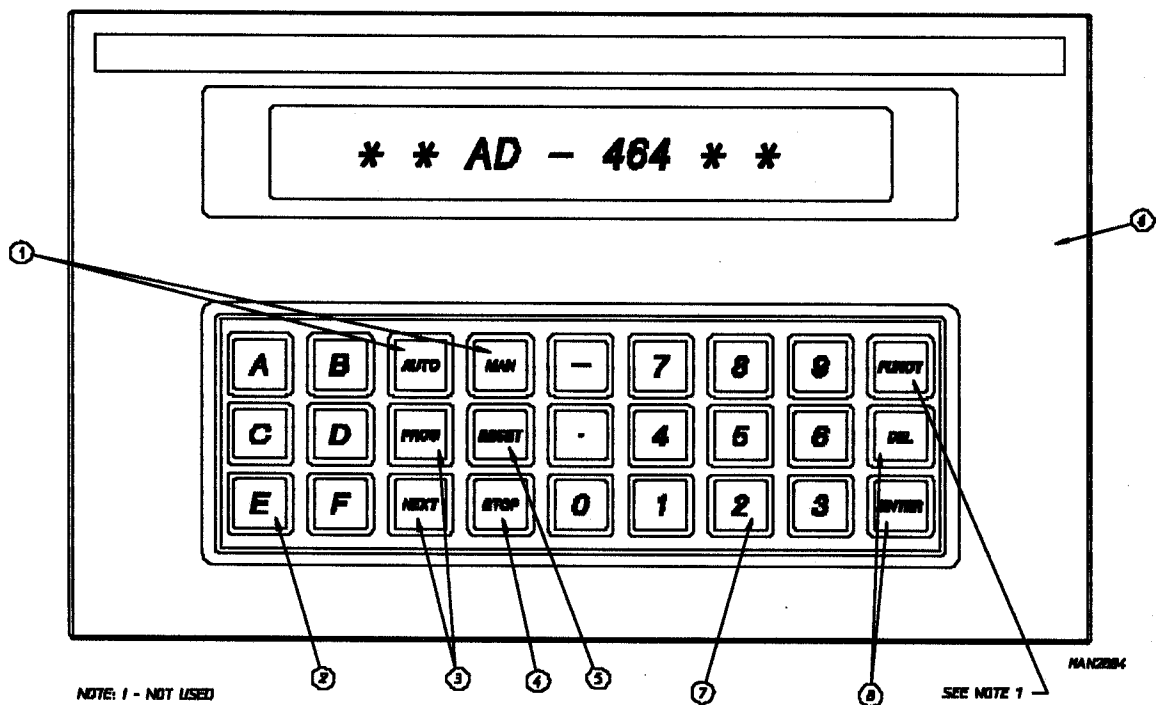

1. Manually Input Cycles, Manual / Auto
2. One-Key Start, "A" through "F" Keys
3. Program Mode Keys, Prog/Next
4. Stop Key
5. Reset Key
6. Zinc Alloy Face Plate
7. Numeric Keys
8. Editing Keys, Enter / Delete

2. Micro-PLC

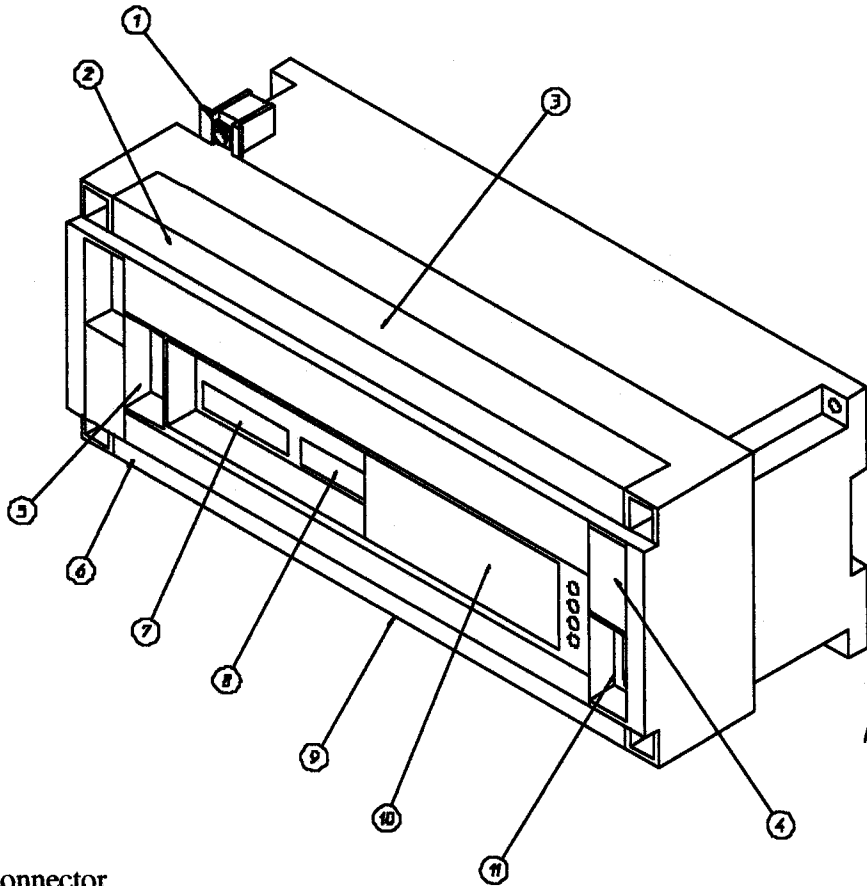

1. Ground connector
2. Relay outputs
3. Removable terminal blocks with captive screw terminals (outputs)
4. Battery location
5. Terminal connector port
6. 110 VAC input supply terminal
7. Location for language software cartridge
8. Location for plug-in memory cartridge
9. Removable terminal blocks with captive screw terminals (inputs)
10. Front panel status display.
11. 9-Pin I/O bus extension connector

3. Analog Input Module

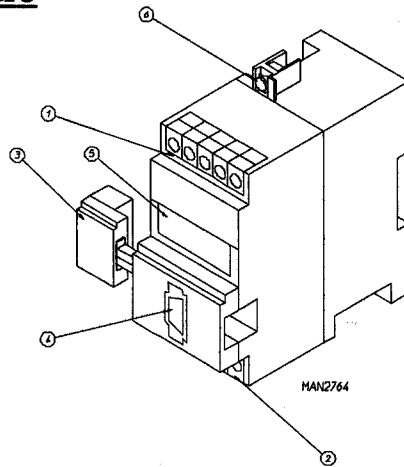

1. Analog inputs
2. Analog inputs
3. 9-Pin I/O bus input connector and its cable
4. 9-Pin I/O bus output connector and its cable
5. Front panel status display
6. Ground connector

4. Output Module

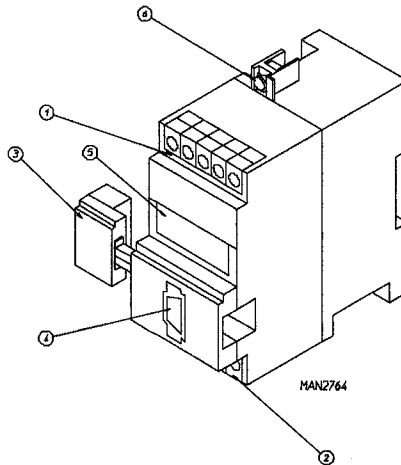

1. Relay outputs
2. Relay outputs
3. 9-Pin I/O bus input connector and its cable
4. 9-Pin I/O bus output connector and its cable
5. Front panel status display
6. Ground connector

5. Lithium Battery

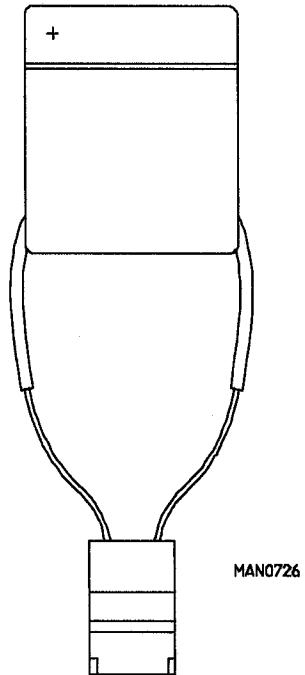

6. RS232 Cable

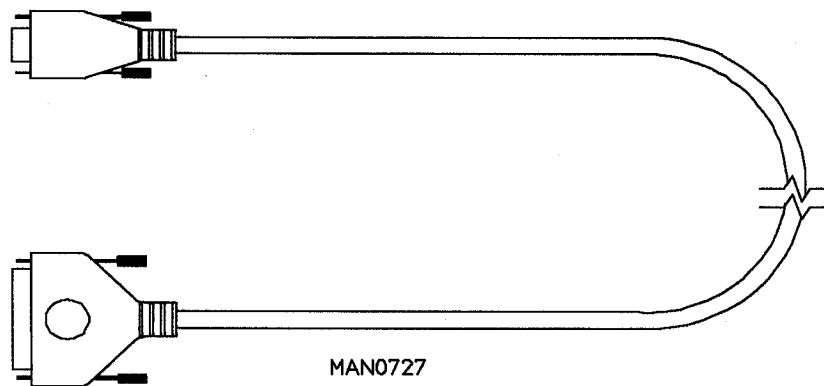

7. Bus Terminator

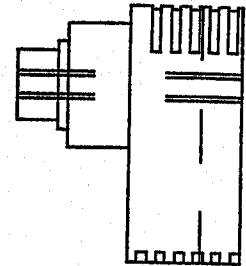
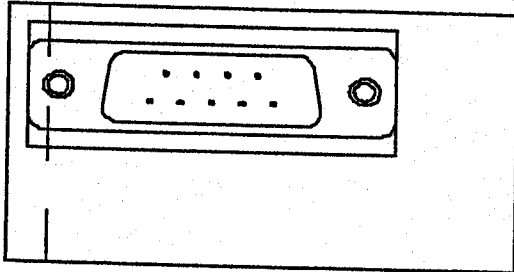

MAN2767

8. Language and Memory Cartridges

Items 7 and 8

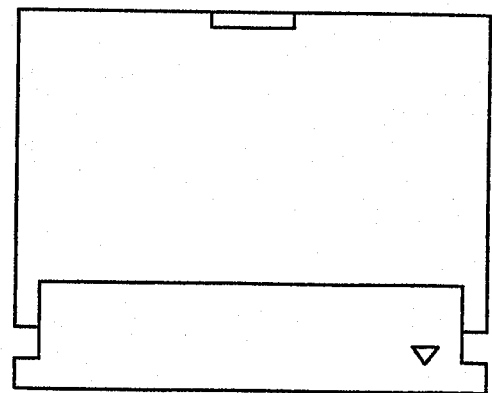
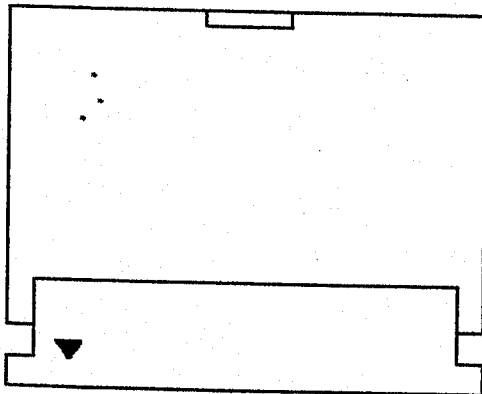

MAN2762

Cartridges should be inserted when the PLC is powered-down.

ADC112199

1- 01/13/97-7
4- 01/19/00-20

2- 08/13/99-10
5- 09/29/00-20

3- 12/30/99-10
6- 06/11/01-20

