



SUPER AD-50 Parts Manual

24 VAC

1994 thru 2001

**MODELS: ADG-50DS
ADE-50S
ADS-50S**

American Dryer Corporation
88 Currant Road
Fall River, MA 02720-4781
Telephone: (508) 678-9000 / Fax: (508) 678-9447
E-mail: techsupport@amdry.com
www.adclaundry.com

Retain This Manual In A Safe Place For Future Reference

American Dryer Corporation products embody advanced concepts in engineering, design, and safety. If this product is properly maintained, it will provide many years of safe, efficient, and trouble-free operation.

ONLY qualified technicians should service this equipment.

OBSERVE ALL SAFETY PRECAUTIONS displayed on the equipment or specified in the installation manual included with the dryer.

The following “**FOR YOUR SAFETY**” caution **must be** posted near the dryer in a prominent location.

FOR YOUR SAFETY

Do not store or use gasoline or other flammable vapors and liquids in the vicinity of this or any other appliance.

POUR VOTRE SÉCURITÉ

Ne pas entreposer ni utiliser d'essence ni d'autres vapeurs ou liquides inflammables dans le voisinage de cet appareil ou de tout autre appareil.

We have tried to make this manual as complete as possible and hope you will find it useful. **ADC** reserves the right to make changes from time to time, without notice or obligation, in prices, specifications, colors, and material, and to change or discontinue models.

Important

For your convenience, log the following information:

DATE OF PURCHASE _____ **MODEL NO.** **SUPER AD-50**

RESELLER'S NAME _____

Serial Number(s) _____

Replacement parts can be obtained from your reseller or the **ADC** factory. When ordering replacement parts from the factory, you can FAX your order to **ADC** at (508) 678-9447 or telephone your order directly to the **ADC** Parts Department at (508) 678-9000. Please specify the dryer **model number** and **serial number** in addition to the **description** and **part number**, so that your order is processed accurately and promptly.

The illustrations on the following pages may not depict your particular dryer exactly. The illustrations are a composite of the various dryer models. Be sure to check the descriptions of the parts thoroughly before ordering.

“IMPORTANT NOTE TO PURCHASER”

Information **must be** obtained from your local gas supplier on the instructions to be followed if the user smells gas. These instructions **must be** posted in a prominent location near the dryer.

Table of Contents

Control Door Assembly Without Trim	
For Non-Coin Models Mfd. as of July 13, 1998	3
High Security Control Door Assembly	
For All Coin Models and Non-Coin Models Mfd. prior to July 13, 1998	4
Phase 5 Coin Microprocessor Control Panel Assembly	5
Phase 5 Non-Coin Microprocessor Control Panel Assembly	6
Phase 5 Coin and Non-Coin Microprocessor Control Box Assembly	7
Dual Timer “Tap Touch” Controls	
For Models Mfd. as of November 3, 2000	8
Dual Timer Control Panel Assembly	
For Models Mfd. prior to November 3, 2000	9
Dual Timer Control Box Assembly	10
Non-Microprocessor Coin Meter Control Panel Assembly	11
Non-Microprocessor Coin Meter Control Box Assembly	12
Coin Meter Replacement Parts	13
Coin Vault Assembly	14
“Plastic” Main Door Assembly	15
Main Door Switch Assembly For “Plastic” Door	16
Front Panel Assembly For “Plastic” Door	17
Main Door “Steel” Assembly	18
Main Door Switch Assembly Cold Rolled Steel Door	19
Cold Rolled Steel Door Front Panel	20
Lint Trap Assembly	21
Drop Lint Door Assembly Without Trim	
For Non-Coin Models Mfd. as of July 13, 1998	22
Drop Lint Door Assembly With Trim	
For All Coin Models and Non-Coin Models Mfd. prior to July 13, 1998	23

Tumbler / Support Assemblies	24
Idler Bearing Assembly	25
Tumbler Bearing Assembly	26, 27
Non-Reversing Totally Enclosed, Fan-Cooled Motor Mount Assembly	28, 29
Reversing Totally Enclosed, Fan-Cooled Motor Mount Assembly	30, 31
Sensor Bracket Assemblies	32, 33
Direct Spark Ignition Burner Assembly	34, 35
Electric Oven Assembly	36, 37
Steam Coil / Air Operated Steam Damper Assembly	38, 39
Sail Switch / Hi-Limit Assembly	40
Single-Phase (1Ø) Motor, Electric Relay Panel Assembly	41
3-Phase (3Ø) Motor, Electric Relay Panel Assembly	42
Microprocessor Reversing Rear Control Box Assembly	43
Dual Timer Reversing Rear Control Box Assembly	44
Outer Top / Back Guard Assemblies	45
Electric Oven Chart	46
Transformer Listing Gas / Steam Dryers	47
Transformer Usage Listing For Electric Dryers	48
Microprocessor Coin Acceptors Listing	49
Additional Parts Available	50

Control Door Assembly Without Trim

For Non-Coin Models Mfd. as of July 13, 1998

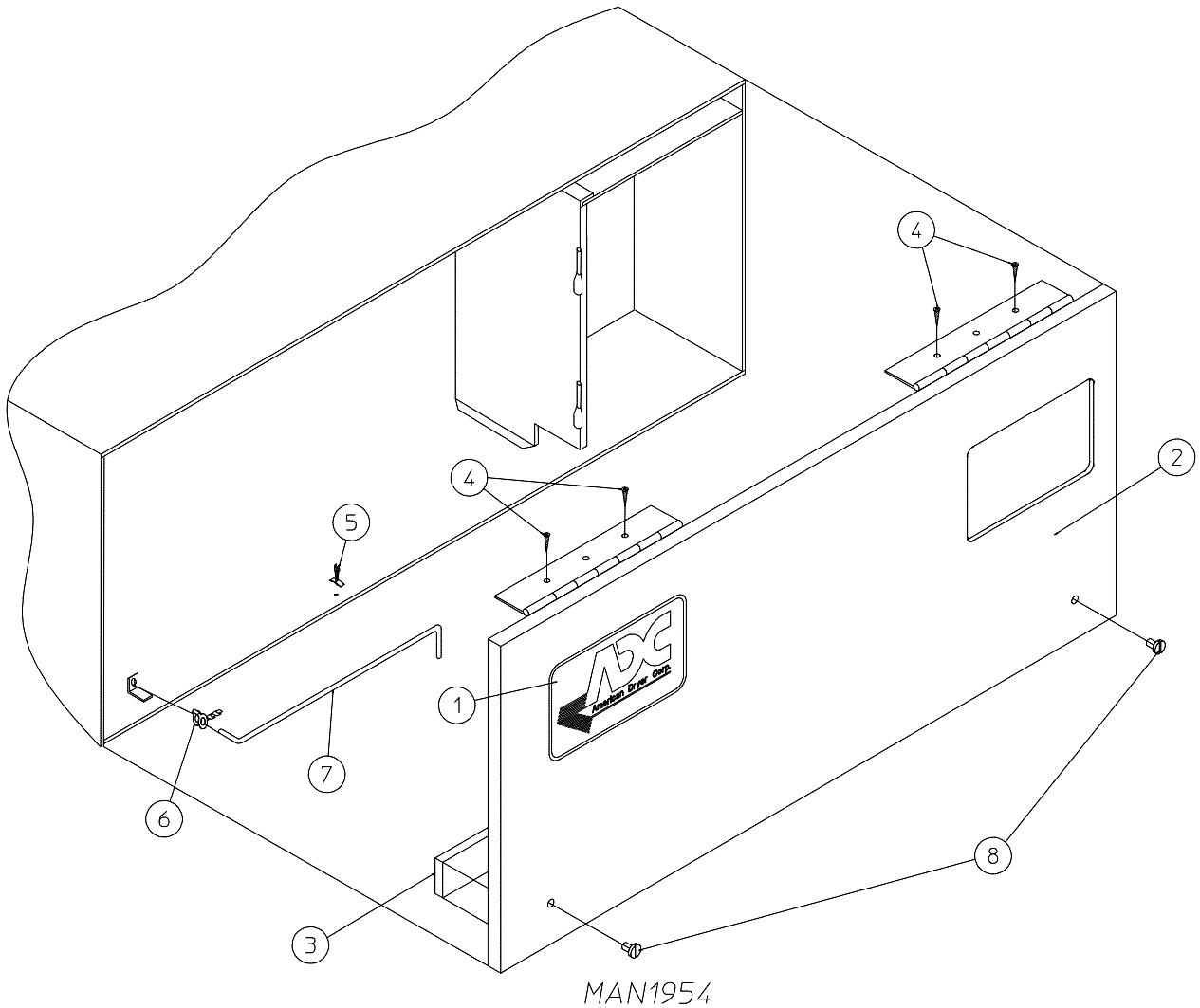

<u>Illus. No.</u>	<u>Part No.</u>	<u>Qty.</u>	<u>Description</u>
1	881053	1	ADC Logo Only (with double adhesive tape)
	870011	1	Logo Double Tape Kit
2	882265*	1	Control Door (includes illus. nos. 2 and 3)
3	117604	4	Neoprene Sponge Tape (sold by the foot)
4	150300	4	#10 x 1/2" Hex Washer TEK Screw
5	102603	1	Control Door Rod Support Catch
6	102601	1	Control Door Retainer Clip
7	102502	1	Control Door Support Rod
8	882541	2	Spring Turn Latch Assembly

* Specify color when ordering.

High Security Control Door Assembly

For ALL Coin Models and Non-Coin Models Mfd. prior to July 13, 1998

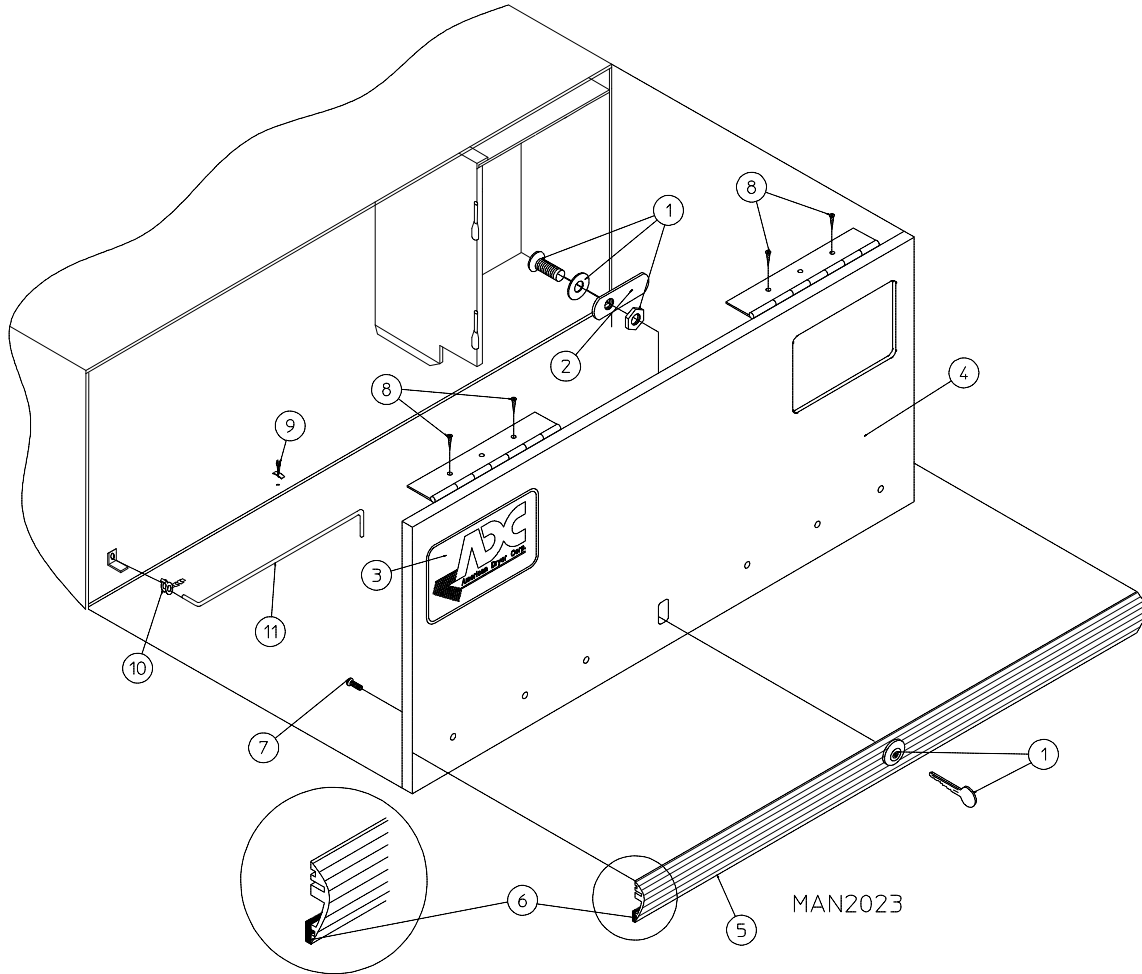

<u>Illus. No.</u>	<u>Part No.</u>	<u>Qty.</u>	<u>Description</u>
1	160015	1	High Security MK-100 Lock Assembly with Key (for coin models Only)
	160104	1	MK-100 Key Only
	160017	1	Special Dummy Lock Only (for non-coin models Only)
2	160032	1	Lock Cam Only
	881053	1	ADC Logo with Tape Kit
3	112350	1	ADC Logo Only
	870011	1	Double Sided Tape Kit
	800022	1	High Security Control Door Assembly Less Lock (includes illus. nos. 4 through 7)
4*	800141	1	High Security Stainless Steel Control Door Assembly Less Lock (includes illus. nos. 4 through 7)
5	180201	1	Top Trim with Lock Hole
6	117603	3	Suppressor Tape / Gasket (sold by the foot)
7	150201	5	#10-32 x 1/4" Phillips Round Head Machine Screw
8	150300	4	#10 x 1/2" Hex Washer TEK Screw
9	102603	1	Control Door Support Rod Catch
10	102601	1	Control Door Rod Retainer Clip
11	102502	1	Control Door Support Rod

* Specify color when ordering.

Phase 5 Coin Microprocessor Control Panel Assembly

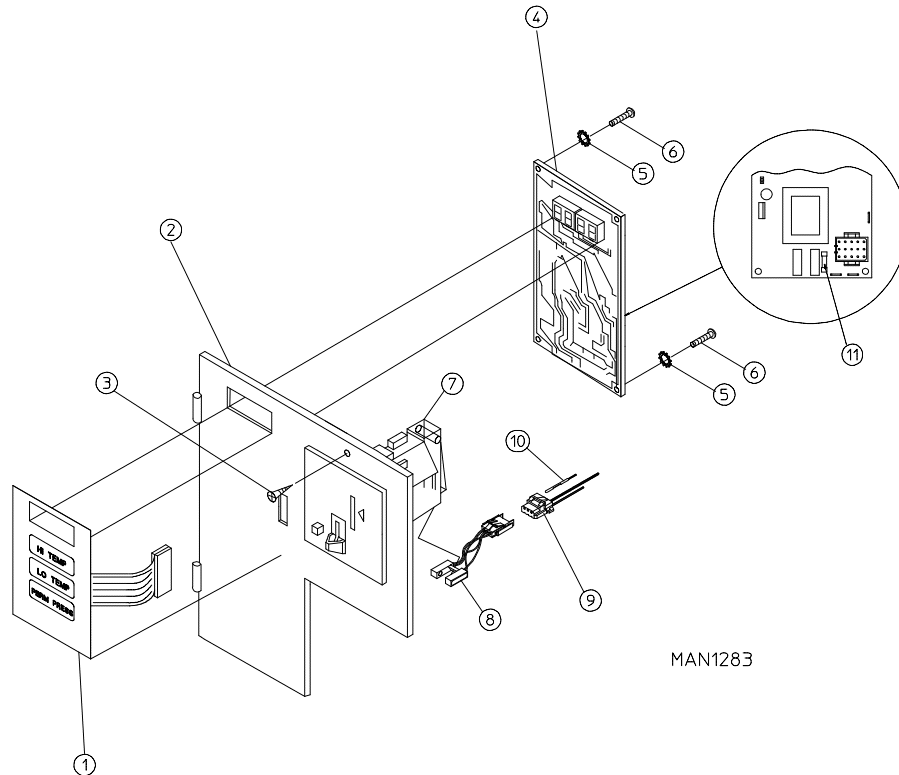

MAN1283

<u>Illus. No.</u>	<u>Part No.</u>	<u>Qty.</u>	<u>Description</u>
1	112526	1	Coin Keyboard Label Assembly
2	801213	1	Phase 5 Coin Control Panel Assembly (includes illus. nos. 1, 2, 4 through 6 and 11)
	801229	1	Phase 5 Coin Control Panel Assembly with Battery Option (includes illus. nos. 1, 2, 4 through 6 and 11)
	801259	1	Coin Control Panel Only
	801258	1	Coin Control Panel with Battery Bracket
3	150309	1	#10-16 x 1/2" Hex Head TEK Crimpite Screw
4	137213	1	Phase 5 Coin Controller Only
	824998	1	Phase 5 Battery Clip
5	153010	2	#6 Star Washer
6	150005	2	#6-32 x 1/4" Phillips Round Head Machine Screw
7	-----	1	Microprocessor Coin Acceptor with Optical Switch (refer to Microprocessor Coin Acceptors Listing on page 49)
8	137056	1*	Optic Switch Only (Greenwald coin acceptors)
	881143	1*	Optic Switch Only (Hanke coin acceptors)
9	137023	1*	Optic Switch Connector Only
10	137021	3*	Microprocessor Socket Only
	880772	1	Single Coin Optical Switch Harness
	824080	1	Dual Coin Optical Switch Harness
	122800	1	Microprocessor (female) Pin Extraction Tool
11	136048	1	1/8-Amp (Slo-Blo) Fuse

* For dual coin models, double the quantity.

IMPORTANT: Check label on computer chip to verify correct part number for controller.

Phase 5 Non-Coin Microprocessor Control Panel Assembly

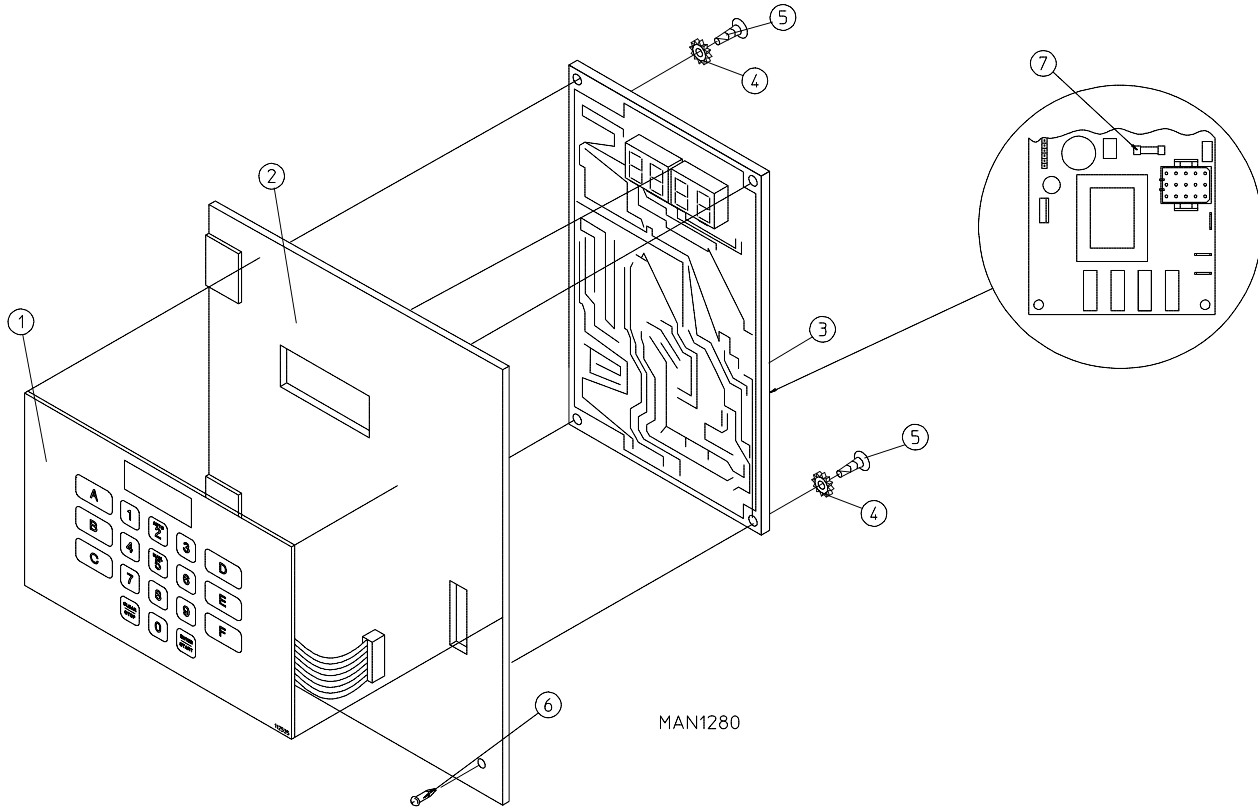

<u>Illus. No.</u>	<u>Part No.</u>	<u>Qty.</u>	<u>Description</u>
1	112535	1	Non-Coin English Keyboard Label Assembly
	112276	1	Non-Coin Stick-On Labels (English Only)...Not Illustrated
	112275	1	3-Language Non-Coin Stick-On Labels...Not Illustrated (Spanish, Italian, and Hebrew)
	112277	1	3-Language Non-Coin Stick-On Labels...Not Illustrated (English, Spanish, and Hebrew)
	112278	1	5-Language Non-Coin Stick-On Labels...Not Illustrated (Italian, Dutch, French, German, and Chinese)
2	801255	1	Phase 5 Microprocessor Control Panel Only
	801256	1	Phase 5 Microprocessor Control Panel Only with Battery Bracket
	801206	1	Phase 5 Non-Coin Non-Reversing Microprocessor Control Panel Assembly Complete (includes illus. nos. 1 through 7)
	801207	1	Phase 5 Non-Coin Reversing Microprocessor Control Panel Assembly Complete (includes illus. nos. 1 through 7)
3	137222	1	Phase 5 Non-Coin Non-Reversing Controller Only
	137231	1	Phase 5 Non-Coin Reversing Controller Only
	824998	1	Phase 5 Battery Clip
4	153010	2	#6 Star Washer
5	150005	2	#6-32 x 3/4" Phillips Round Head Machine Screw
6	150309	1	#10-16 x 1/2" Hex Head TEK Crimptite Screw
7	136048	1	1/8-Amp (Slo-Blo) Fuse

IMPORTANT: Check label on computer chip to verify correct part number for controller.

Phase 5 Coin and Non-Coin Microprocessor Control Box Assembly

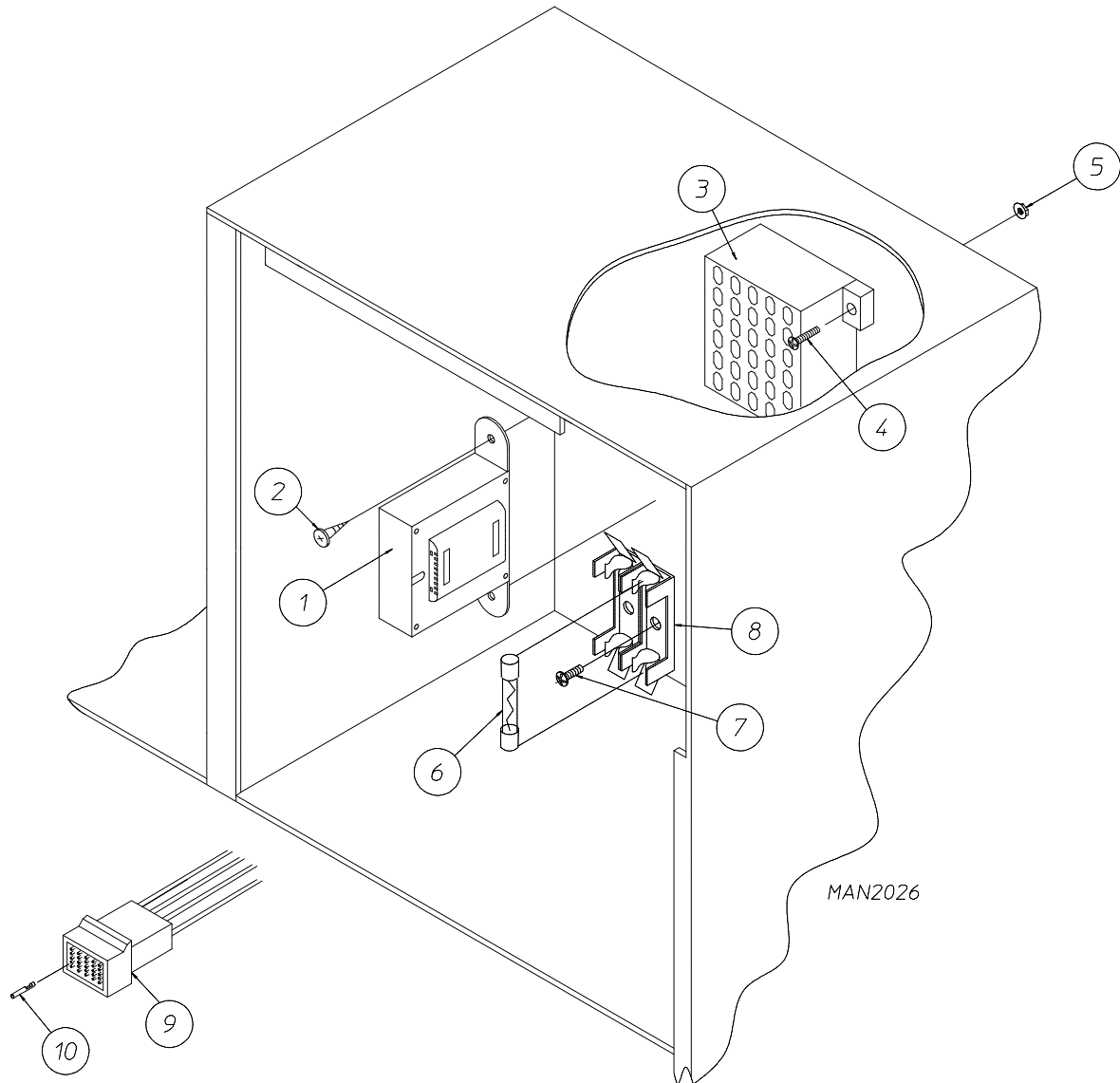

<u>Illus. No.</u>	<u>Part No.</u>	<u>Qty.</u>	<u>Description</u>
1	141403	1	24 VAC Transformer For ALL Gas and Steam Models, and Electric Models of 380/416/480 Volt
	132070	1	24 VAC Transformer (for electric models of 208 volt/240 volt)
2	150300	2	#10 x 1/2" Hex Washer TEK Screw
3	120715	1	30-Position Terminal Block
4	150002	2	#6-32 x 1" Phillips Round Head Machine Screw
5	151000	2	#6-32 Pal Nut
6	136057	*	1/2-Amp (Slo-Blo) Fuse
7	150301	*	#8-18 x 7/16" Phillips Pan Head TEK Screw
8	136008	*	Fuse Block/Strip Only
9	122641	1	15-Pin Microprocessor Connector
10	122706	*	Socket

* As required.

Dual Timer "Tap Touch" Controls

For Models Mfd. as of November 3, 2000

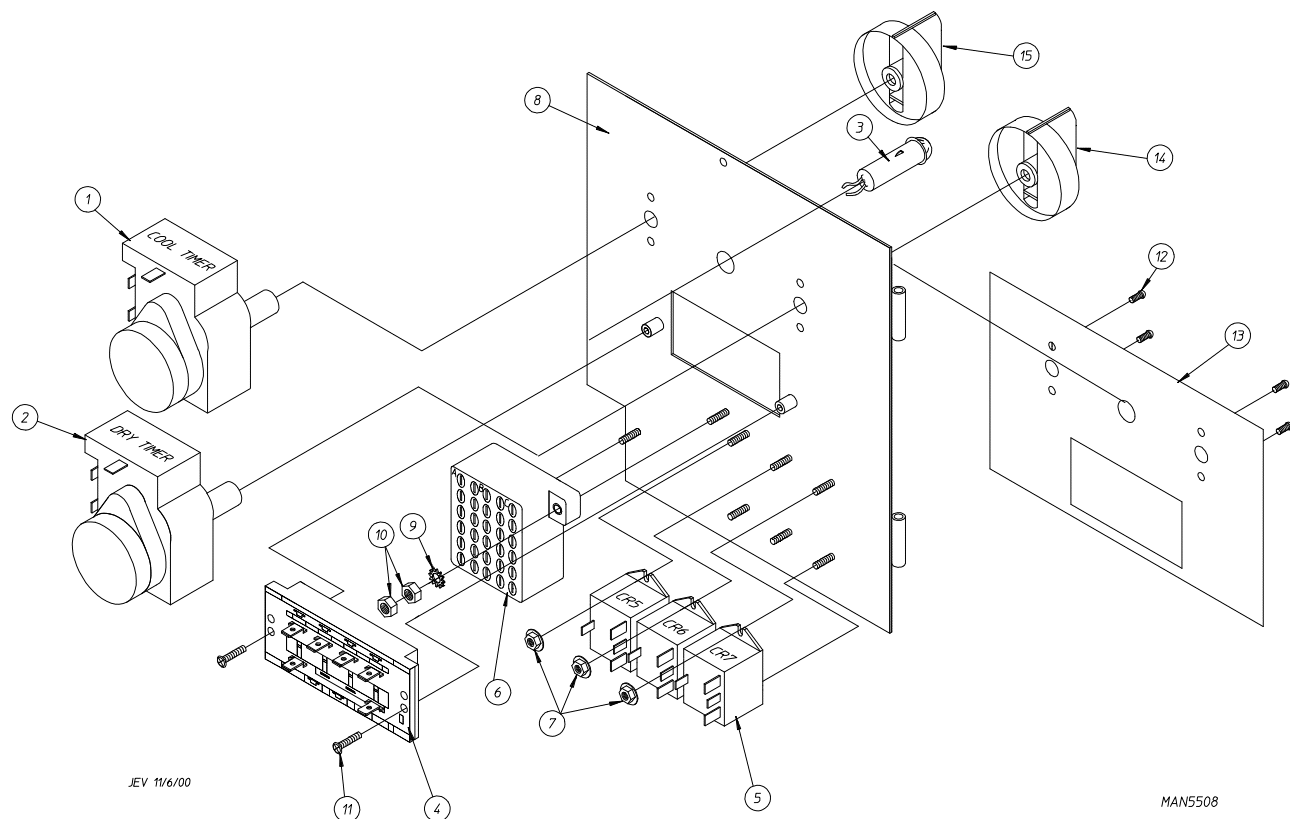

<u>Illus. No.</u>	<u>Part No.</u>	<u>Qty.</u>	<u>Description</u>
1	124030	1	15 Minute Timer – 24 VAC
2	124025	1	60 Minute Timer – 24 VAC
3	824175	1	Red Pilot Light – 24 VAC
4	122301	1	"Tap Touch" Switch
5	131932	3	Relay SPST 24v
6	120730	1	30-Position Terminal Block
7	151000	6	#6-32 Pal Nut
8	882903	1	Dual Timer Panel Complete (includes illus. nos. 1 through 15)
	850392	-	Dual Timer Panel Only
9	153010	2	#6 Star Washer
10	152000	3	#6-32 Hex Nut
11	150207	2	#10-24 x 1/2" Phillips Pan Head Machine Screw
12	150110	4	#8-32 x 1/4" Phillips Round Head Machine Screw
13	112563	1	Dual Timer Panel Overlay
14	124104	1	Pure Touch Knob with Red Pointer
15	124105	1	Pure Touch Knob with Blue Pointer

Dual Timer Control Panel Assembly

For Models Mfd. prior to November 3, 2000

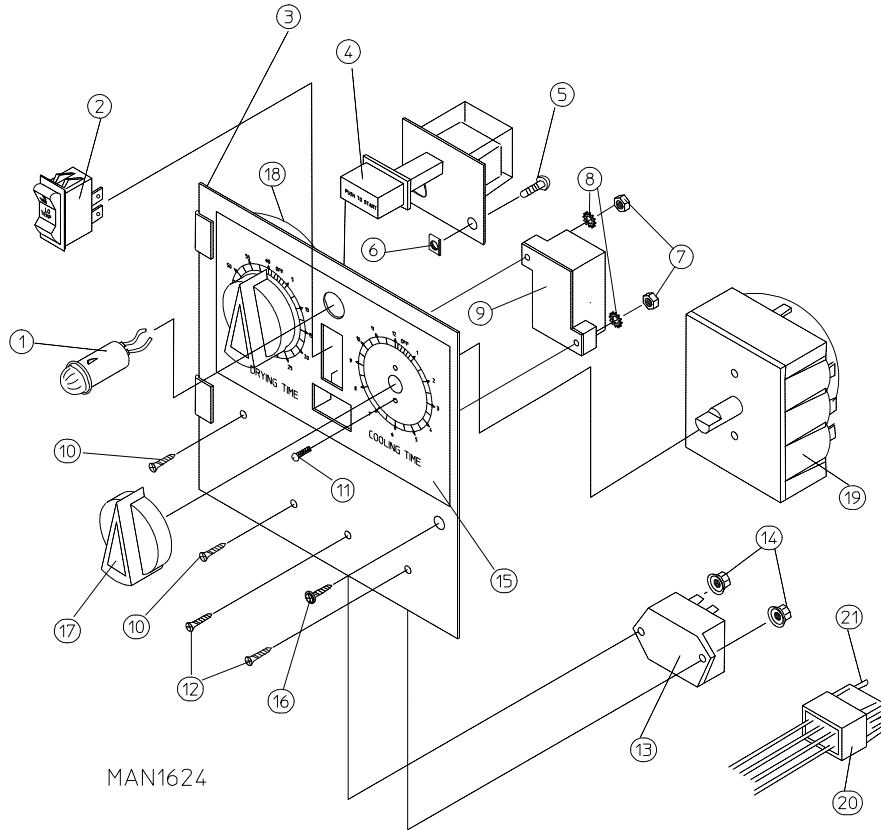

<u>Illus. No.</u>	<u>Part No.</u>	<u>Qty.</u>	<u>Description</u>
1	123005	1	Red Indicator Light – 24 VAC
2	122400	1	Rocker Heat Selector Switch
3	824015	1	Dual Timer Control Panel Assembly Complete – 24 VAC (includes illus. nos. 1 through 21)
	800051	1	Dual Timer Control Panel Only
4	131917	1	Push-to-Start Relay – 24 VAC
5	150207	2	#10-24 x 1/2" Round Head Machine Screw
6	154001	2	#10-24 Speed Nut
7	152000	2	#6-32 Hex Nut
8	153010	2	#6 Star Washer
9	120713	1	18-Position Terminal Block
10	150002	2	#6-32 x 1" Round Head Machine Screw
11	150110	4	#8-32 x 1/4" Phillips Machine Screw
12	150001	2	#6-32 x 1/2" Round Head Machine Screw
13	131931	1	Dual Timer Relay – 24 VAC
14	151000	2	#6-32 Pal Nut
15	112050	1	Dual Timer Label Only
16	150309	1	#10-16 x 1/2" Hex Head TEK Crimptite Screw
17	124103	2	Arrow Timer – 24 VAC
18	124025	1	60 Minute Timer – 24 VAC
19	124030	1	15 Minute Timer – 24 VAC
20	122602	1	9-Pin Connector Only
21	122700	8	Pin Terminal Only
--	122801	1	Pin / Socket Extraction Tool

Dual Timer Control Box Assembly

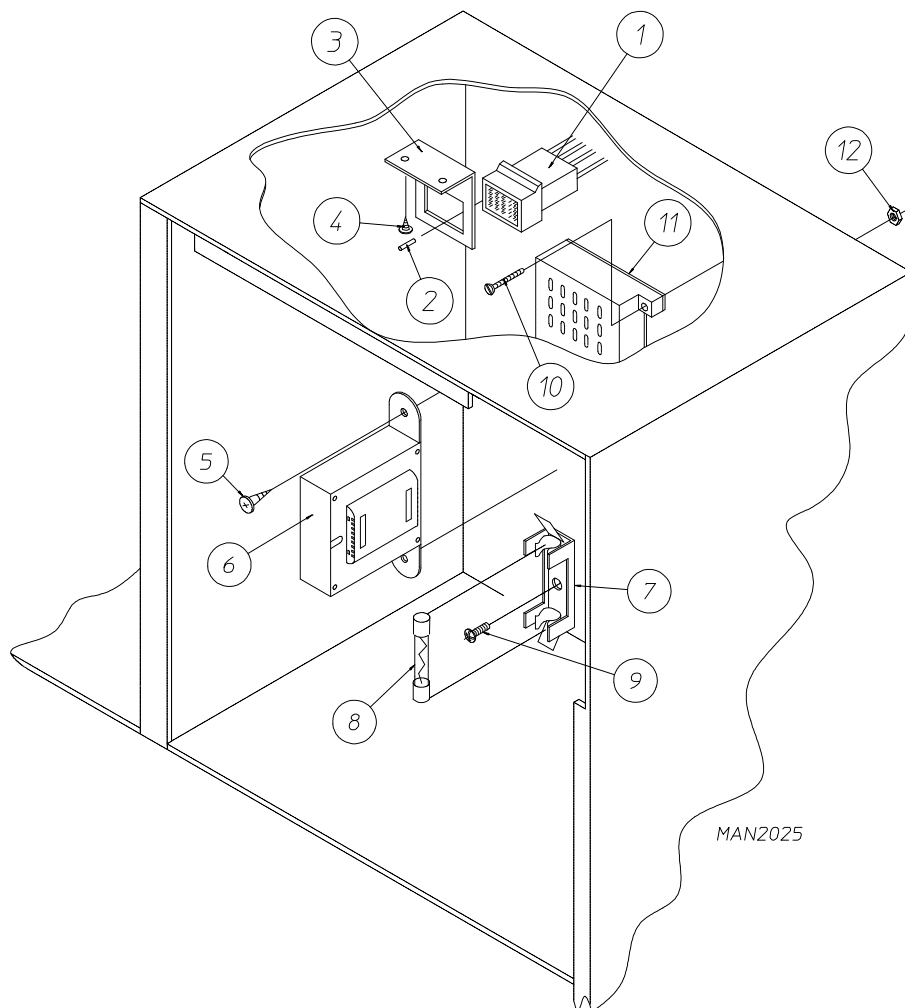

<u>Illus. No.</u>	<u>Part No.</u>	<u>Qty.</u>	<u>Description</u>
1	122603	1	9-Pin Socket Connector
2	122701	9	Socket Terminal Only
	122801	1	Pin / Socket Extraction Tool
3	315010	1	9-Pin Connector Bracket
4	150300	2	#10 x 1/2" Hex Washer TEK Screw
5	150300	2	#10 x 1/2" Hex Washer TEK Screw
6	141403	1	24 VAC Transformer
			(for ALL gas and steam models, and electric models of 380/416/480 volt)
	132070	1	24 VAC Transformer
			(for electric models of 208 volt/240 volt)
7	136008	*	Fuse Block/Strip Only
8**	136057	*	1/2-Amp (Slo-Blo) Fuse
9	150301	*	#8 x 7/16" Phillips Pan Head TEK Screw
10	150002	2	#6-32 x 1" Phillips Round Head Machine Screw
11	120715	1	30-Position Terminal Block
12	151000	2	#6-32 Pal Nut

* As required.

** Check fusing on dryer for verification.

Non-Microprocessor Coin Meter Control Panel Assembly

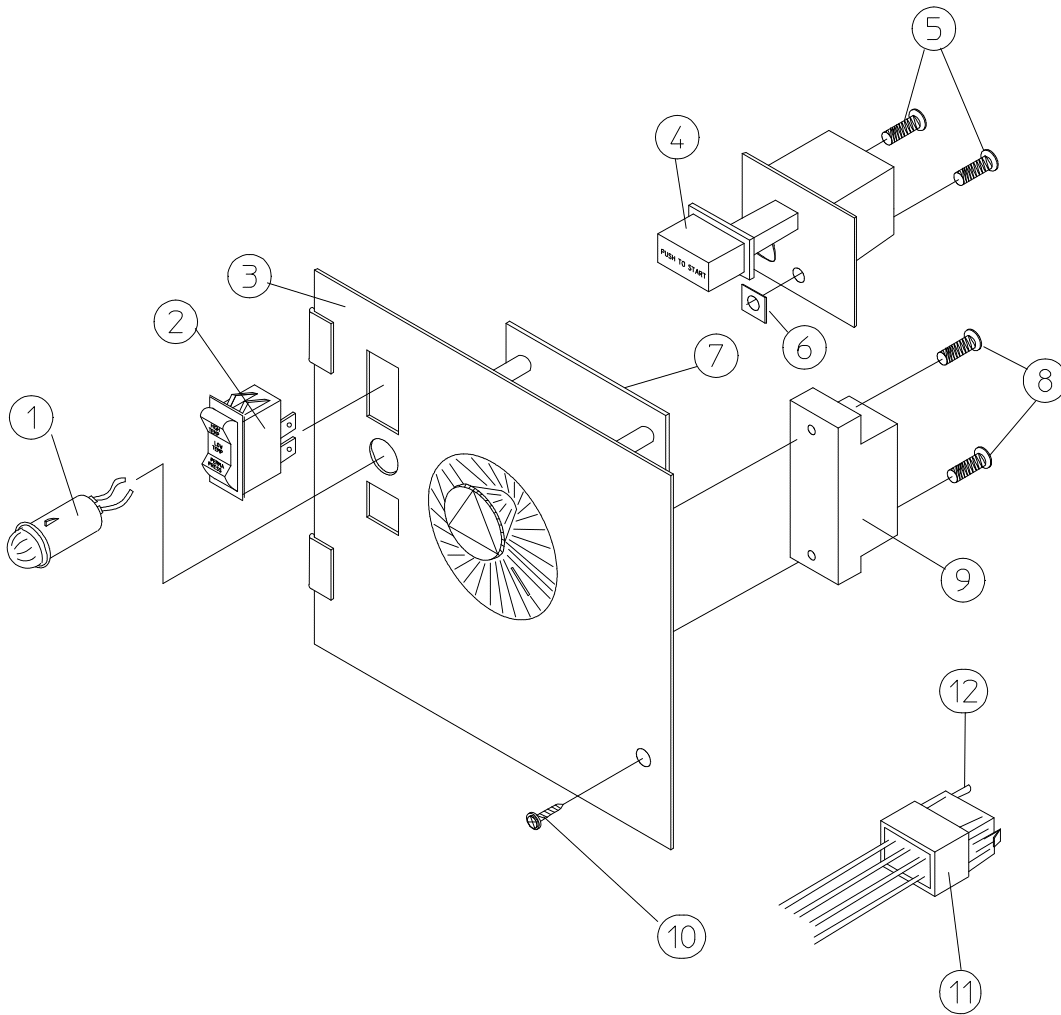

MAN1625

<u>Illus. No.</u>	<u>Part No.</u>	<u>Qty.</u>	<u>Description</u>
1	123005	1	Red Indicator Light – 24 VAC
2	122400	1	Rocker Heat Selector Switch
3	824020	1	Coin Meter Control Panel Assembly Complete – 24 VAC (includes illus. nos. 1 through 6 and 8 through 12)
	800054	1	Coin Meter Control Panel Only
4	131917	1	Push-to-Start Relay – 24 VAC
5	150207	2	#10-24 x 1/2" Round Head Machine Screw
6	154001	2	#10-24 Speed Nut
7*	125601	1	25¢ Coin Meter 24v (specify timing)
8	150303	2	#4 x 3/4" Pan Head "A" Screw
9	120712	1	12-Position Terminal Block
10	150309	1	#10-16 x 1/2" Hex Head TEK Crimptite Screw
11	122602	1	9-Pin Connector Only
12	122700	9	Pin Terminal Only
--	122801	1	Pin / Socket Extraction Tool

* Consult factory for coin meters not listed.

Non-Microprocessor Coin Meter Control Box Assembly

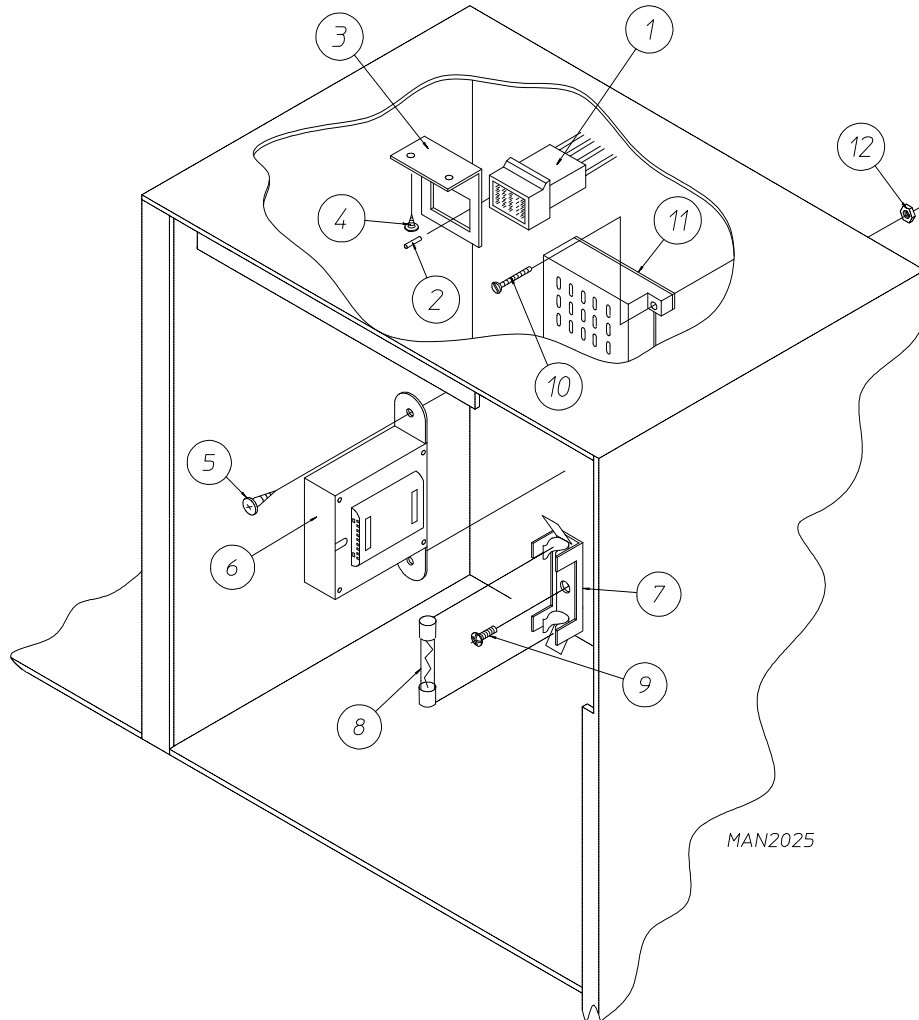

<u>Illus. No.</u>	<u>Part No.</u>	<u>Qty.</u>	<u>Description</u>
1	122603	1	9-Pin Socket Connector
2	122701	9	Socket Terminal Only
	122801	1	Pin / Socket Extraction Tool
3	315010	1	9-Pin Connector Bracket
4	150300	2	#10 x 1/2" Hex Washer TEK Screw
5	150300	2	#10 x 1/2" Hex Washer TEK Screw
6	141403	1	24 VAC Transformer
			(for ALL gas and steam models, and electric models of 380/416/480 volt)
	132070	1	24 VAC Transformer
			(for electric models of 208/240 volt)
7	136008	*	Fuse Block/Strip Only
8**	136057	*	1/2-Amp (Slo-Blo) Fuse
9	150301	*	#8 x 7/16" Phillips Pan Head TEK Screw
10	150002	2	#6-32 x 1" Phillips Round Head Machine Screw
11	120715	1	30-Position Terminal Block
12	151000	2	#6-32 Pal Nut

* As required.

** Check fusing on dryer for verification.

Coin Meter Replacement Parts

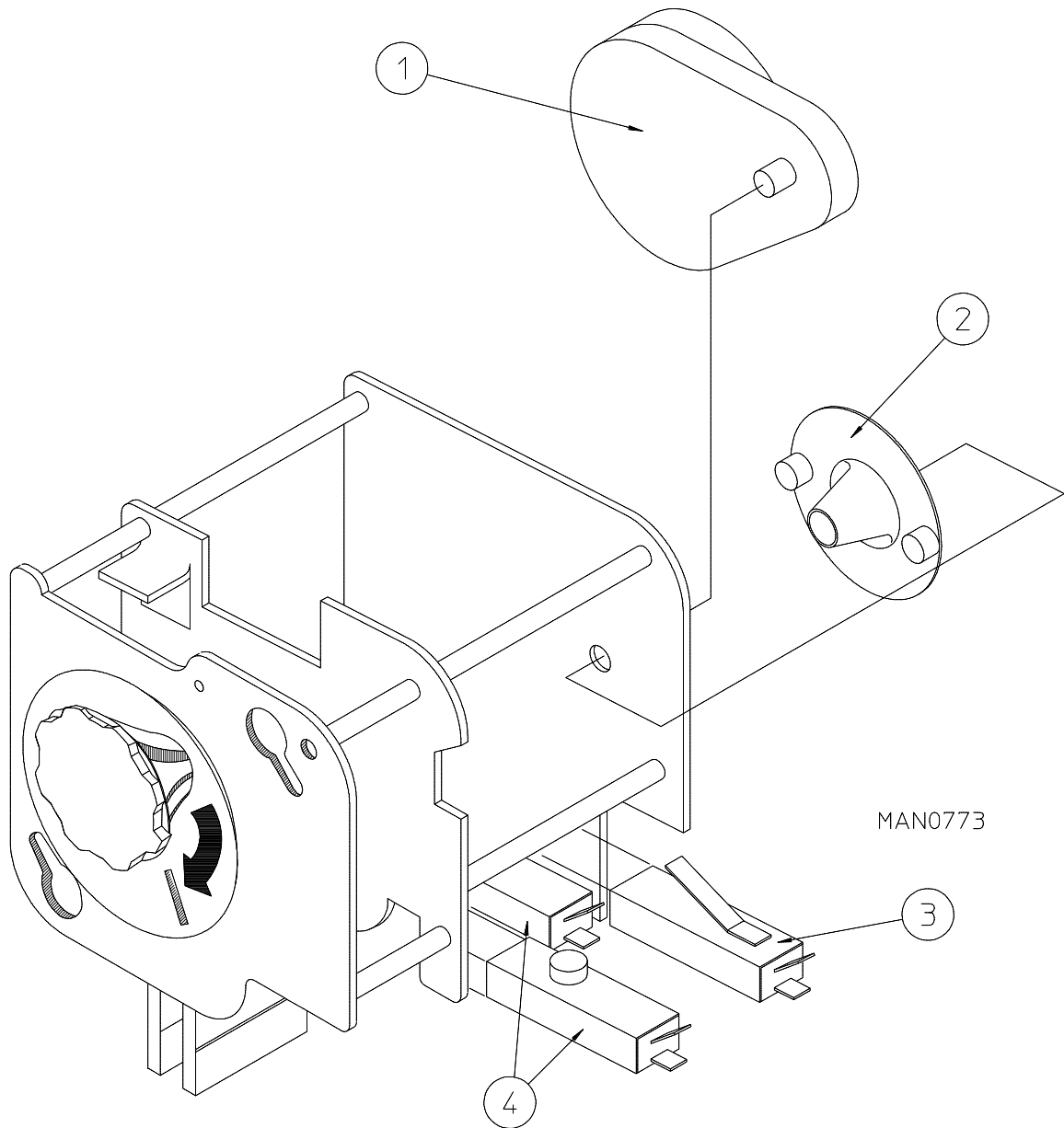

<u>Illus. No.</u>	<u>Part No.</u>	<u>Qty.</u>	<u>Description</u>
1	125541	1	1/60 RPM 24v / 60 Hz Meter Motor
	125540	1	1/30 RPM 24v / 50 Hz Meter Motor
2	125500	1	2-Point Cam
	125501	1	3-Point Cam
	125502	1	4-Point Cam
	125503	1	5-Point Cam
	125504	1	6-Point Cam
	125506	1	8-Point Cam
	125507	1	9-Point Cam
	125508	1	10-Point Cam
	125510	1	12-Point Cam
3	125515	1	Meter Switch "B" with Arm
4	125516	2	Meter Switch "A" or "C"

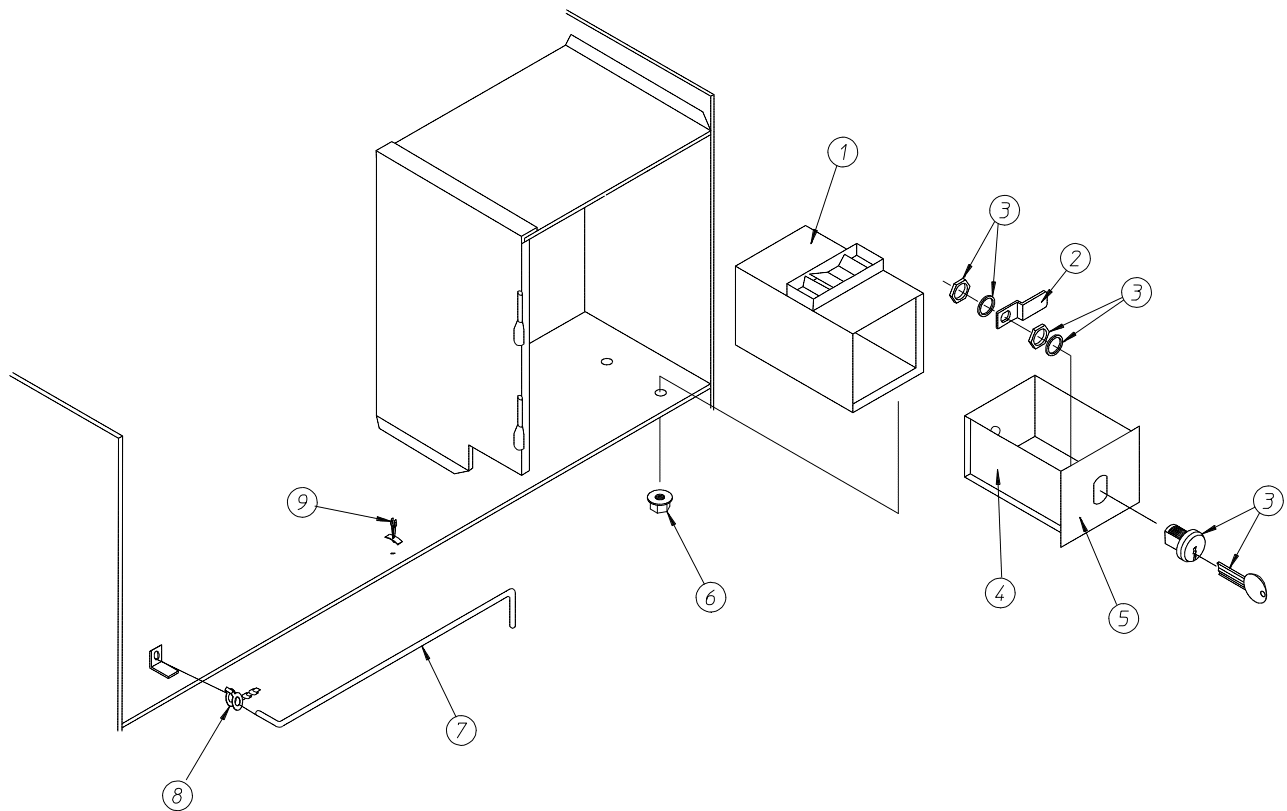

MAN1734

<u>Illus. No.</u>	<u>Part No.</u>	<u>Qty.</u>	<u>Description</u>
1	802112	1	Microprocessor Coin Vault Assembly Complete (includes illus. nos. 1 through 6)
	802117	1	Microprocessor Coin Vault Only
	802110	1	Non-Microprocessor Coin Vault Assembly Complete (includes illus. nos. 1 through 6)
	802115	1	Non-Microprocessor Coin Vault Only
2	160006	1	Cam For 1/4 Turn Lock Only
3	875061	1	1/4 Turn Lock with Key and Cam
	160105*	1	1/4 Turn Mer-Pel Key Only
4	802020	1	1/4 Turn Coin Box Assembly (includes illus. nos. 2 through 5)
	802019	1	1/4 Turn Coin Box Only without Face Plate
	125915	1	High Security (Greenwald) Coin Box Only with Key
5	802018	1	1/4 Turn Coin Box Face Plate Assembly (includes illus. nos. 2 through 5)
6	152014	4	1/4-20 Free Spin Wash Nut
7	102502	1	Control Door Support Rod
8	102601	1	Control Door Rod Retainer Clip
9	102603	1	Control Door Rod Catch

* Specify key number when ordering.

"Plastic" Main Door Assembly

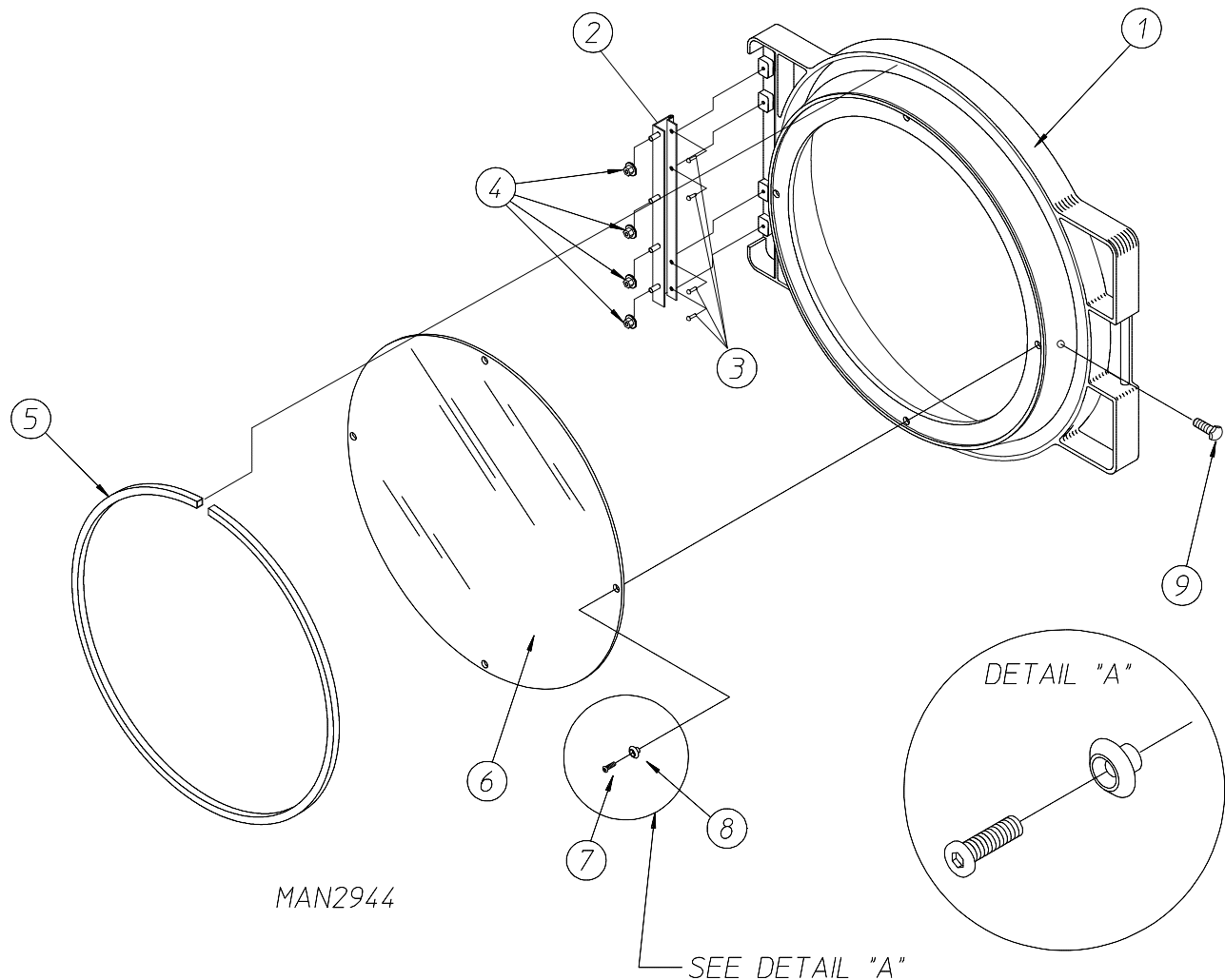

<u>Illus. No.</u>	<u>Part No.</u>	<u>Qty.</u>	<u>Description</u>
1	881421	1	Gray Plastic Main Door Assembly Complete with Mechanical Fasteners (includes illus. nos. 1 and 5 through 9)
2	800448	4	12-1/2" Stainless Steel Main Door Hinge Assembly
3	150410	4	#10-24 x 3/8" Phillips Pan Head Taptite Screw
4	152014	1	1/4-20 Free Spin Wash Nut
5	102349	1	Main Door Gasket
6	102212	1	20-7/16" Door Glass with Four (4) Holes
	170730	1	Main Door Glass Adhesive (10.3 oz. cartridge)
7	150448	4	1/2" Stainless Steel Flat Head Allen Screw
8	170319	4	Door Glass (Nylon) Spacer
9	150431	1	Main Door Latch Screw (#10 x 7/16" dome hex head)

Main Door Switch Assembly For "Plastic" Door

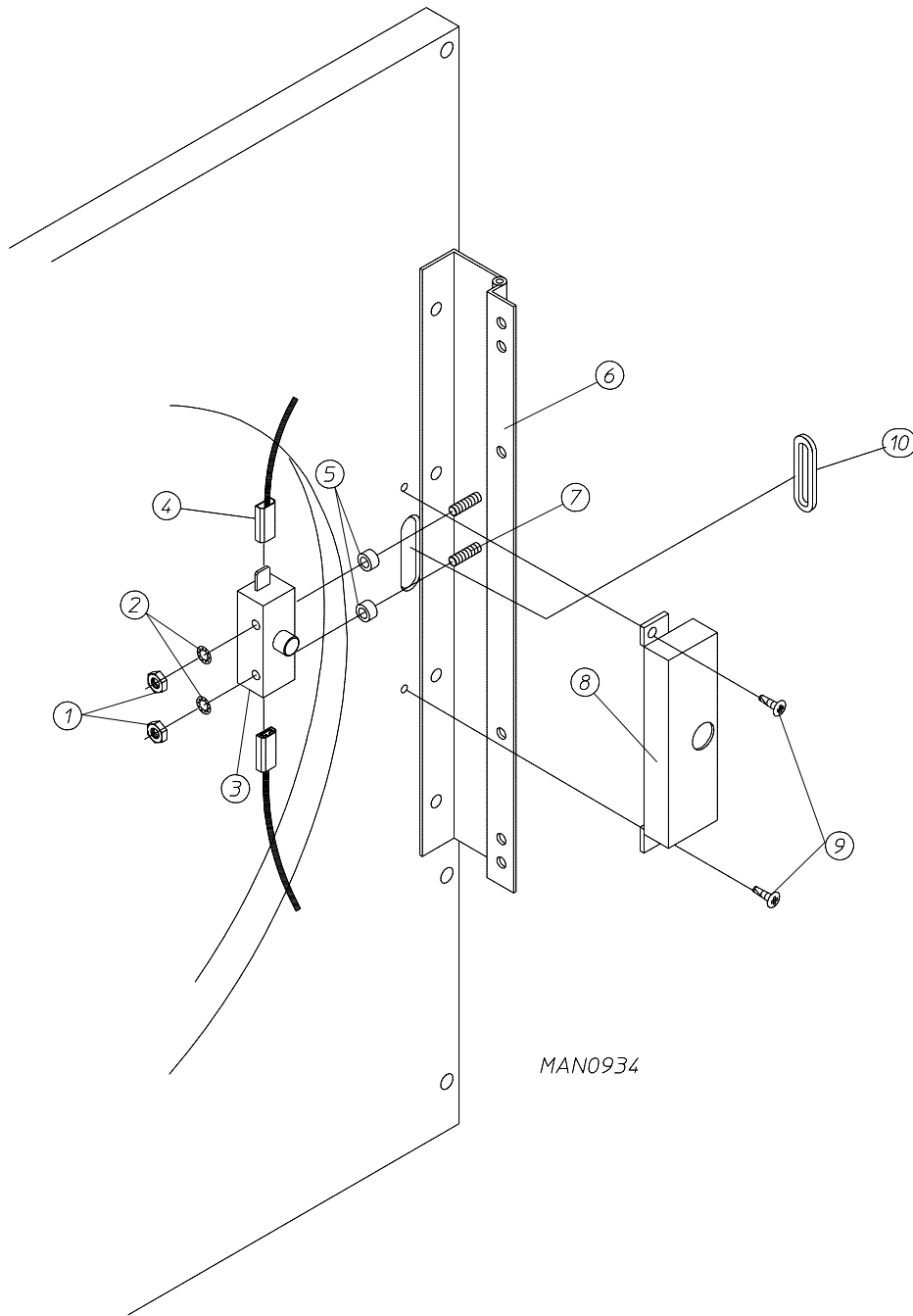

<u>Illus. No.</u>	<u>Part No.</u>	<u>Qty.</u>	<u>Description</u>
1	152013	2	#6-32 Hex Nut
2	153008	2	#6 Lock Washer
3	137005	1	Single-Pole Door Switch
4	121028	2	Insulated Female Terminal
5	154281	2	3/8" Standard Nylon Spacers
6	800448	1	12-1/2" Stainless Steel Main Door Hinge Assembly (includes illus. nos. 6 and 7)
7	153565	2	#6 Stud
8	313218	1	Main Door Switch Housing Only
9	150201	2	#10-32 x 1/4" Phillips Pan Head Screw
10	121405	1	Rubber Grommet

Front Panel Assembly For "Plastic" Door

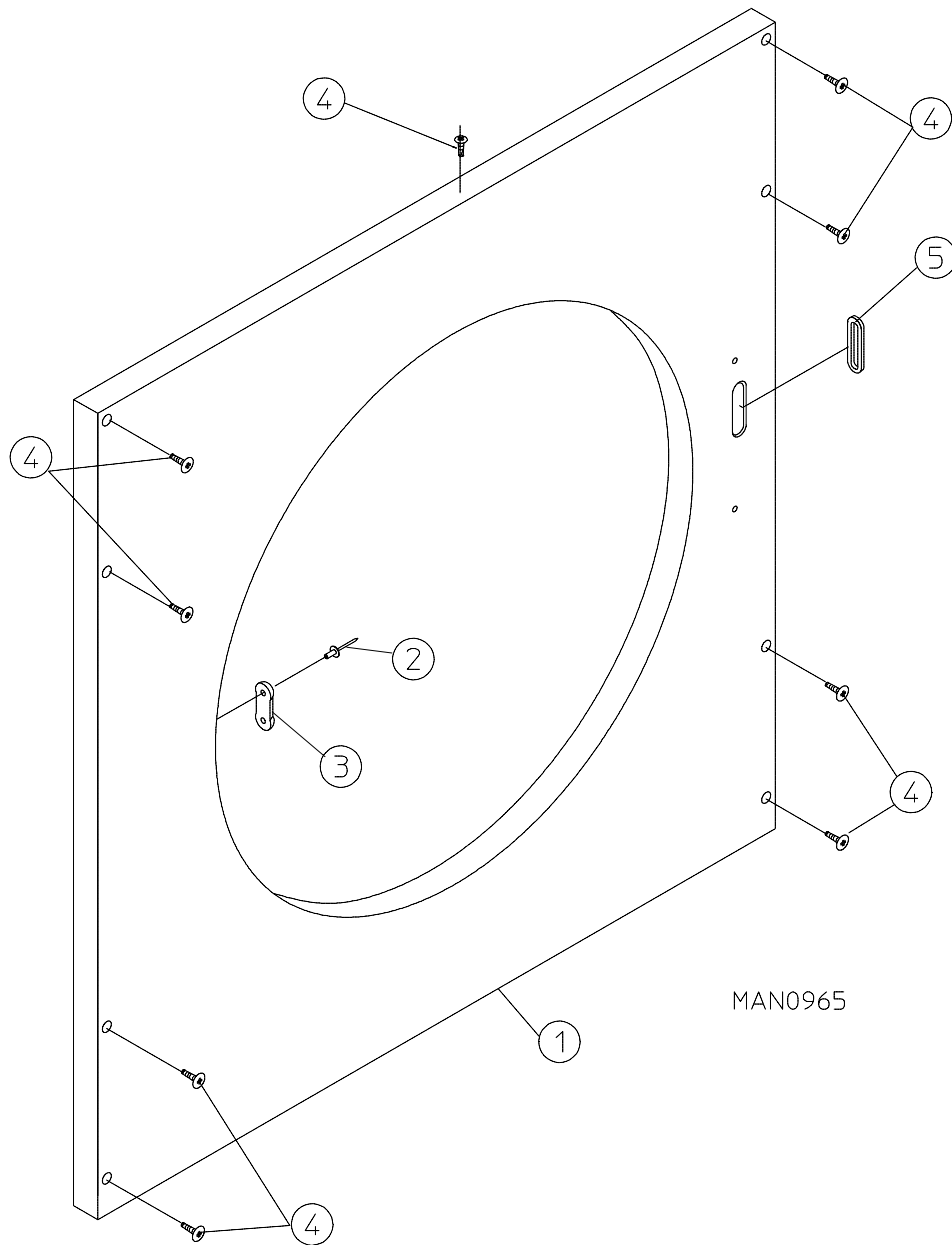

<u>Illus. No.</u>	<u>Part No.</u>	<u>Qty.</u>	<u>Description</u>
1	875301*	1	Insulated Front Panel Assembly Complete – Latch Type (includes illus. nos. 1 through 3 and 5)
	875312	1	Stainless Steel Right-Hand Insulated Front Panel Assembly Complete – Latch Type (includes illus. nos. 1 through 3 and 5)
2	154215	2	1/8" Pop Rivet
3	170330	1	Friction Door Latch
4	150309	9	#10-16 x 1/2" Hex Head TEK Crimptite Screw
	150313	9	#10-16 x 1/2" TORX® Plus Type 1 Screw (for models mfd. as of November 2, 2000)
	150318	-	TORX® Plus Bit
5	121405	1	Rubber Grommet

* Specify color when ordering.

Main Door "Steel" Assembly

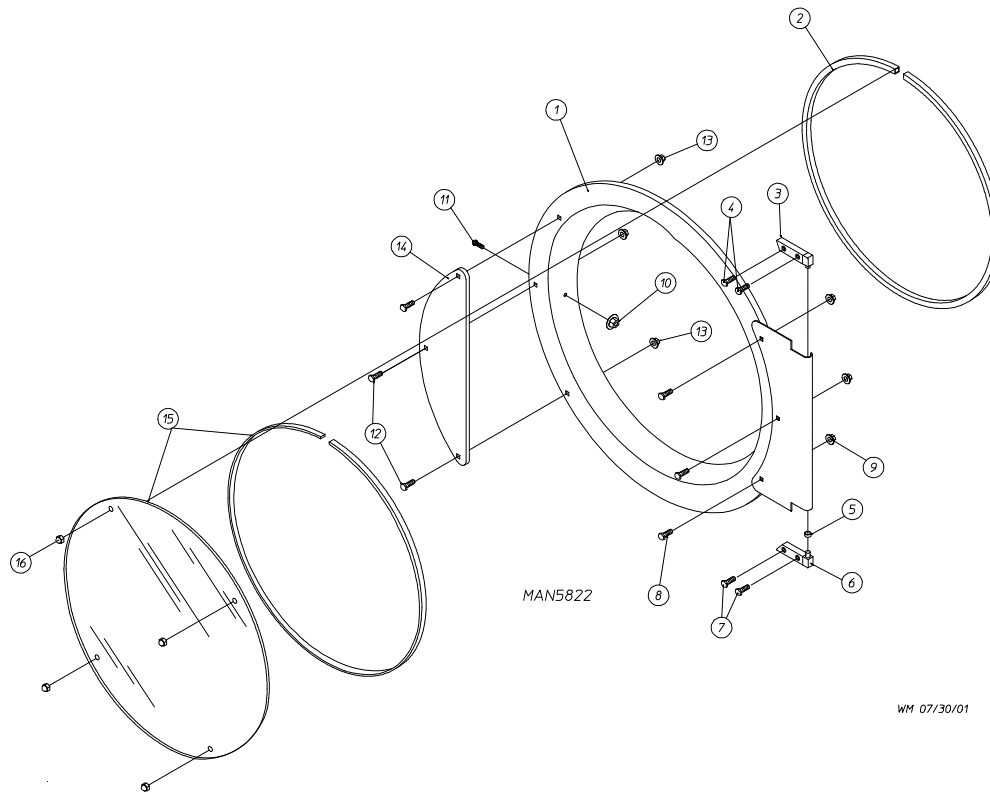

<u>Illus. No.</u>	<u>Part No.</u>	<u>Qty.</u>	<u>Description</u>
1	881150	1	Black Main Door Assembly Complete (includes illus. nos. 1, 2, and 8 through 15)
2	102354	1	Door Gasket
	170730	1	Clear Glass Adhesive (10.3 oz. cartridge)
	170731	1	Black Glass Adhesive (10.3 oz. cartridge)
3	881152	1	Black Top Hinge Block Assembly (includes illus. nos. 3 and 4)
4	150445	2	1/4-20 x 3/4" Black Cap Head Setscrew
5	153031	1	1/4" Nylon Washer
6	881151	1	Black Bottom Hinge Block Assembly (includes illus. nos. 5 through 7)
7	150445	2	1/4-20 x 3/4" Black Cap Head Setscrew
	150443	2	1/4-20 x 3/4" Stainless Steel Cap Head Setscrew
8	150683	3	1/4-20 x 5/8" Black Carriage Bolt
9	152014	3	1/4-20 Free Spin Wash Nut
10	151010	1	#10-32 Black Hex Acorn Nut
11	150120	1	Door Latch Screw
12	150683	3	1/4-20 x 5/8" Black Carriage Bolt
13	152014	3	1/4-20 Free Spin Wash Nut
14	881210	1	Black Main Door Handle Only
15	102218	1	20-7/16" Door Glass
	102360	1	Glass/Door Gasket Tape (for models mfd. as of February 9, 2001)
	170731	1	Black Glass Adhesive (10.3 oz. cartridge) For Models Mfd. prior to February 9, 2001
16	151013	4	#10-32 Black Nylon Acorn Nut

Main Door Switch Assembly Cold Rolled Steel Door

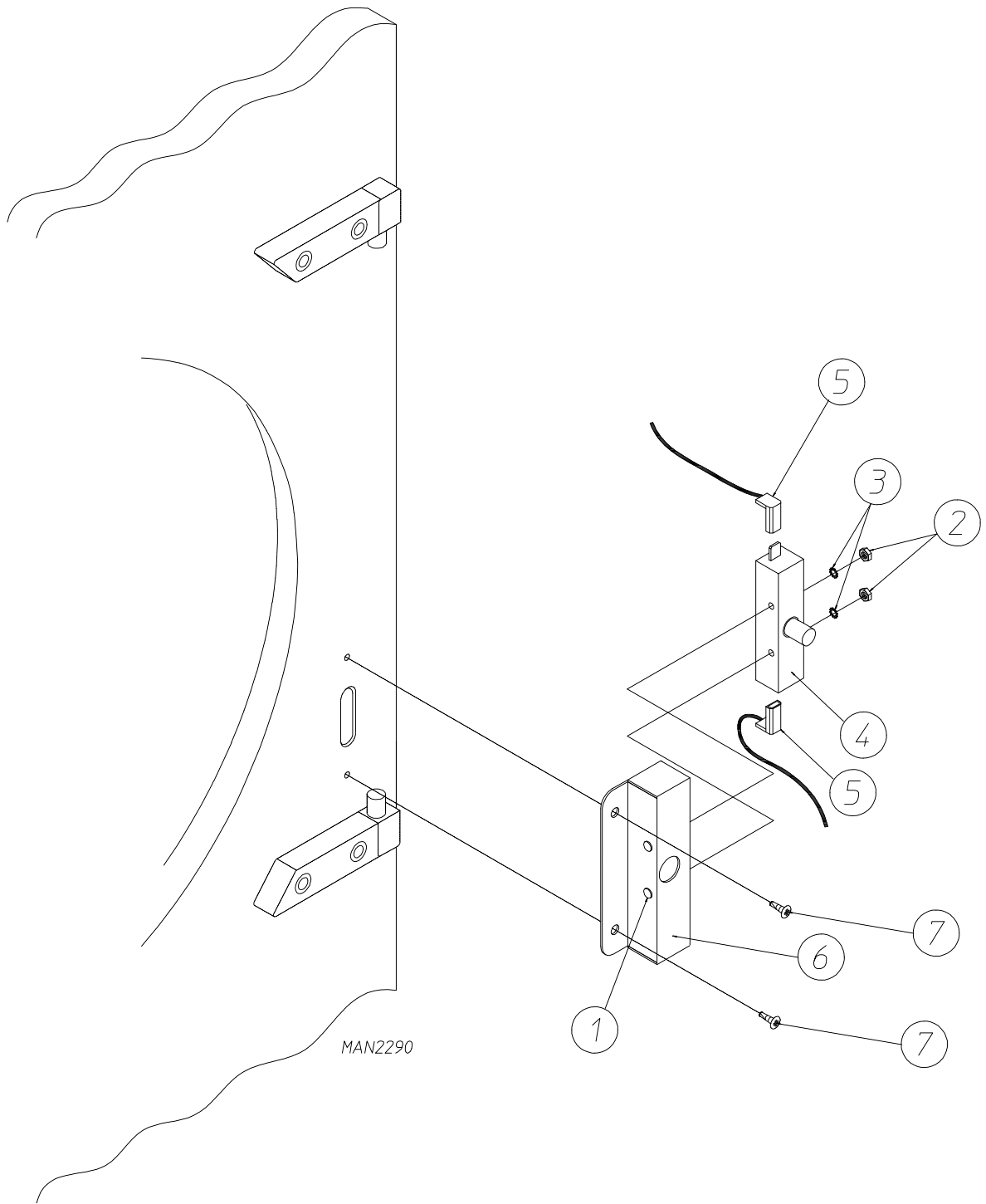

<u>Illus. No.</u>	<u>Part No.</u>	<u>Qty.</u>	<u>Description</u>
1	153566	2	#6-32 x 7/8" Clinch Stud
2	152013	2	#6-32 Hex Nut 1/4" ATF Zinc Plated
3	153010	2	#6 Star Washer
4	137005	1	Single-Pole Door Switch
5	122636	2	Flag Terminal
6	881211	1	Main Door Switch Housing
7	150301	2	#8-18 x 7/16" Phillips Pan Head TEK Screw

Cold Rolled Steel Door Front Panel

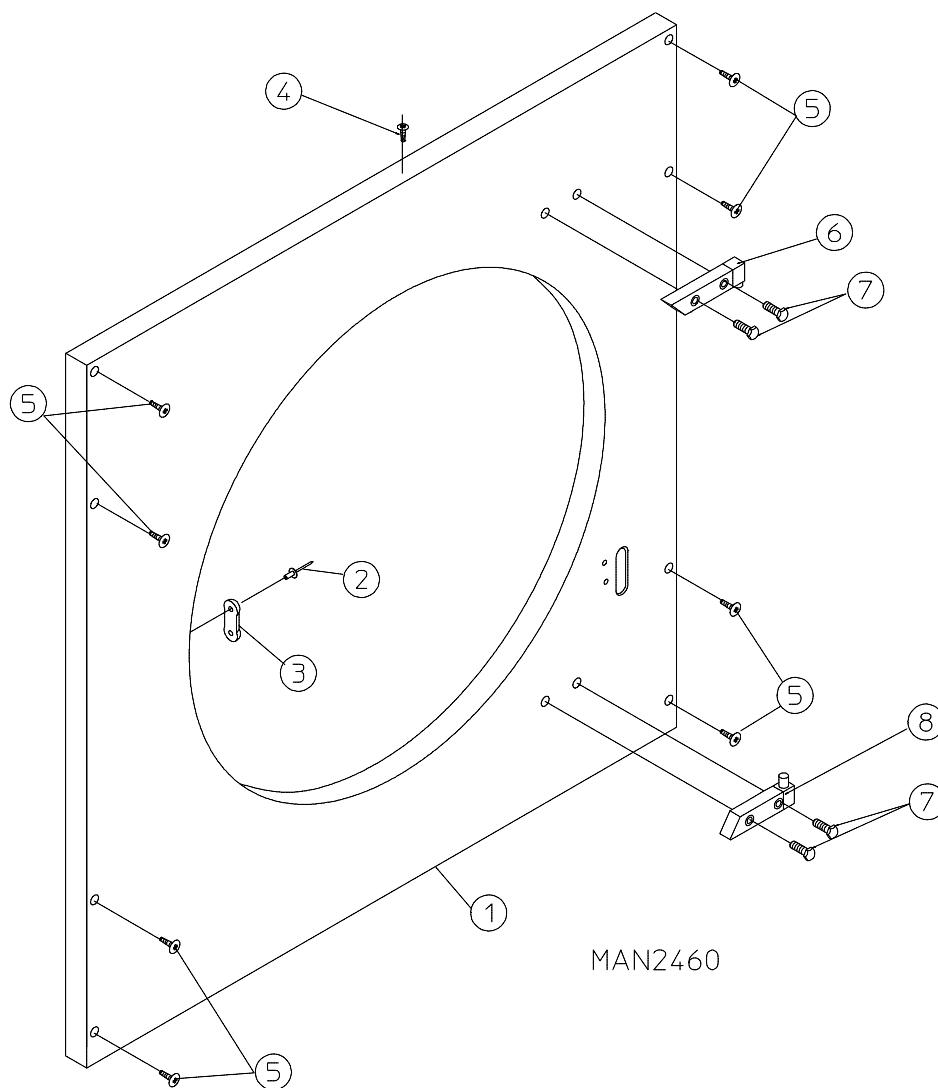

<u>Illus. No.</u>	<u>Part No.</u>	<u>Qty.</u>	<u>Description</u>
1	881270*	1	Right-Hand Front Panel Assembly (cold rolled steel door) (includes illus. nos. 1 through 3)
	881288	1	Stainless Steel Front Panel Assembly (cold rolled steel door) (includes illus. nos. 1 through 3)
	881996*	1	Left-Hand Front Panel Assembly (cold rolled steel door) (includes illus. nos. 1 through 3)
2	154215	2	1/8" Pop Rivet
3	170330	1	Friction Door Latch
4	150300	1	#10-16 x 1/2" Hex Washer TEK Screw
5	150309	8	#10-16 x 1/2" Phillips Hex Head TEK Crimpite Screw
6	881152	1	Black Top Hinge Block Assembly
	881208	1	Stainless Steel Top Hinge Block Assembly
7	150445	4	1/4-20 x 7/8" Black Cap Head Setscrew
	150443	4	1/4-20 x 7/8" Stainless Steel Cap Head Setscrew
8	881151	1	Black Bottom Hinge Block Assembly
	881209	1	Stainless Steel Bottom Hinge Assembly

* Specify color when ordering.

Lint Trap Assembly

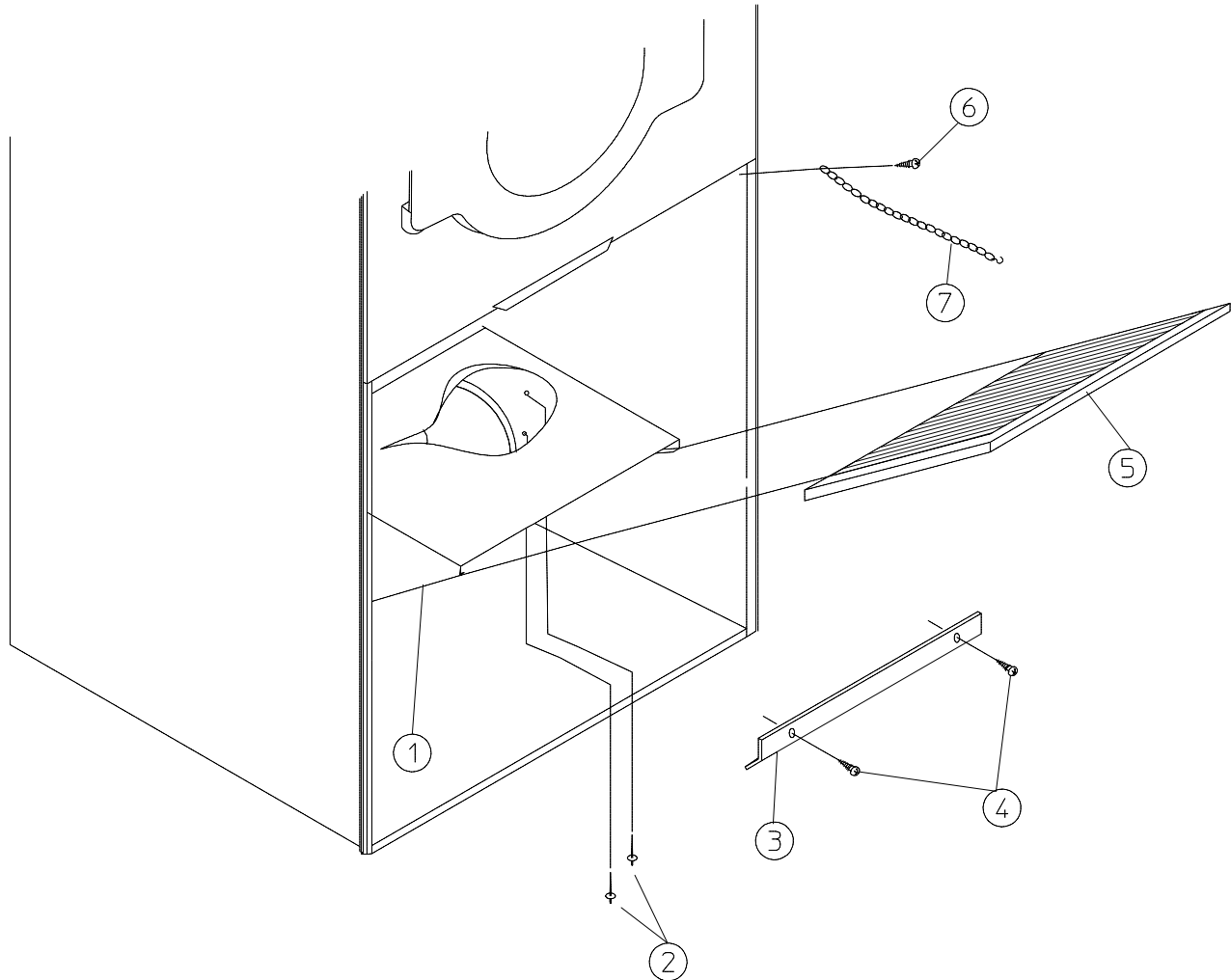

MAN0107

<u>Illus. No.</u>	<u>Part No.</u>	<u>Qty.</u>	<u>Description</u>
1	881064	1	Lint Trap Assembly Complete (includes illus. nos. 1 and 3 through 5)
	881063	1	Lint Trap Only
2	154200	7	5/32" Pop Rivet
3	150300	3	#10 x 1/2" Hex Washer TEK Screw
4	304100	1	Lint Screen Hold Down
5	800506	1	Lint Screen Only
6	150419	2	#6 x 1/2" Tamperproof TEK Screw
7	108120	1	Chain For Drop Lint Door
--	150418	1	Tamperproof Screw Hand Driver

Drop Lint Door Assembly Without Trim

For Non-Coin Models Mfd. as of July 13, 1998

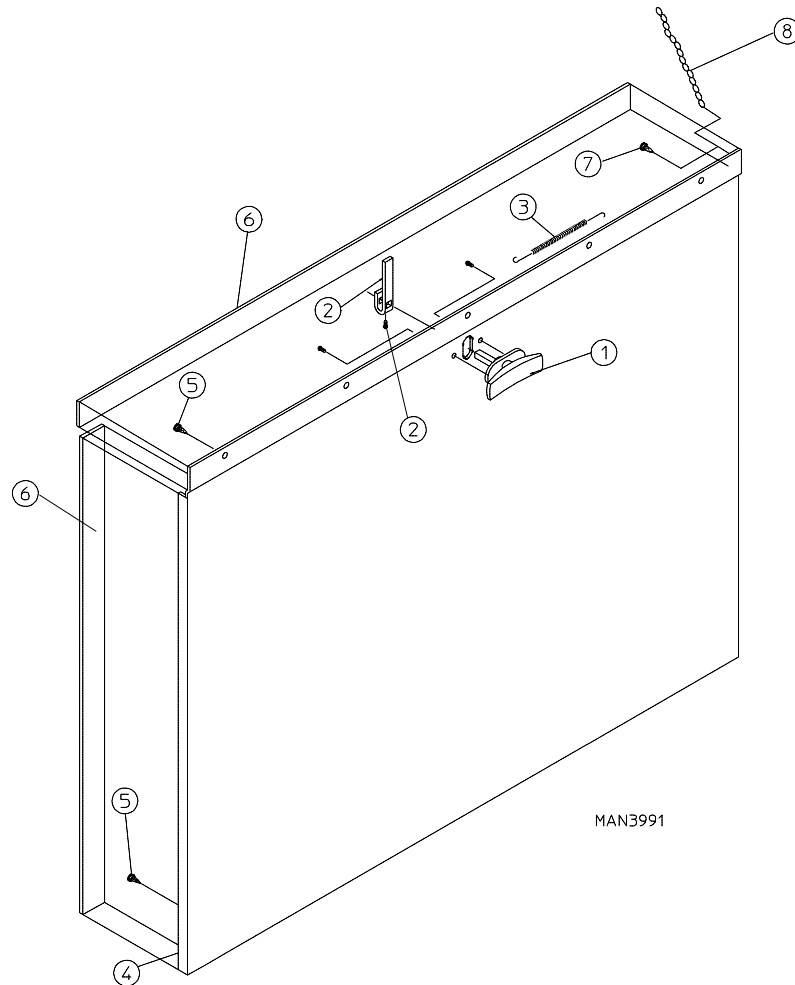

<u>Illus. No.</u>	<u>Part No.</u>	<u>Qty.</u>	<u>Description</u>
1	160001	1	AD-100 Lock Assembly with Key (for coin models Only)
	160103	1	AD-100 Key Only
	800150	1	Knob Latch Kit Assembly (includes illus. nos. 1 and 2)
	160003	1	Dummy Lock Only (for non-coin models)
2	160104	1	MK-100 Key Only (for dummy lock)
	160008	1	Lock Cam For AD-100 and Dummy Lock
	160009	1	Knob Latch Adjustable Cam Only
	150425	1	#12-24 x 3/8" Round Head Machine Screw Only (screw for knob latch adjustable cam)
3	157000	1	Drop Lint Door Spring
4	882264*	1	Insulated Drop Lint Door Assembly (includes illus. nos. 4 through 8)
5	150201	6	#10-32 x 1/4" Phillips Pan Head TEK Screw
6	117604	7	Neoprene Sponge Tape (sold by the foot)
7	150419	2	#6 x 1/2" Tamperproof TEK Screw
8	108120	1	Chain For Drop Lint Door (10-1/2" length)
-	150418	1	Tamperproof Screw Hand Driver

* Specify color when ordering.

Drop Lint Door Assembly With Trim

For ALL Coin Models and Non-Coin Models Mfd. prior to July 13, 1998

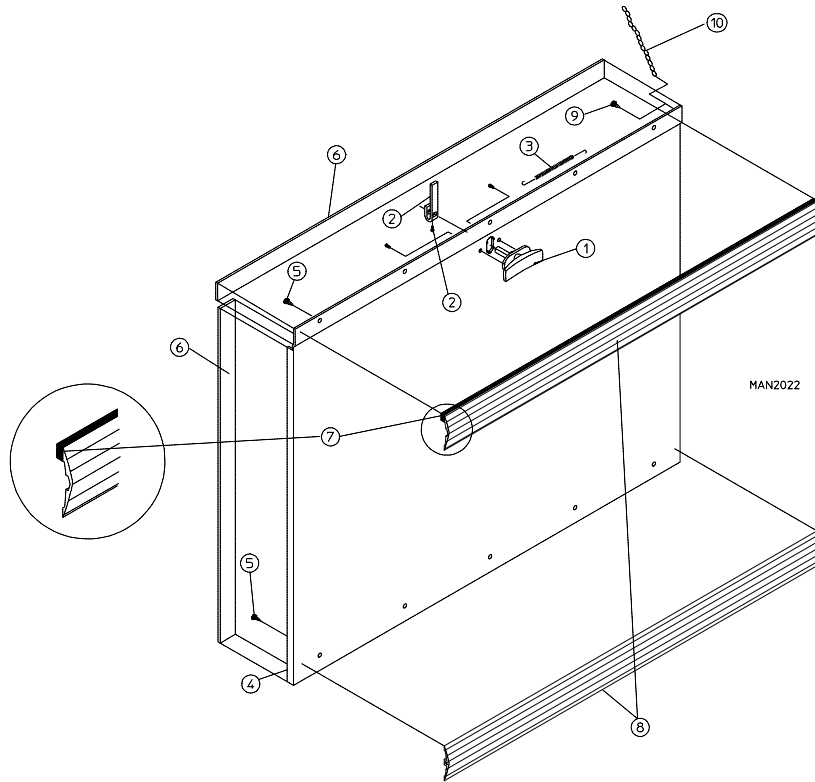

<u>Illus. No.</u>	<u>Part No.</u>	<u>Qty.</u>	<u>Description</u>
1	160001	1	AD-100 Lock Assembly with Key
	160103	1	AD-100 Key Only
	800150	1	Knob Latch Kit Assembly (for non-coin models) (includes illus. nos. 1 and 2)
	160200	1	Knob Latch Kit with Two (2) Screws (for non-coin models)
	160003	1	Dummy Lock Only (for non-coin models)
2	160104	1	MK-100 Key Only
	160008	1	Lock Cam For AD-100 Lock
	160009	1	Knob Latch Adjustable Cam (for non-coin models)
3	150425	1	#12-24 x 3/8" Round Head Machine Screw (for knob latch adjustable cam)
	157000	1	Drop Lint Door Spring
	4	800219*	1
800232*		1	Insulated Drop Lint Door Assembly (includes illus. nos. 4 through 8)
800243		1	Stainless Steel Drop Lint Door Assembly
5	150201	10	#10-32 x 1/4" Phillips Pan Head Machine Screw
6	117600	7	Noise Suppressor Tape (sold by the foot)
7	117603	3	Suppressor Tape / Gasket (sold by the foot)
8	180211	2	Trim / Kick Plate (31-1/8" length)
	150419	2	#6 x 1/2" Tamperproof Screw
9	150418	1	Tamperproof Screw Hand Driver
	108120	1	Chain For Drop Lint Door

* Specify color when ordering.

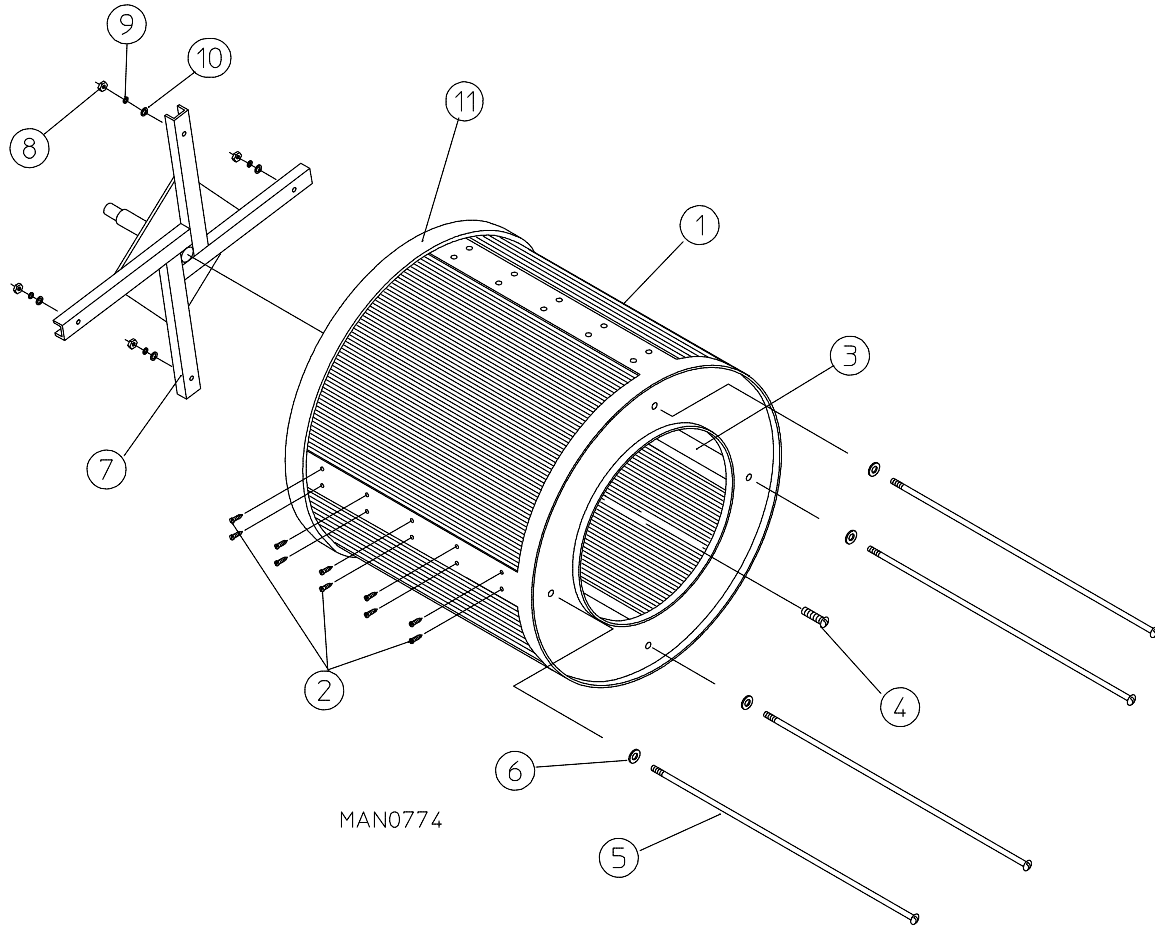

MAN0774

<u>Illus. No.</u>	<u>Part No.</u>	<u>Qty.</u>	<u>Description</u>
1*	800838	1	Tumbler Only with Tapered Rib (without felt collar)
	800837**	1	Non-Reversing Tumbler and Support Assembly with Tapered Rib (includes illus. nos. 1 through 10)
	800839**	1	Reversing Tumbler and Support Assembly with Tapered Rib (includes illus. nos. 1 through 10)
2	150309	40	#10-16 x 1/2" Hex Head TEK Crimptite Screw
3	301302	2	Tumbler Rib Only (low rib)
	301311	2	Tapered Tumbler Baffle Rib Only (high rib)
4	150500	1	5/16-18 x 3/8" Socket Button Head Screw
5	100903	4	5/16-18 x 38-1/2" Tie Rod
6	153004	4	3/8" Flat Washer
7	800616	1	Non-Reversing Tumbler Support Only
	800614	1	Reversing Tumbler Support Only
8	152005	4	3/8-16 Hex Nut
9	153005	4	3/8" Lock Washer
10	153004	4	3/8" Flat Washer
11	116001	1	Felt Collar Only
---	401010	1	#847 Adhesive For Felt Collar (5.0 oz. tube)

* For stainless steel tumbler, contact the factory.

** Felt collar *is not included* and **must be** ordered separately.

Idler Bearing Assembly

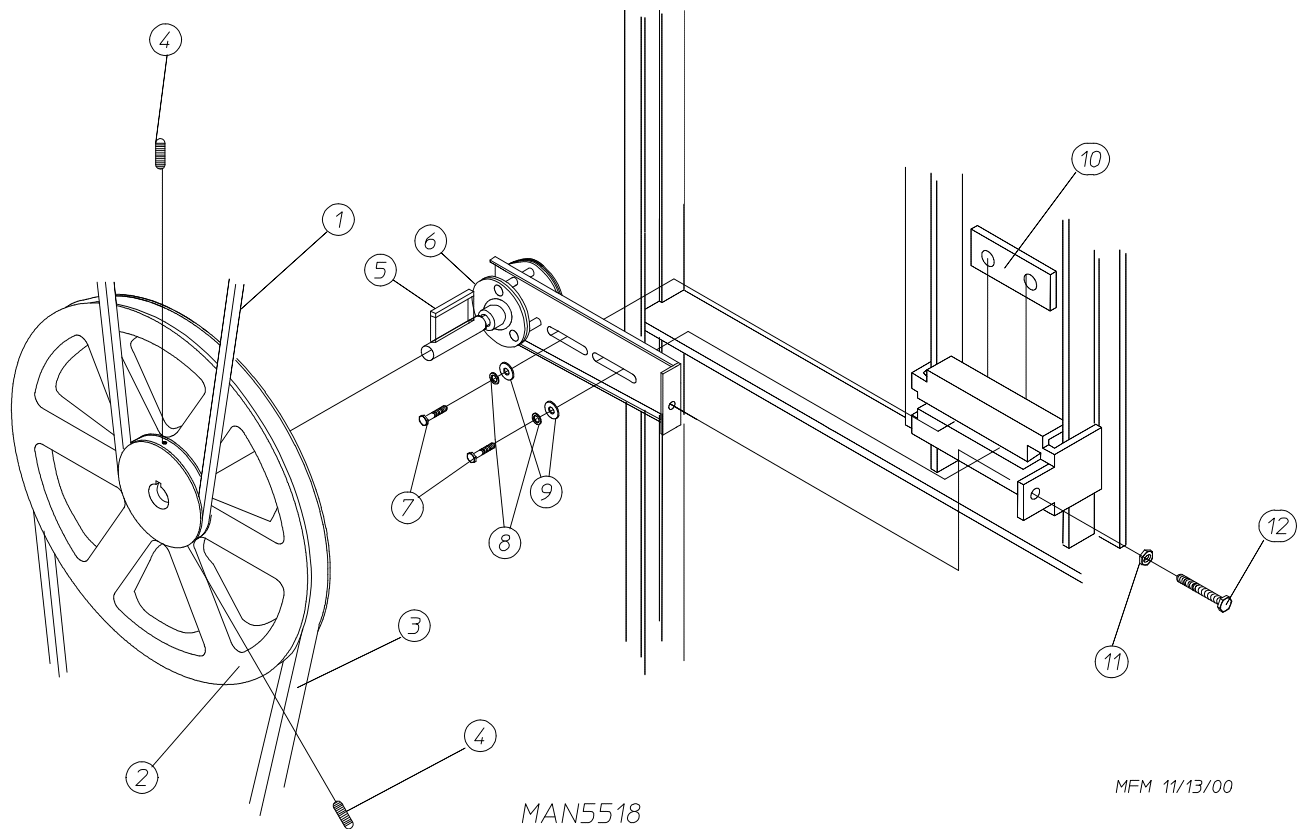

<u>Illus. No.</u>	<u>Part No.</u>	<u>Qty.</u>	<u>Description</u>
1	100165	1	5L-610 V-Belt (idler to tumbler) For Non-Reversing Models Only
	100106	1	5L-690 V-Belt (idler to tumbler) For Reversing Models Only
2	101140	1	14" x 3" Compound Pulley
3	100166	1	4L-790 V-Belt (idler to motor) 60 Hz (for non-reversing models Only)
	100167	1	4L-800 V-Belt (idler to motor) 50 Hz (for non-reversing models Only)
	100109	1	4L-650 V-Belt (idler to motor) 50/60 Hz (for reversing models Only)
4	154301	2	5/16-18 x 1" Allen Setscrew
5	100705	1	3/16" x 3/16" x 1-3/8" Key
6	882576	1	Idler Bearing Assembly Complete (includes illus. nos. 5 through 12)
7	150617	2	3/8-16 x 1" Hex Head Machine Bolt
8	153005	2	3/8" Lock Washer
9	153004	2	3/8" Flat Washer
10	801009	1	Idler Square Washer
11	152004	1	5/16-18 Hex Nut
12	150509	1	5/16-18 x 3" Hex Head Machine Bolt

Tumbler Bearing Assembly

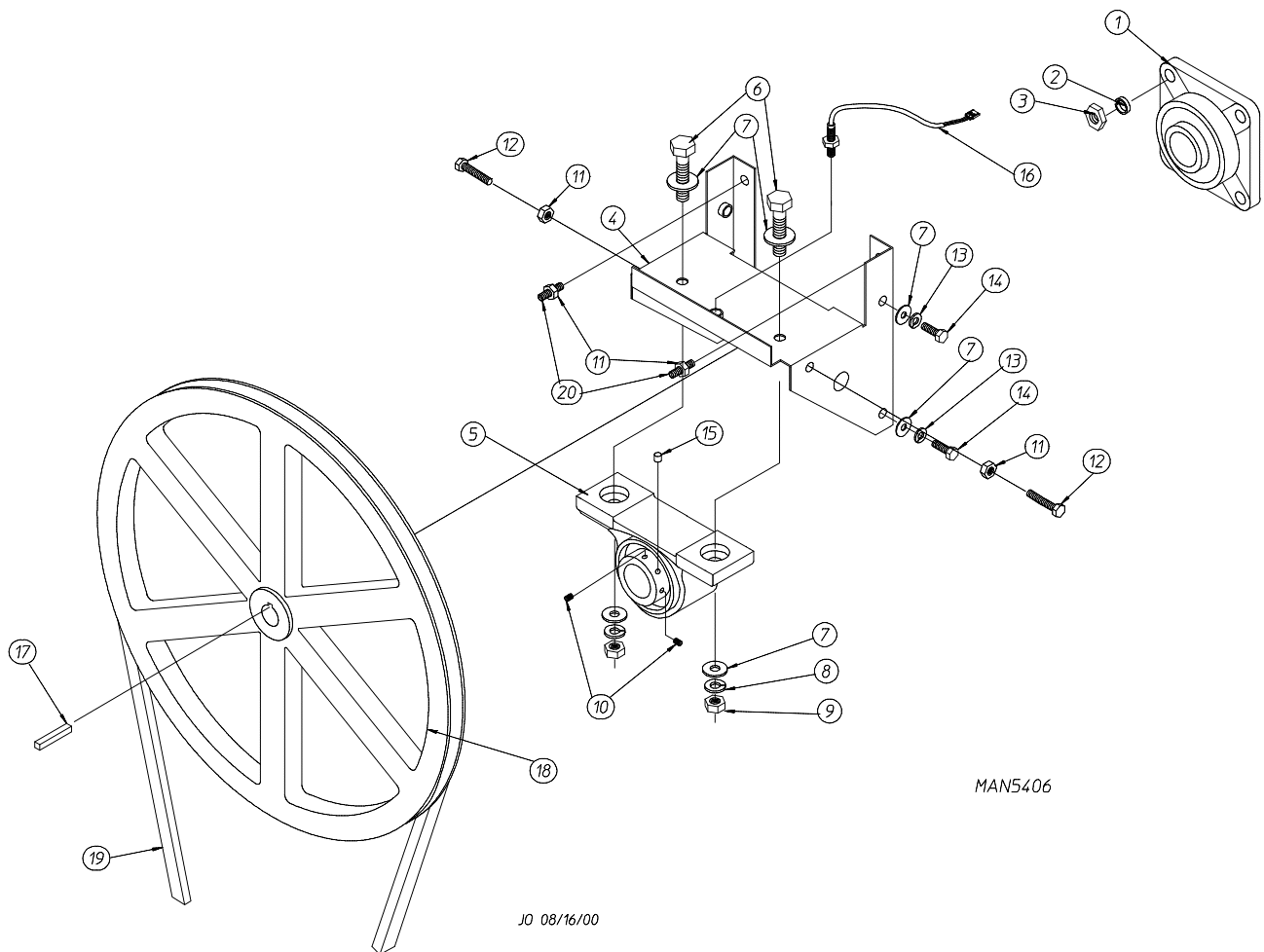

MAN5406

JO 08/16/00

Tumbler Bearing Assembly

<u>Illus. No.</u>	<u>Part No.</u>	<u>Qty.</u>	<u>Description</u>
1	880220	1	1-3/8" Flange Bearing Only
2	153005	4	3/8" Lock Washer
3	152005	4	3/8-16 Hex Nut
4	882544	1	Pillow Block Bearing Assembly Complete (includes illus. nos. 4 through 14 and 20)
	882545	1	Bearing Assembly Complete with Rotational Sensor (includes illus. nos. 4 through 16 and 20)
	882542	1	Bearing Support Only
	882543	1	Bearing Support Only (with rotational sensor)
5	880202	1	1-3/8" Pillow Block Bearing Only
	880779	1	1-3/8" Pillow Block Bearing Assembly (with rotational sensor)
6	150601	2	3/8-16 x 2" Hex Bolt
7	153004	8	3/8" Flat Washer
8	153005	2	3/8" Lock Washer
9	152005	2	3/8-16 Hex Nut
10	154326	2	5/16-24 x 3/8" Setscrew (black)
11	152004	4	5/16-18 Hex Nut
12	150621	2	5/16-18 x 1-1/2" Tap Bolt
13	153002	4	5/16" Lock Washer
14	150501	4	5/16-18 x 3/4" Tap Bolt
15	102120	1	Sintered 8 Magnet
	401010	1	#847 Construction Mastic
16	824807	1	Rotational Sensor Assembly
17	100713	1	1/4" x 1/4" x 7/8" Key
18	101100	1	18" Pulley
19	100106	1	5L-690 V-Belt
20	150610	2	5/16-18 x 1-1/2" Allen Setscrew

Non-Reversing Totally Enclosed, Fan-Cooled Motor Mount Assembly

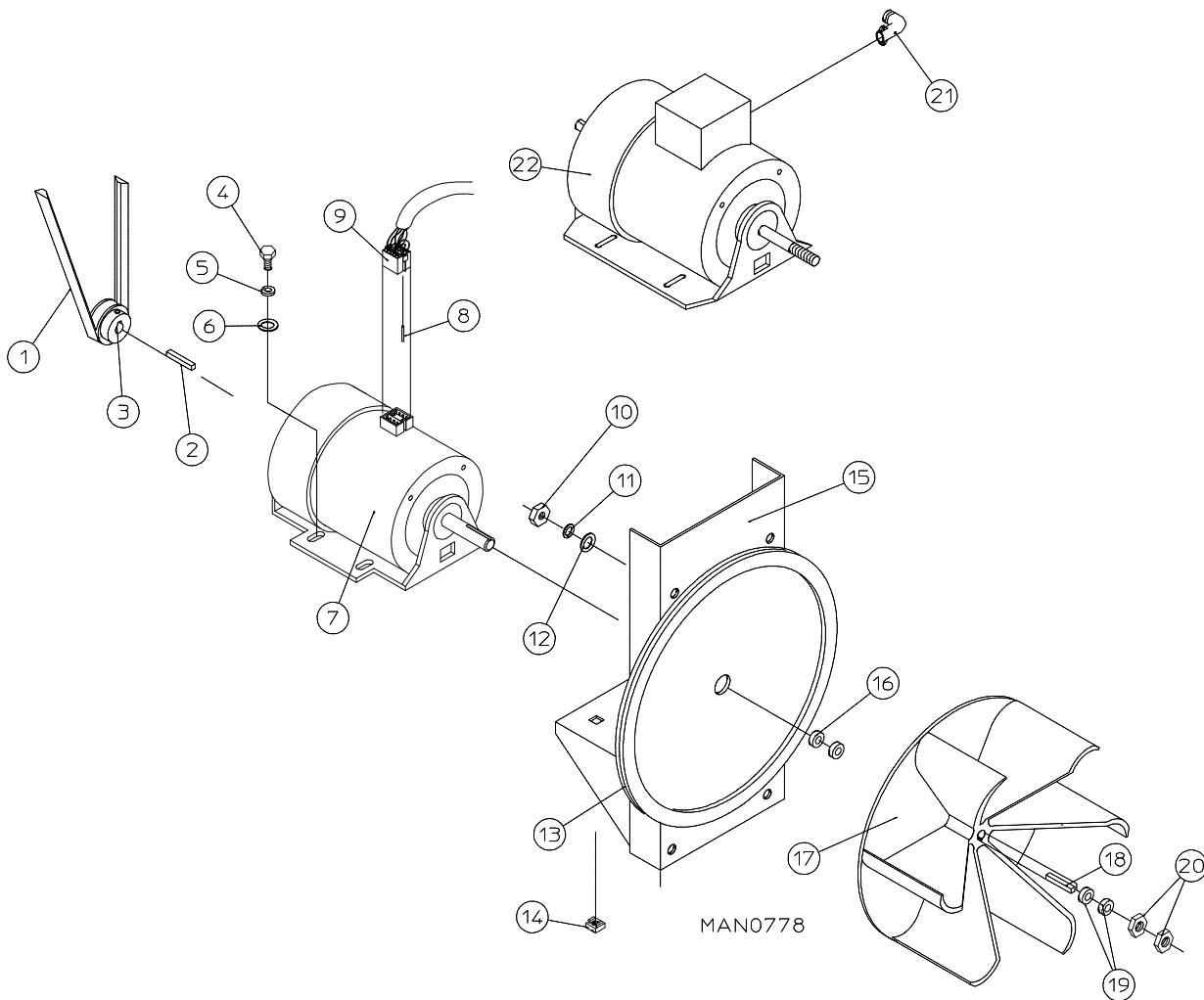

<u>Illus. No.</u>	<u>Part No.</u>	<u>Qty.</u>	<u>Description</u>
1	100166	1	4L-790 V-Belt (to idler assembly) 50/60 Hz Only
2	100701	1	3/16" x 3/16" x 1" Key
3	101130	1	5/8" x 2-1/2" Motor Pulley (60 Hz motors Only)
	101139	1	5/8" x 2-3/4" Motor Pulley (50 Hz motors Only)
4	150501	4	5/16-18 x 3/4" Hex Head Machine Bolt
5	153002	4	5/16" Lock Washer
6	153001	4	5/16" Flat Washer
7	100073	1	1 hp 115-230v 1ø 60 Hz Non-Reversing Totally Enclosed, Fan-Cooled Motor (plug type)
	181016	1	3/4 hp 240v 1ø 50 Hz Non-Reversing Totally Enclosed, Fan-Cooled Motor (plug type)
8	122701	8	Socket Terminal Only
	122801	1	Pin / Socket Extraction Tool
9	137030	1	8-Pin Housing Connector
10	152004	4	5/16-18 Hex Nut

Non-Reversing Totally Enclosed, Fan-Cooled Motor Mount Assembly

<u>Illus. No.</u>	<u>Part No.</u>	<u>Qty.</u>	<u>Description</u>
11	153002	4	5/16" Lock Washer
12	153001	4	5/16" Flat Washer
13	117600	4	Noise Suppressor Tape (sold by the foot)
14	154000	4	5/16-18 Tinnerman Nut
15	800919	1	1 hp Motor Mount Only (56Z frame) (includes illus. no. 13)
	803903	1	1 hp 115-230v 1ø 60 Hz Totally Enclosed, Fan-Cooled Motor Mount Assembly Complete with Plug Motor (includes illus. nos. 2 through 7 and 13 through 20)
	881080	1	3/4 hp 240v 1ø 60 Hz Totally Enclosed, Fan-Cooled Motor Mount Assembly Complete (includes illus. nos. 2 through 7 and 13 through 20) For Models Mfd. as of February 21, 1995
	803904	1	3/4 hp 240v 1ø 50 Hz Totally Enclosed, Fan-Cooled Motor Mount Assembly Complete (includes illus. nos. 2 through 6 and 13 through 22) For Models Mfd. prior to February 21, 1995
	803905*	1	1 hp 208/230/380/460v 3ø 50 Hz Totally Enclosed, Fan-Cooled Motor Mount Assembly Complete (includes illus. nos. 2 through 6 and 13 through 22)
	881065*	1	1 hp 208/230/380/460v 3ø 50 Hz Totally Enclosed, Fan-Cooled Motor Mount Assembly Complete (includes illus. nos. 2 through 6 and 13 through 22)
16	153050	2	1/2" S.A.E. Flat Washer
17	100603	1	16" Impellor with 3/4" Bore
18	100702	1	1/8" x 1/8" x 1-1/2" Key
19	153050	2	1/2" S.A.E. Flat Washer
20	152006	2	1/2-20 Left-Hand Jam Nut
21	120200	1	3/8 x 90° Connector
22	100075	1	1 hp 208/230/380 460v 3ø 50/60 Hz Totally Enclosed, Fan-Cooled Motor (56Z frame)
	100076	1	3/4 hp 240v 1ø 50 Hz Totally Enclosed, Fan-Cooled Motor (56Z frame) For Models Mfd. prior to February 21, 1995

* Specify voltage when ordering.

Reversing Totally Enclosed, Fan-Cooled Motor Mount Assembly

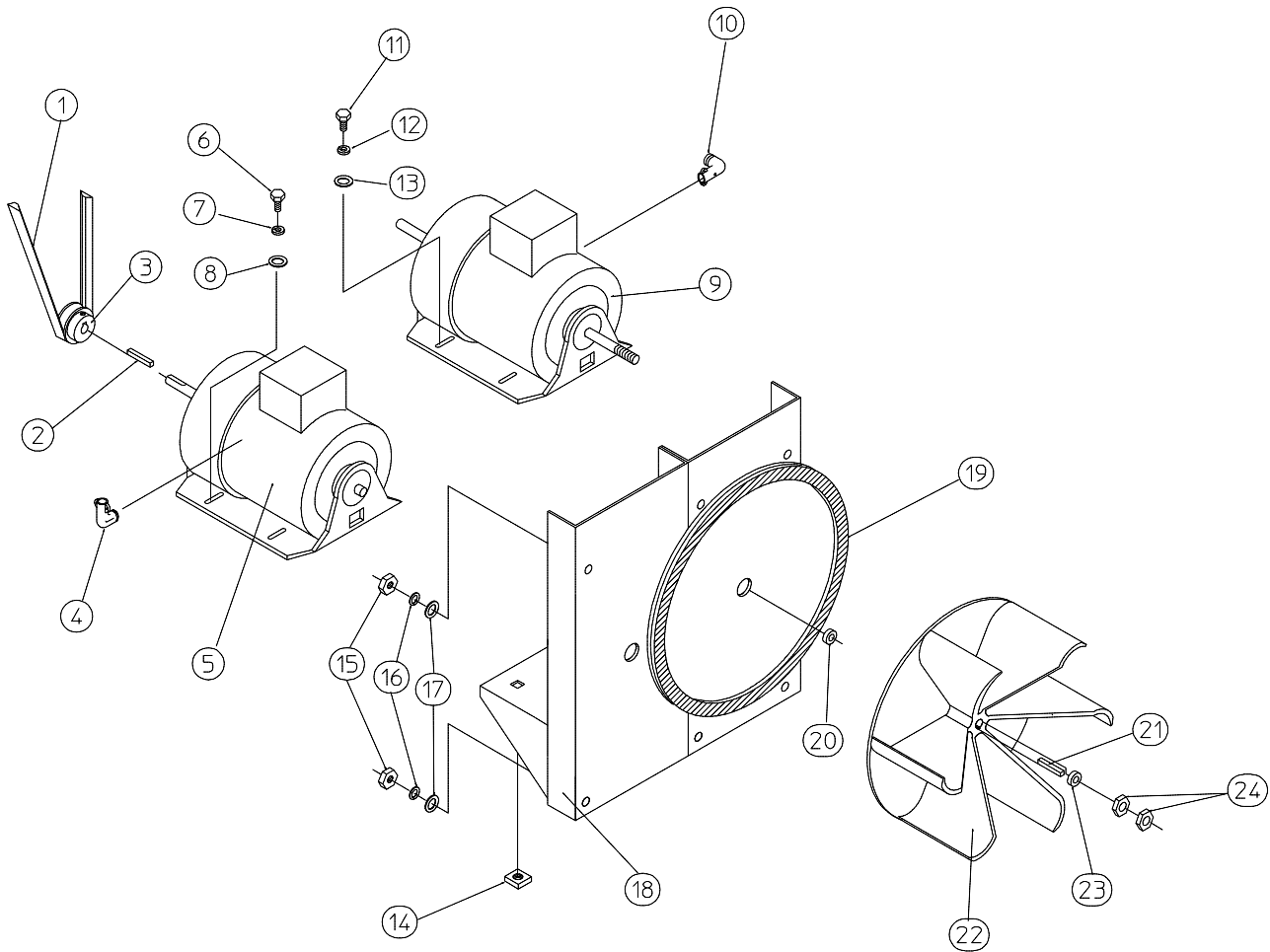

MAN0250

Reversing Totally Enclosed, Fan-Cooled Motor Mount Assembly

<u>Illus. No.</u>	<u>Part No.</u>	<u>Qty.</u>	<u>Description</u>
1	100109	1	4L-650 V-Belt (to idler assembly)
2	100701	1	3/16" x 3/16" x 1" Key
3	101130	1	5/8" x 2-1/2" Motor Pulley (60 Hz)
	101139	1	5/8" x 2-3/4" Motor Pulley (50 Hz)
4	120200	1	3/8" x 90° Connector
5	181003	1	1/2 hp 208/230/380/460v 3ø 50/60 Hz Totally Enclosed, Fan-Cooled Motor (56Z frame)
6	150501	4	5/16-18 x 3/4" Hex Head Machine Bolt
7	153002	4	5/16" Lock Washer
8	153001	4	5/16" Flat Washer
9	100075	1	1 hp 208/230/380/460v 3ø 50/60 Hz Totally Enclosed, Fan-Cooled Motor (56Z frame)
10	120200	1	3/8" x 90° Connector
11	150501	4	5/16-18 x 3/4" Hex Head Machine Bolt
12	153002	4	5/16" Lock Washer
13	153001	4	5/16" Flat Washer
14	154000	8	5/16" Tinnerman
15	152004	4	5/16-18 Hex Nut
16	153002	4	5/16" Lock Washer
17	153001	4	5/16" Flat Washer
18	800920	1	Reversing Motor Mount Only (56Z frame) (includes illus. no. 19)
	881067*	1	Reversing Totally Enclosed, Fan-Cooled Motor Mount Assembly Complete (includes illus. nos. 2 through 14 and 18 through 24) For 60 Hz Models Only
	881066*	1	Reversing Totally Enclosed, Fan-Cooled Motor Mount Assembly Complete (includes illus. nos. 2 through 14 and 18 through 24) For 50 Hz Models Only
19	117600	5	Noise Suppressor Tape (sold by the foot)
20	153050	2	1/2" S.A.E. Flat Washer
21	100702	1	1/8" x 1/8" x 1-1/2" Key
22	100603	1	16" Impellor with 3/4" Bore
23	153050	2	1/2" S.A.E. Flat Washer
24	152006	2	1/2-20 Left-Hand Jam Nut

* Specify voltage when ordering.

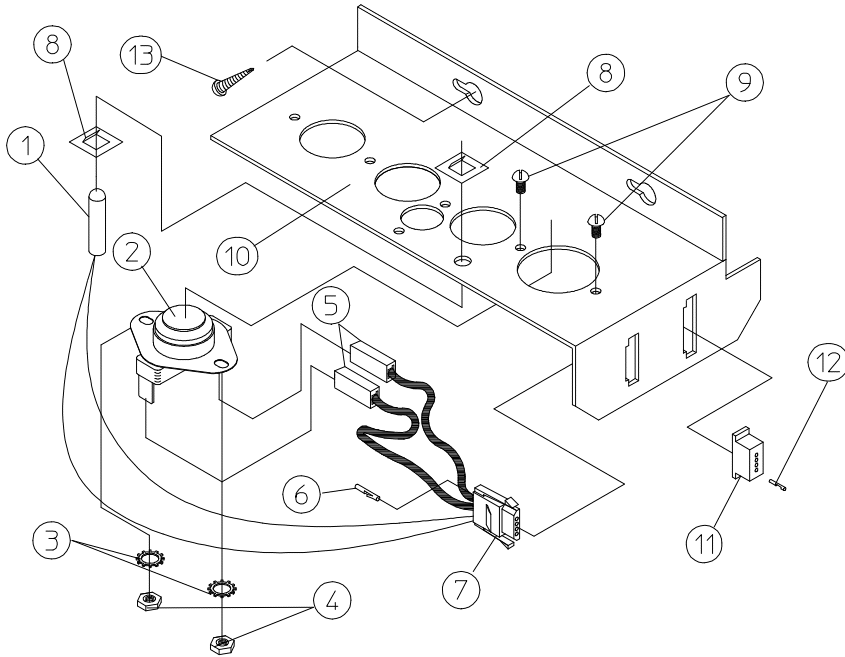

MICROPROCESSOR SENSOR BRACKET ASSEMBLY

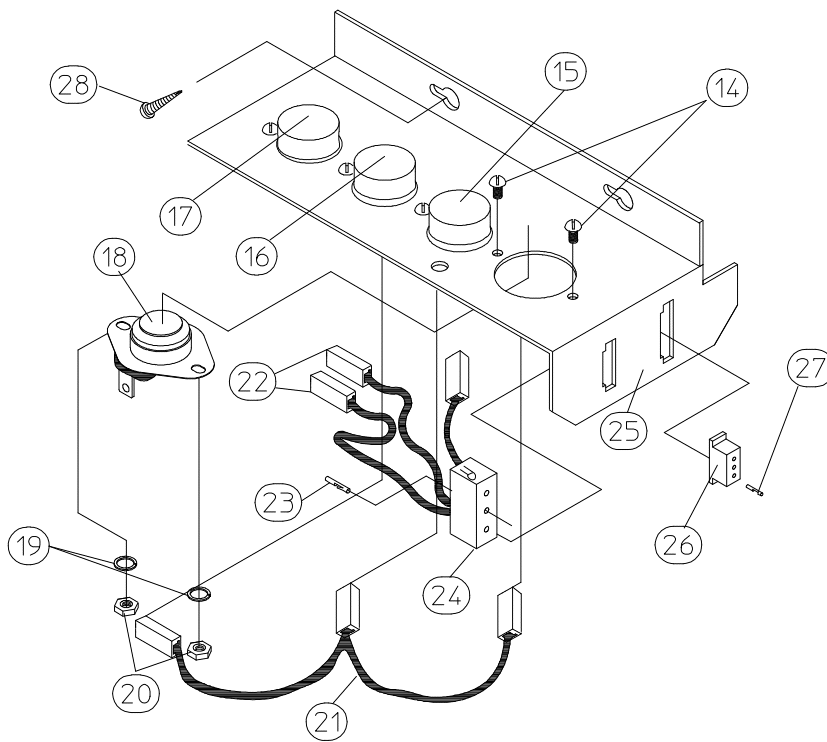

NON-COMPUTER SENSOR BRACKET ASSEMBLY

MAN0238

Sensor Bracket Assemblies

<u>Illus. No.</u>	<u>Part No.</u>	<u>Qty.</u>	<u>Description</u>
1	880251	1	1/4" Temperature Sensor Probe Assembly (includes illus. nos. 1 and 5 through 8)
2	130103	1	225° Large Automatic Thermostat
	130301	1	225° Manual Reset Thermostat
3	153010	2	#6 Star Washer
4	152000	2	#6-32 Hex Nut
5	121028	2	Insulated Terminal Only
6	122701	4	Socket Terminal Only
7	122605	1	4-Pin Socket Connector Only
8	154007	2	1/4" Tinnerman Push On Fastener
9	150005	2	#6-32 x 1/4" Round Head Machine Screw
10	801425	1	Microprocessor Sensor Bracket Assembly Complete (includes illus. nos. 1 through 10)
	305007	1	Universal Sensor Bracket Only
11	122604	1	4-Pin Connector Only
12	122700	4	Pin Terminal Only
13	150301	2	#8-18 x 7/16" Phillips Pan Head TEK Screw
14	150005	5	#6-32 x 1/4" Round Head Machine Screw
15	130111	1	130° Large Thermostat
16	130100	1	150° Large Thermostat
17	130103	1	225° Large Automatic Reset Thermostat
	130301	1	225° Manual Reset Thermostat
18	130101	1	180° Large Thermostat
19	153010	5	#6 Star Washer
20	152000	5	#6-32 Hex Nut
21	840065	1	Sensor Jumper (4)
22	121028	8	Insulated Terminal Only
23	122701	4	Socket Terminal Only
24	122605	1	4-Pin Socket Connector Only
	831702	1	Sensor (4) Bracket Harness Assembly (includes illus. nos. 22 through 24)
25	801418	1	Non-Computer Sensor (4) Bracket Assembly Complete (includes thermostats) (includes illus. nos. 14 through 25)
	305007	1	Universal Sensor Bracket Only
26	122604	1	4-Pin Connector Only
27	122700	4	Pin Terminal Only
	122801	1	Pin / Socket Extraction Tool
28	150301	2	#8-18 x 7/16" Phillips Pan Head TEK Screw

Direct Spark Ignition Burner Assembly

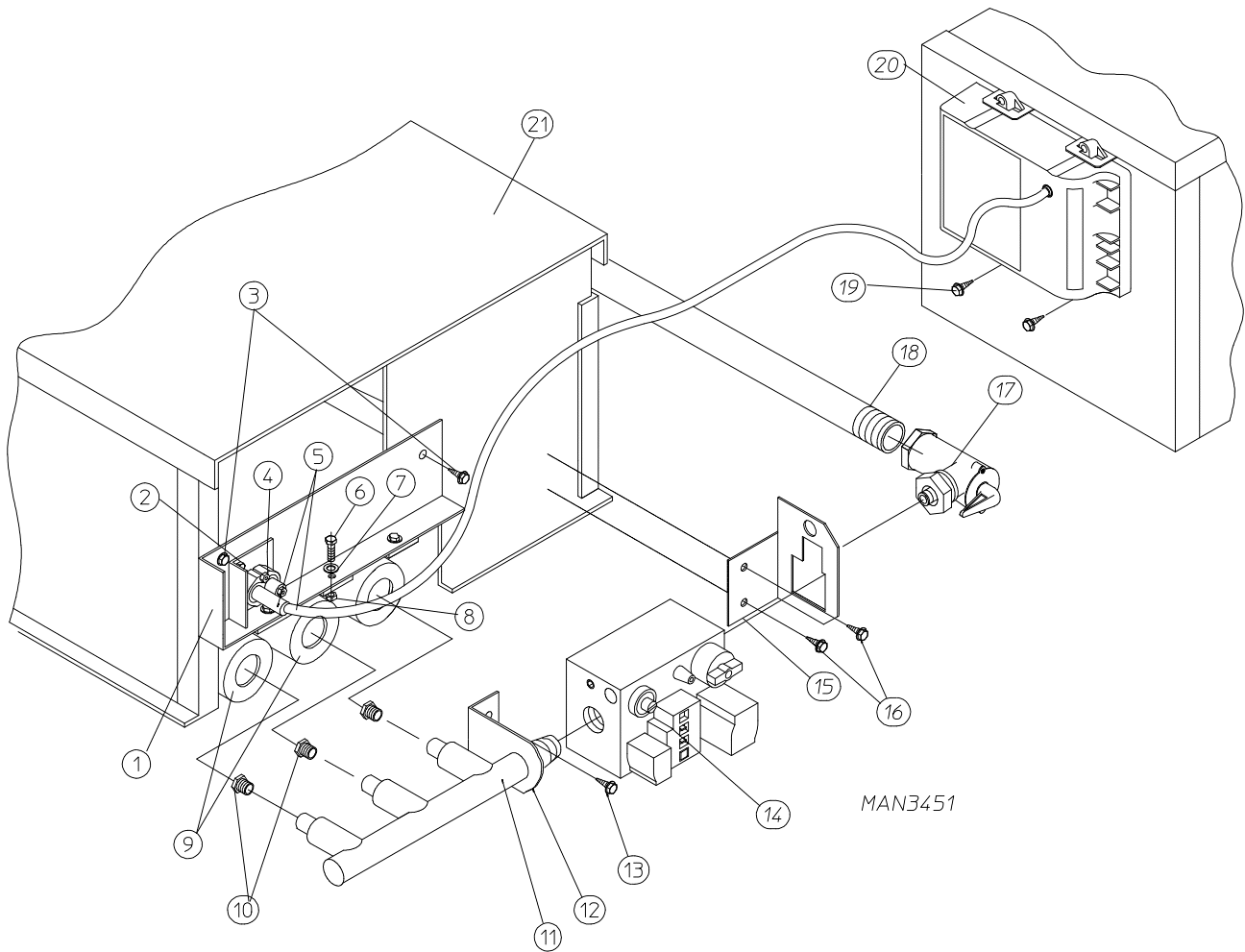

Direct Spark Ignition Burner Assembly

<u>Illus. No.</u>	<u>Part No.</u>	<u>Qty.</u>	<u>Description</u>
1	318030	1	Direct Spark Ignition Burner Shield
2	150300	2	#10 x 1/2" Hex Washer TEK Screw
3	150309	2	#10-16 x 1/2" Hex Head TEK Crimptite Screw
4	128915	1	Direct Spark Ignition Ignitor / Flame Probe Assembly
	880134	1	Ignitor / Flame Probe Kit Assembly (includes illus. nos. 4 and 5)
5	880330	1	High Voltage Wire and Connector Assembly
6	150103	3	#8-32 x 1/2" Pan Head Machine Screw
7	153000	3	#8 Steel Burr
8	151001	3	#8-32 Pal Nut
9	141105	3	Large Tube Burner
10*	140856	3	#23 Natural Gas Burner Orifice (60 Hz Only)
	140810	3	#42 Liquid Propane Gas Burner Orifice (60 Hz Only)
	140821	3	#28 Natural Gas Burner Orifice (50 Hz Only)
	140808	3	#44 Liquid Propane Gas Burner Orifice (50 Hz Only)
11	141232	1	1/2" Direct Spark Ignition Manifold (3-Port)
12	318700	2	Pipe Bracket (bent)
13	150300	4	#10 x 1/2" Hex Washer TEK Screw
14	128927	1	1/2" 24 VAC Redundant (natural gas) Gas Valve
	880960	1	1/2" 24 VAC Redundant (liquid propane gas) Gas Valve
	140411	1	1/2" Valve Conversion Kit (liquid propane gas)
15	318712	1	GV Pipe Bracket (for models mfd. as of August 10, 1995)
16	150309	2	#10-16 x 1/2" Phillips Round Head Crimptite (for models mfd. as of August 10, 1995)
17	881367	1	1/2" Union Shut Off with Tail Piece
18	142809	1	1/2" x 29-1/8" Pipe
19	150299	2	#10 x 1" Hex Washer TEK Screw
20	128935	1	Johnson Controls Direct Spark Ignition Module (blue) For Models Mfd. as of April 15, 2000
	880815	1	ADC Direct Spark Ignition Module Only (50/60 Hz) (white)
21	850899	1	Non-Heat Reclaimer Burner Box Only
---	809627**	1	Natural Gas Burner Assembly Complete Less Orifices
---	809628**	1	Liquid Propane Gas Burner Assembly Complete Less Orifices
---	880984*	1	Super AD-50 Liquid Propane Conversion Kit (60 Hz models)
---	880985*	1	Super AD-50 Liquid Propane Conversion Kit (50 Hz models)

* Consult factory for elevations over 2,000 feet.

** Orifices *are not included* and **must be** ordered separately.

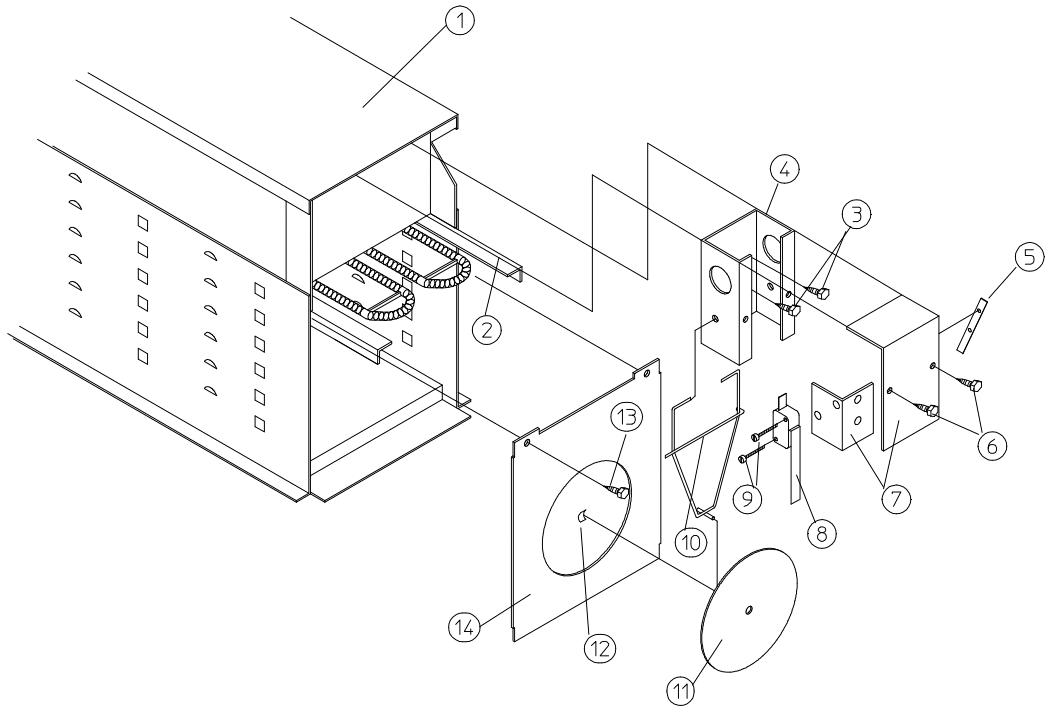

ELECTRIC OVEN (FRONT VIEW)

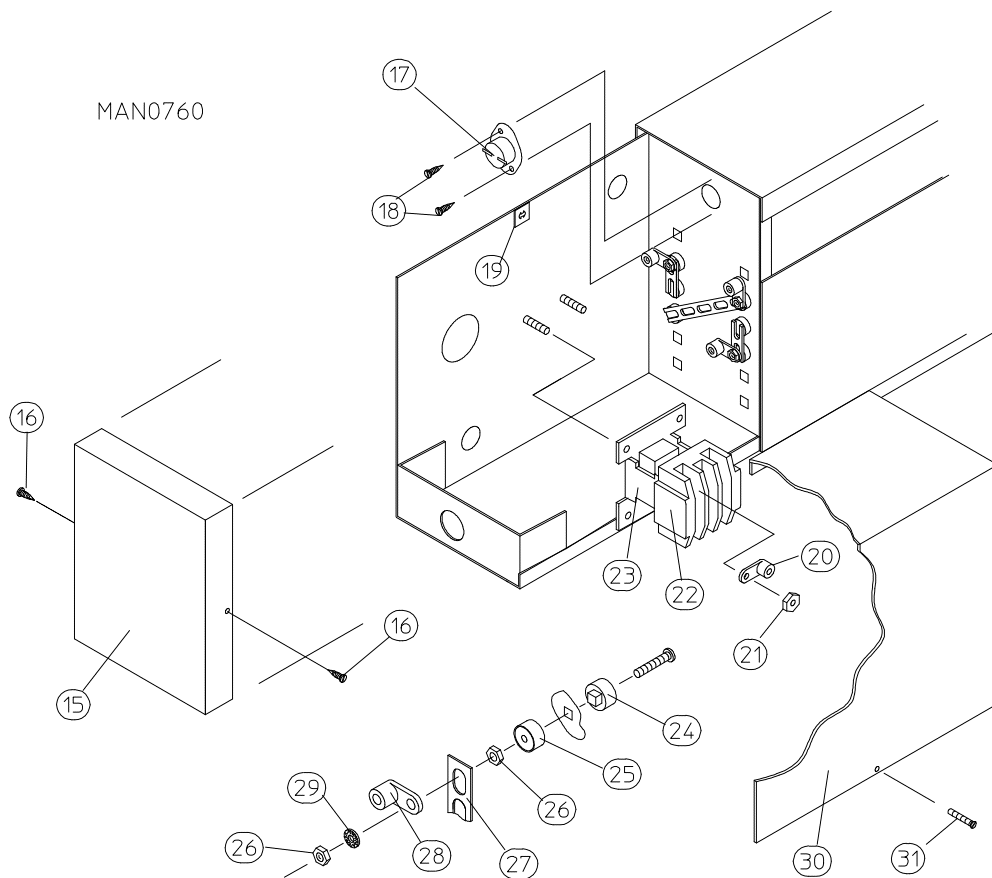

MAN0760

Electric Oven Assembly

<u>Illus. No.</u>	<u>Part No.</u>	<u>Qty.</u>	<u>Description</u>
1	803007*	1	Large Electric Oven Box Only
	-----*	1	Electric Oven Assembly Complete
2	-----*	-	Electric Element
3	150300	2	#10 x 1/2" Hex Washer TEK Screw
4	802800	1	Sail Switch Box with Cover and Bracket Only
	802801	1	Sail Switch Box Assembly Complete (includes illus. nos. 4 through 12)
5	154004	1	Twin Speed Nut
6	150309	2	#10-16 x 1/2" Hex Head TEK Crimptite Screw
7	802799	1	Sail Switch Box Cover Only
8	122200	1	Sail Switch
9	150303	2	#4 x 3/4" Pan Head "A" Machine Screw
10	105500	1	Sail Switch Actuator Rod
11	319202	1	Sail Switch Damper (flat)
12	154002	1	1/8" Push On Fastener
13	150300	2	#10 x 1/2" Hex Washer TEK Screw
14	803100	1	Electric Oven Front Cover Only
15	320611	1	Large Relay Box Cover Only
16	150402	2	#10-24 x 5/8" Slotted Truss Head Machine Screw
17	130400	1	290° Hi-Limit
18	150300	2	#10 x 1/2" Hex Washer TEK Screw
19	154001	1	#10-24 Speed Nut
20	121010	1	L-70 Ground Lug
21	152014	3	1/4-20 Free Spin Wash Nut
22	-----*	1	Oven Relay
23	-----*	1	Oven Relay Replacement Coil
24	120081	-	Internal Ceramic Insulator (2 per element)
25	120080	-	External Ceramic Insulator (2 per element)
26	152008	-	#10-32 Hex Nut (4 per element)
27	121011*	-	Bus Bar (sold by the foot)
28	-----*	-	Terminal Lug
29	153009	-	#10 Star Washer (2 per element)
30	320607	1	Large Electric Oven Right Side Cover Only
31	150402	2	#10-24 x 5/8" Slotted Truss Head Machine Screw

* Refer to **Electric Oven Chart** on **page 46**.

Steam Coil / Air Operated Steam Damper Assembly

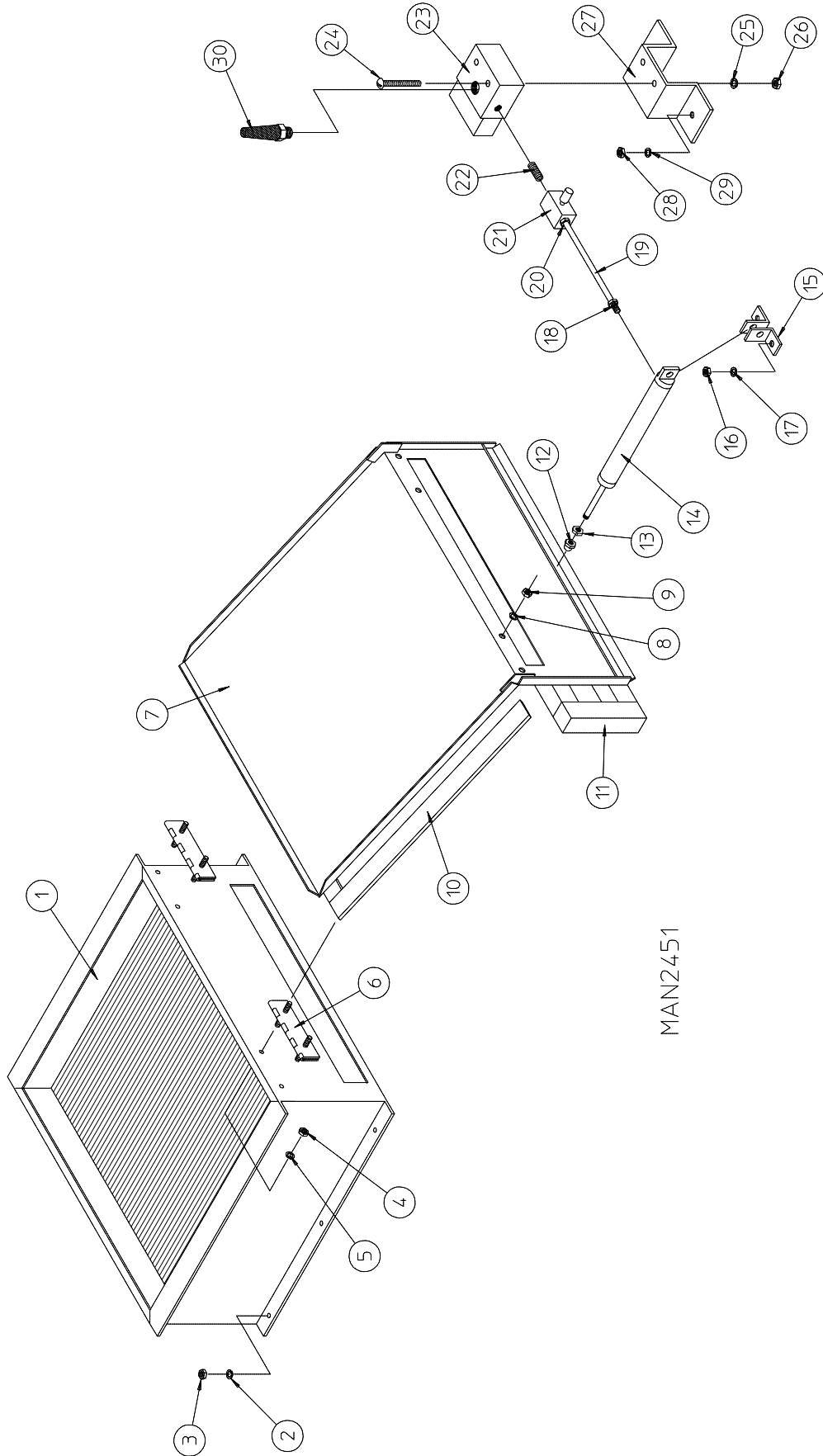

MAN2451

Steam Coil / Air Operated Steam Damper Assembly

<u>Illus. No.</u>	<u>Part No.</u>	<u>Qty.</u>	<u>Description</u>
1	165009	1	Steam Coil Assembly
2	153002	6	5/16" Lock Washer
3	152004	6	5/16-18 Hex Nut
4	152002	4	1/4-20 Hex Nut
5	153007	4	1/4" Lock Washer
6	820321	2	Steam Damper Hinge Assembly
7	803415	1	Steam Damper Assembly (includes illus. nos. 7, 10, and 11)
8	153007	4	1/4" Lock Washer
9	152002	4	1/4-20 Hex Nut
10	115995	60	Steam Damper Gasket (sold by the inch)
11	102350	1	68-1/2" Long Steam Damper Foam Gasket
12	151007	1	7/16-20 Stainless Steel Acorn Nut
13	152007	1	7/16-20 Hex Nut
14	100497	1	1-1/4" x 3" Stroke Piston
15	100492	1	Piston Support Bracket
16	152002	2	1/4-20 Hex Nut
17	153007	2	1/4" Lock Washer
18	100472	1	1/4" Poly x 1/8" M.P.T. Connector
19	143110	1	1/4" Poly Flo Tubing (sold by the foot)
20	100472	1	1/4" Poly x 1/8" M.P.T. Connector
21	100496	1	1/8" Needle Valve
22	143238	1	1/8" Brass Close Nipple
23	100498	1	3-Way Micro Valve 24 VAC
24	150002	2	#6-32 x 1" Machine Bolt
25	153010	2	#6 Star Washer
26	152000	2	#6-32 Hex Nut
27	330987	1	Micro Valve Support
28	152002	2	1/4-20 Hex Nut
29	153007	2	1/4" Lock Washer
30	100520	1	1/8" N.P.T. Silencer (muffler)

Sail Switch / Hi-Limit Assembly

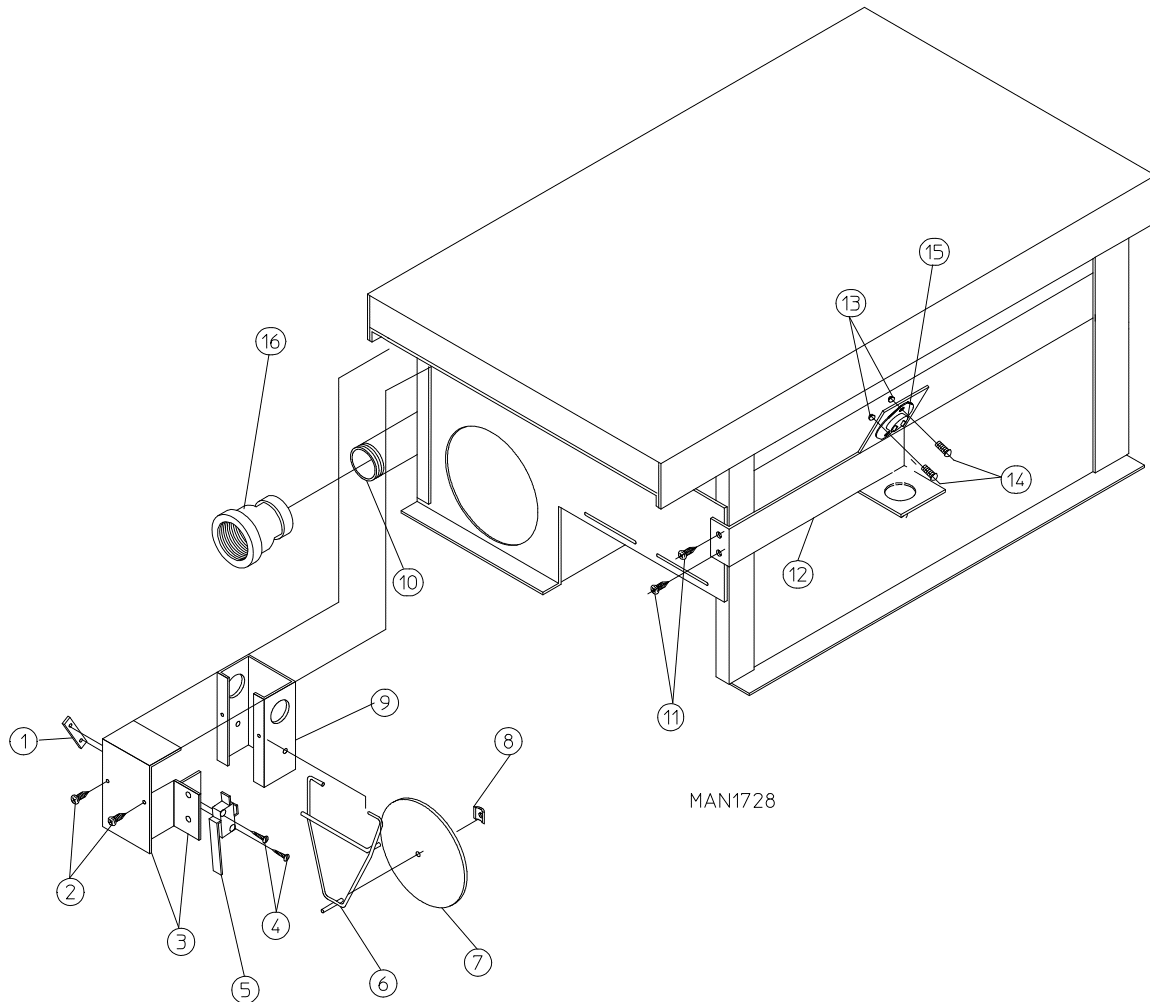

<u>Illus. No.</u>	<u>Part No.</u>	<u>Qty.</u>	<u>Description</u>
1	154004	1	Twin Speed Nut
2	150309	2	#10-16 x 1/2" Hex Head TEK Crimptite Screw
3	802799	1	Sail Switch Box Cover and Bracket Only
4	150303	2	#4 x 3/4" Pan Head "A" Machine Screw
5	122200	1	Sail Switch Only
6	105500	1	Sail Switch Actuator Rod
7	319202	1	Sail Switch Damper (flat)
8	154002	1	1/8" Push On Fastener
9	802800	1	Sail Switch Box with Cover and Bracket Only
	802801	1	Sail Switch Assembly Complete (includes illus. nos. 1 through 8)
10	142809	1	1/2" x 29-1/8" Pipe
11	150309	2	#10-16 x 1/2" Round Head Machine Screw
12	319704	1	Hi-Limit Mounting Bracket Only
13	151000	2	#6-32 Pal Nut
14	151001	2	#6-32 x 1/2" Round Head Machine Screw
15	130403	1	330° Hi-Limit (automatic reset)
	130201	1	330° Hi-Limit (manual reset)
16	143000	1	1/2" x 3/4" Reducing Coupling

Single-Phase (1Ø) Motor, Electric Relay Panel Assembly

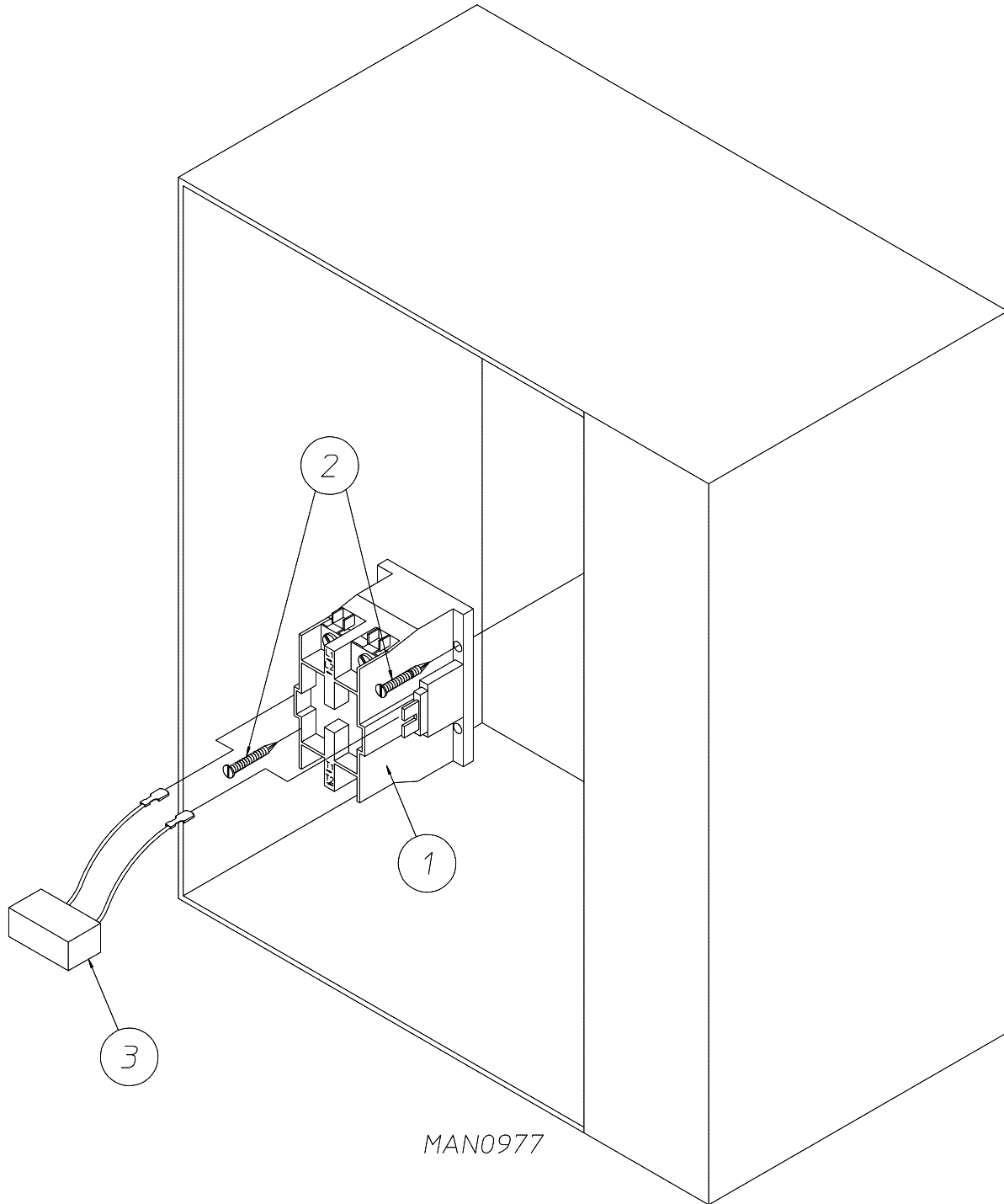

<u>Illus. No.</u>	<u>Part No.</u>	<u>Qty.</u>	<u>Description</u>
1	132475	1	2-Pole Contactor 24 VAC
2	150299	2	#10 x 1" Hex Head Screw
3	824828	1	RC Network with Connectors (for microprocessor controlled models Only)
-	322809	1	Back Electrical Box Cover...Not Illustrated
-	150301	4	#8-18 x 7/16" Phillips Pan Head TEK Screw...Not Illustrated

3-Phase (3Ø) Motor, Electric Relay Panel Assembly

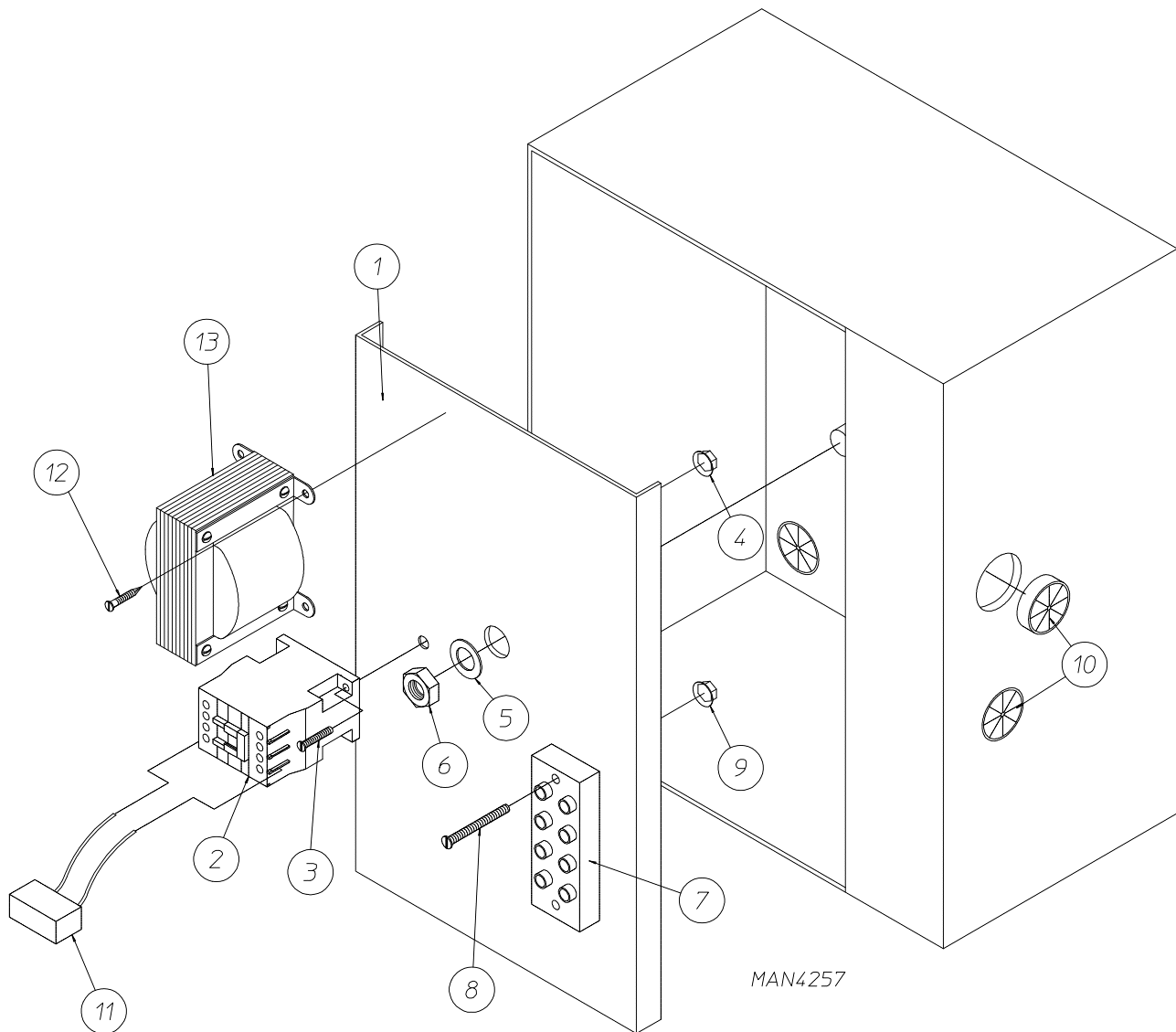

<u>Illus. No.</u>	<u>Part No.</u>	<u>Qty.</u>	<u>Description</u>
1	322812	1	Back Electrical Box Component Plate
2	132430	1	Impellor Contactor (208/230/240v, 50/60 Hz) 24v Coil
3	150103	2	#8-32 x 3/4" Phillips Round Head Machine Screw
4	151001	2	#8-32 Pal Nut
5	153002	1	5/16-18 Lock Washer
6	152004	1	5/16-18 Hex Nut
7	120701	1	4-Position Terminal Block
8	150008	2	#6-32 x 1-1/4" Slotted Round Head Machine Screw
9	151000	2	#6-32 Pal Nut
10	121300	3	Open/Closed Bushing
11	137015	1	RC Filter (for microprocessor controlled models Only)
12	150300	2	#10 x 1/2" Hex Washer TEK Screw
13	-----	-	Transformer (refer to Transformer Listings on page 47 and page 48)
--	322809	1	Back Electrical Box Cover...Not Illustrated
--	150301	4	#8-18 x 7/16" Phillips Pan Head TEK Screw...Not Illustrated

Microprocessor Reversing Rear Control Box Assembly

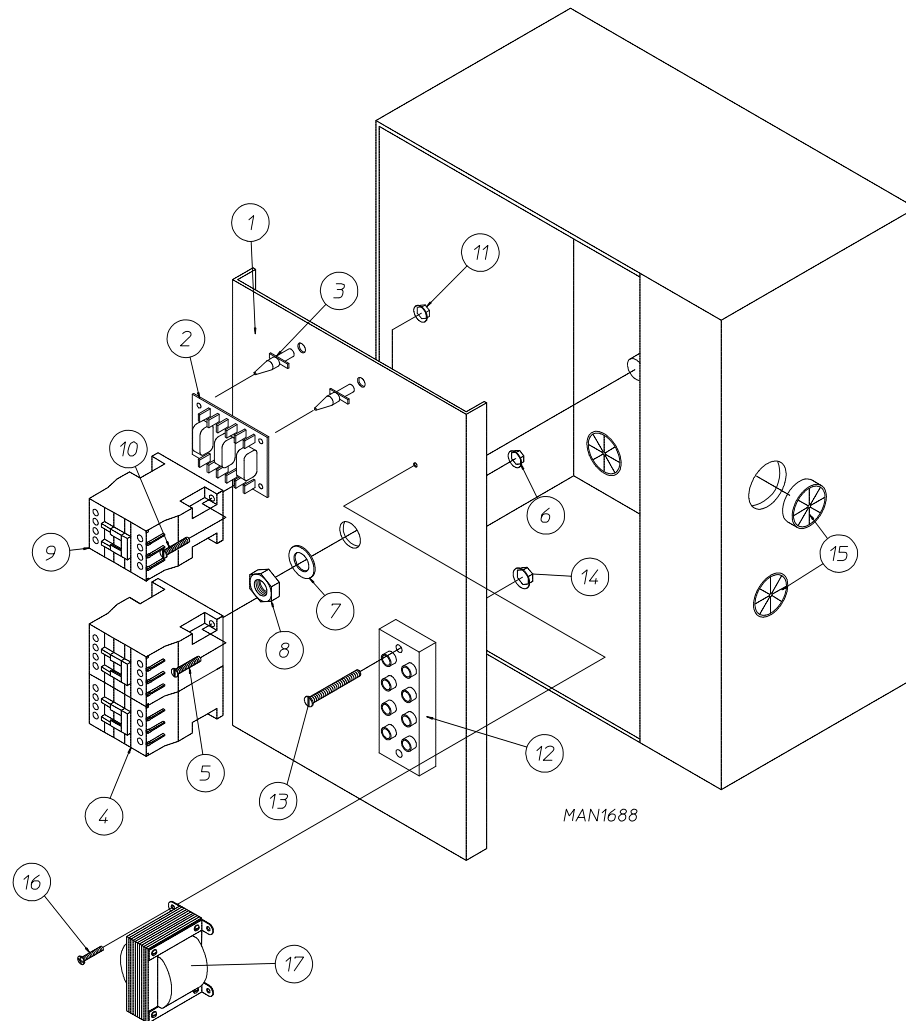

<u>Illus. No.</u>	<u>Part No.</u>	<u>Qty.</u>	<u>Description</u>
1	322812	1	Back Electrical Box Component Plate
2	137060	1	Arc Suppressor Board
3	137013	4	Nylon Standoff
4	882386	1	Reversing Contactor (208/230/240v, 50/60 Hz) 24v Coil
5	150103	2	#8-32 x 3/4" Phillips Round Head Machine Screw
6	151001	2	#8-32 Pal Nut
7	153002	1	5/16-18 Lock Washer
8	152004	1	5/16-18 Hex Nut
9	132430	1	Impellor Contactor (208/230/240v, 50/60 Hz) 24v Coil
10	150103	2	#8-32 x 3/4" Phillips Round Head Machine Screw
11	151001	2	#8-32 Pal Nut
12	120701	1	4-Position Terminal Block
13	150008	2	#6-32 x 1-1/4" Slotted Round Head Machine Screw
14	151000	2	#6-32 Pal Nut
15	121300	3	Open/Closed Bushing
16	150300	2	#10 x 1/2" Hex Washer TEK Screw
17	-----	-	Transformer (refer to Transformer Listings on page 47 and page 48)
--	322809	1	Back Electrical Box Cover...Not Illustrated
--	150301	4	#8-18 x 7/16" Phillips Pan Head TEK Screw...Not Illustrated

Dual Timer Reversing Rear Control Box Assembly

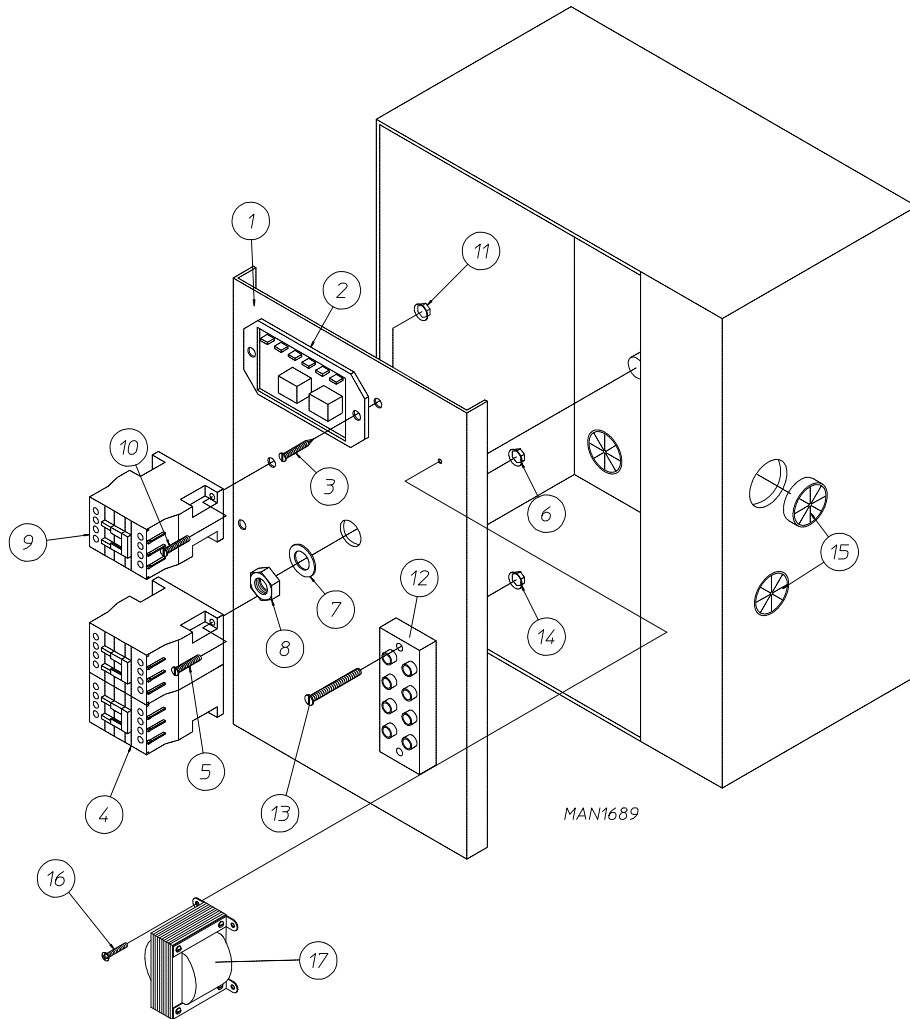

<u>Illus. No.</u>	<u>Part No.</u>	<u>Qty.</u>	<u>Description</u>
1	322812	1	Back Electrical Box Component Plate
2	132198	1	Reversing Timer 24v 50/60 Hz
3	150301	2	#8-18 x 7/16" Phillips Pan Head TEK Screw
4	882386	1	Reversing Contactor (208/230/240v, 50/60 Hz) 24v Coil
5	150103	2	#8-32 x 3/4" Phillips Round Head Machine Screw
6	151001	2	#8-32 Pal Nut
7	153002	1	5/16-18 Lock Washer
8	152004	1	5/16-18 Hex Nut
9	132430	1	Impellor Contactor (208/230/240v, 50/60 Hz) 24v Coil
10	150103	2	#8-32 x 3/4" Phillips Round Head Machine Screw
11	151001	2	#8-32 Pal Nut
12	120701	1	4-Position Terminal Block
13	150008	2	#6-32 x 1-1/4" Slotted Round Head Machine Screw
14	151000	2	#6-32 Pal Nut
15	121300	3	Open/Closed Bushing
16	150300	2	#10 x 1/2" Hex Washer TEK Screw
17	-----	-	Transformer (refer to Transformer Listings on page 47 and page 48)
--	322809	1	Back Electrical Box Cover...Not Illustrated
--	150301	4	#8-18 x 7/16" Phillips Pan Head TEK Screw...Not Illustrated

Outer Top / Back Guard Assemblies

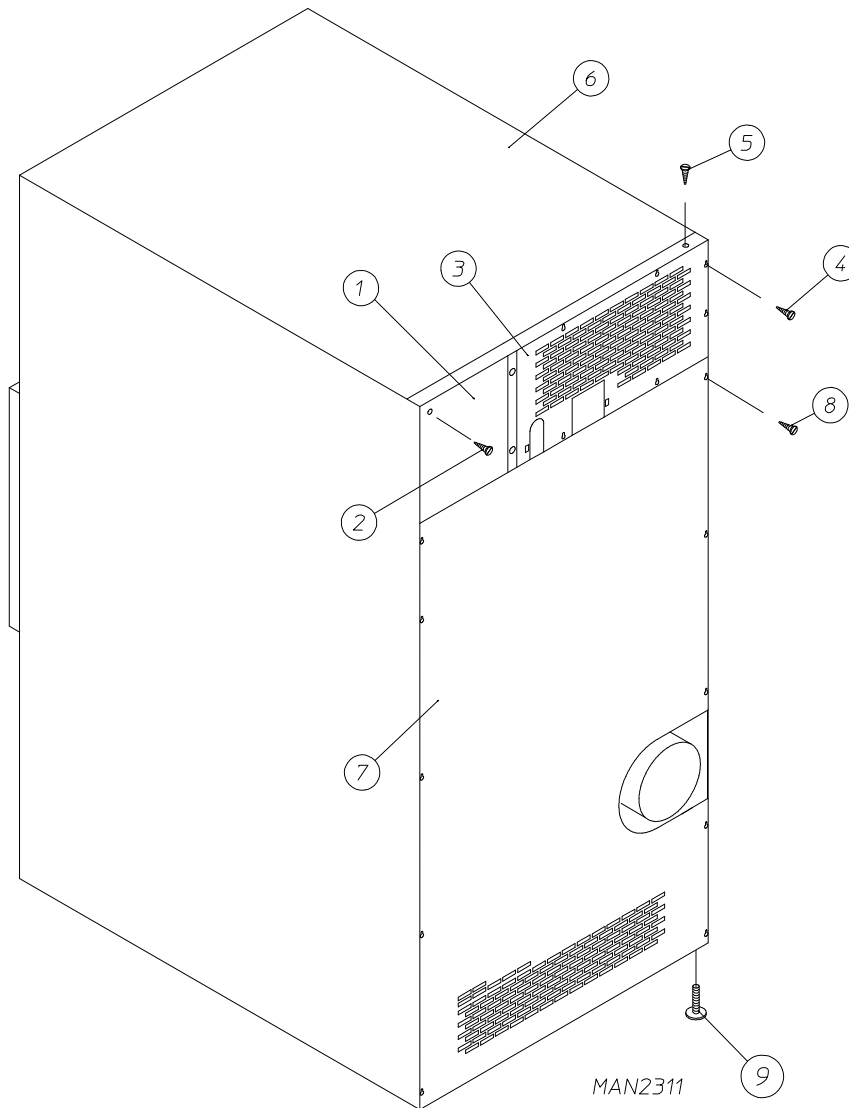

<u>Illus. No.</u>	<u>Part No.</u>	<u>Qty.</u>	<u>Description</u>
1	322809	1	Back Electrical Box Cover
2	150301	4	#8-18 x 7/16" Phillips Pan Head TEK Screw
3	314421	1	Top Back Guard (gas models Only) (for models mfd. as of April 20, 1998)
	314422	1	Top Back Guard (electric models Only) (for models mfd. as of April 20, 1998)
	314411	1	Top Back Guard (for models mfd. prior to April 20, 1998) No Top Back Guard on Steam Models
4	150301	7	#8-18 x 7/16" Phillips Pan Head TEK Screw
5	150301	10	#8-18 x 7/16" Phillips Pan Head TEK Screw
6	801577	1	Outer Top (electric models Only)
	312533	1	Outer Top (gas models Only) No Outer Top on Steam Models
7	314523	1	Bottom Back Guard (plain)
8	150301	13	#8-18 x 7/16" Phillips Pan Head TEK Screw
9	103500	4	Leveling Legs

SUPER AD-50

kW	Volt	Phase	Wire	Oven Assembly	Element			Oven Wire			Terminal Lug		Bus Bar	Oven Relay	
					Qty.	kW	Part #	Qty.	Size	Part #	Qty.	Part #	121011	Cat #	Part #
48	208	3Ø	3 or 4	881624	6	8	120051	5	#4	133300	6	121010	1	DPA63	131369*
48	240	3Ø	3	--	--	--	--	--	--	--	--	--	--	--	--
48	380	3Ø	3 or 4	--	--	--	--	--	--	--	--	--	--	--	--
48	416	3Ø	3 or 4	--	--	--	--	--	--	--	--	--	--	--	--
48	460/480	3Ø	3 or 4	--	--	--	--	--	--	--	--	--	--	--	--
42	208	3Ø	3 or 4	824092	6	7	120034	5	#6	133200	6	121010	1	DPA63	131369*
42	240	3Ø	3	881630	6	7	120035	5	#2	133302	5	121012	1	GEAJ	131385
42	380	3Ø	3 or 4	--	--	--	--	--	--	--	--	--	--	--	--
42	416	3Ø	3 or 4	--	--	--	--	--	--	--	--	--	--	--	--
42	460/480	3Ø	3 or 4	--	--	--	--	--	--	--	--	--	--	--	--
40	208	3Ø	3 or 4	--	--	--	--	--	--	--	--	--	--	--	--
40	240	3Ø	3	--	--	--	--	--	--	--	--	--	--	--	--
40	380	3Ø	3 or 4	--	--	--	--	--	--	--	--	--	--	--	--
40	416	3Ø	3 or 4	824922	6	6.6	120027	4	#6	133200	6	121010	1	DFAJ	131361
40	460/480	3Ø	3 or 4	--	--	--	--	--	--	--	--	--	--	--	--
36	208	3Ø	3 or 4	824921	6	6	120015	4	#2	133302	8	121012	1	GEAJ	131385
36	240	3Ø	3	824920	6	6	120014	4	#2	133302	6	121010	1	FEAJ	131375
36	380	3Ø	3 or 4	--	--	--	--	--	--	--	--	--	--	--	--
36	416	3Ø	3 or 4	824921	6	6	120015	4	#2	133302	3	121012	1	DFAJ	131361
36	460/480	3Ø	3 or 4	824920	6	6	120014	4	#2	133302	6	121010	1	CEAJ	131357
30	208	3Ø	3 or 4	824917	6	5	120012	3	#4	133300	5	121012	1	DPA43	131357
30	240	3Ø	3	824934	6	5	120013	3	#4	133300	5	121012	1	EEAJ	131369
30	380	3Ø	3 or 4	824976	6	5	120000	4	#8	133100	6	121010	2	FEAJ	131375
30	416	3Ø	3 or 4	824949	6	5	120012	4	#8	133100	6	121010	2	DPA43	131357
30	480	3Ø	3 or 4	824955	6	5	120013	4	#8	133100	6	121010	2	DPA43	131357
44	460	3Ø	3	824003	8	6	120052	4	#2	133302	6	121010	1	DEAJ	131352

* Quantity of two required for this oven.

NOTE: Information not listed was not available at time of printing contact factory.

Super AD-50				
Heat	Voltage	Wire Service	Stepdown Transformer Part No.	Control Voltage Part No.
Gas <hr style="width: 50%; margin: 0 auto;"/> Steam	208-240	3 or 4	---	141403
	380	3	132059	141403
	380	4	132059	141403
	416	3	132062	141403
	416	4	132062	141403
	460/480	3	132053	141403
	460/480	4	132053	141403
	575	3	132050	141403

SUPER AD-50

Kw	Volt	Phase	Wire	Stepdown Transformer Part No.	Control Voltage Transformer Part No.
48	208	3Ø	3 or 4	--	132070
48	240	3Ø	3	--	132070
48	380	3Ø	3 or 4	132059	132070
48	416	3Ø	3 or 4	132062	132070
48	460/480	3Ø	3 or 4	132053	132070
42	208	3Ø	3 or 4	--	--
42	240	3Ø	3	--	--
42	380	3Ø	3 or 4	--	--
42	416	3Ø	3 or 4	--	--
42	460/480	3Ø	3 or 4	--	--
40	208	3Ø	3 or 4	--	--
40	240	3Ø	3	--	--
40	380	3Ø	3 or 4	132059	141403
40	416	3Ø	3 or 4	132062	141403
40	460/480	3Ø	3 or 4	132053	141403
36	208	3Ø	3 or 4	--	132070
36	240	3Ø	3	--	132070
36	380	3Ø	3 or 4	132059	141403
36	416	3Ø	3 or 4	132062	141403
36	460/480	3Ø	3 or 4	132053	141403
30	208	3Ø	3 or 4	--	132070
30	240	3Ø	3	--	132070
30	380	3Ø	3 or 4	132059	141403
30	416	3Ø	3 or 4	132062	141403
30	480	3Ø	3 or 4	132053	141403

NOTE: Information not listed was not available at time of printing contact factory.

Microprocessor Coin Acceptors Listing

NOTE: Coin acceptors listed include optical switch (ADC Part No. 137056 Greenwald).
Coin acceptors listed include optical switch (ADC Part No. 881143 Hanke).

Single Coin*

<u>ADC Part No.</u>	<u>Nation</u>	<u>Description</u>
882689	United States	25¢ Hanke Optic Coin Acceptor (for models mfd. as of July 26, 2000)
125100	U.S. and Canada	25¢ Greenwald Optic Coin Acceptor (for models mfd. prior to July 26, 2000)
125107	Australia	20¢ Greenwald Australian Optic Coin Acceptor
881768	Australia	\$1 Hanke Australian Optic Coin Acceptor
881604	Japan	100 Yen Hanke Optic Coin Acceptor
125103	---	0.882 Greenwald Token Optic Coin Acceptor
125121	---	0.800 Greenwald Token Optic Coin Acceptor
125133	Hong Kong	\$1 Hong Kong Optic Coin Acceptor

Dual Coin*

<u>ADC Part No.</u>	<u>Nation</u>	<u>Description</u>
881508	U.S. and Canada	10¢/25¢ Hanke Dual Optic Coin Acceptor
881842	Canada	25¢/\$1 Hanke Dual Optic Coin Acceptor
881542	United Kingdom	1£/20 Pence Hanke Dual Optic Coin Acceptor
881846	France	2/5 French Franc Hanke Dual Optic Coin Acceptor
881541	Netherlands	25¢/1 Hanke Guilder Dual Optic Coin Acceptor

* Consult factory for coin acceptors not listed.

<u>Part Number</u>	<u>Description</u>
112039	“Black/White/Green Ground” Label
112280	“Clean Lint Screen” Label
112534	“Phase 5 Non-Coin Program Location Summary” Label
112533	“Phase 5 Coin Program Location Summary” Label
114001	“CAUTION – Exhaust/Lint Screen” Label
114006	“WARNING – Fire Hazards” Label
120800	1/4” In-Line Connector
120802	Red Butt Connector
120902	#74B Wire Nut
120903	Crimp-on Wire Nut
121006	#10 Insulated Ring Terminal
121014	1/4” Insulated (Female) Terminal
121026	Tab Receptacle Combination
121499	5-1/2” Harness Tie
121500	8” Harness Tie
121503	Harness Tie Mounting Clip
122804	Manometer (water column test gauge)
404500	Almond Brush-in-Cap Bottle Touch-Up Paint
404502	White Brush-in-Cap Bottle Touch-Up Paint
404506	Beige Brush-in-Cap Bottle Touch-Up Paint
404507	Cornflower Blue Brush-in-Cap Bottle Touch-Up Paint

