

Washer-Extractor

Pocket Hardmount
UWPV

Refer to Page 8 for Model Numbers

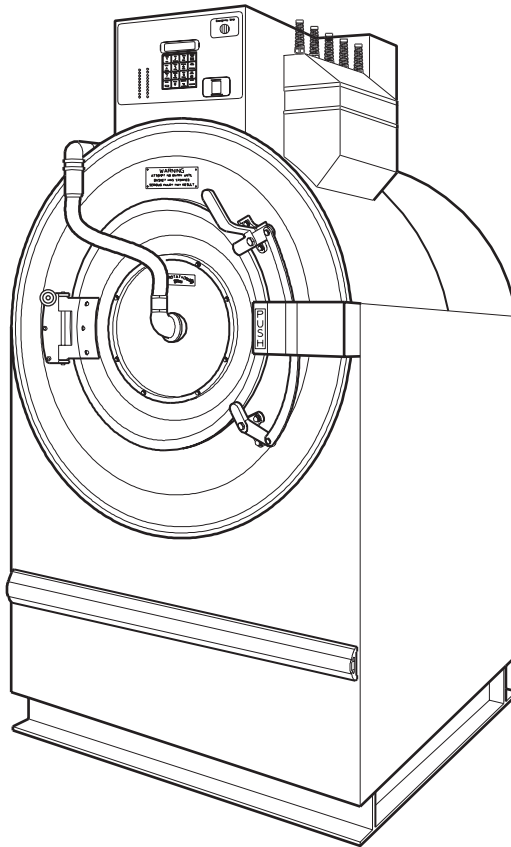

PHM1380C

Service

Table of Contents

Section 1 – Safety Information

General Safety Precautions	3
Important Safety Instructions	4
Locating an Authorized Servicer	6

Section 2 – Introduction

Customer Service	7
Nameplate Location	7
Model Identification	8

Section 3 – Installation

Electrical Installation	10
Mechanical & Electrical Design	11
Component Function.....	11

Section 4 – Troubleshooting

1. WE-6 Control Has No Visible Display — P and N-Voltage Models	14
2. WE-6 Control Has No Visible Display — Q-Voltage Model	18
3. No Fill Analysis	22
4. Water Runs Continuously into the Washer-Extractor	26
5. Door Lock Switch Analysis	30
6. No Fuseboard Functions	34
7. No Motor Operation (With No AC Drive Fault)	38
Preliminary Checks:.....	38
Secondary Checks:.....	38
A-B 160 Control Logic	38
A-B 1305 Control Logic	39
A-B 1336 Control Logic	40
8. No Motor Operation (With AC Drive Fault)	46
9. The Motor is Running, but at an Abnormal Speed	47
Preliminary Checks:.....	47
Secondary Checks:.....	47
AC Drive Fault Codes and Troubleshooting Information.....	48
10. No Spin	50
11. Fill Alarm Analysis	51
12. Empty Alarm Analysis	54
13. Automatic Supply Dispenser Analysis	58
14. No Keypad Functions	59
15. Door Unlocking Function	60
16. Excessive Cycle Time	64

17. Excessive Vibration and/or Noise During Spin	65
18. Stop/Done Situation in Mid Cycle	65
19. Power Wait Situation in Mid Cycle	65
20. Pumps Turning on in Mid Cycle Without Being Programmed to Do So	65

Section 5 – Service Procedures

21. Voltage Distribution	67
22. Electrical Testing	69
23. Computer Test Procedure	71
Test equipment required:.....	71
Computer Test Procedure.....	71
24. Test cycle	72
If the display indicates a “DOOR” alarm.....	72
If the display indicates a “WATER” alarm..	72
If the display indicates a “FILL” alarm	72
If the display indicates an “EMPTY” (empty) alarm.....	72
If there is no spin, but the rest of the program is OK.....	73
If the basket goes into spin with water left in the basket	73
If the display indicates “OVERHT”	73
If the display indicates a “TEMP” alarm	73
If the display indicates a “MEMR” alarm....	73
25. Keypad Removal and Installation	73
26. Computer Board Removal and Installation	76
27. Fuse Board Removal and Installation	76
28. Interface Board Removal and Installation	77
29. Keypmode Switch	78
30. Calibrating the WE-6 Temperature Circuit	78
31. AC Drive Removal and Installation	80
32. Drive Motor	81
Service Tips.....	81
Removal	81
Installation.....	82
33. Drive Belt	82
Belt Replacement:.....	82
Checking Belt Tension and Deflection:.....	83
34. Water Level Pressure Switch	84
Service Tips.....	84
Removal and Installation	85
35. Water Valve	85
36. Drain Valve	86

(continued)

© Copyright 2003, Alliance Laundry Systems LLC

All rights reserved. No part of the contents of this book may be reproduced or transmitted in any form or by any means without the expressed written consent of the publisher.

37. Flange Relay Removal and Installation	86
38. Vacuum Breaker	87
39. Door Gasket Removal and Installation	87
40. Bearings and Cartridge Seal Replacement	88
Mounting Instructions	92
41. Bearing Alignment	95
Bearing Troubleshooting Tips.....	95

Section 1

Safety Information

Throughout this manual and on machine decals, you will find precautionary statements (“CAUTION,” “WARNING,” and “DANGER”) followed by specific instructions. These precautions are intended for the personal safety of the operator, user, servicer and those maintaining the machine.

▲ DANGER

Danger indicates the presence of a hazard that **will** cause **severe** personal injury, death or substantial property damage if the danger is ignored.

▲ WARNING

Warning indicates the presence of a hazard that **can** cause **severe** personal injury, death or substantial property damage if the warning is ignored.

▲ CAUTION

Caution indicates the presence of a hazard that **will** or **can** cause **minor** personal injury or property damage if the caution is ignored.

Additional precautionary statements (“IMPORTANT” and “NOTE”) are followed by specific instructions.

IMPORTANT

The word “IMPORTANT” is used to inform the reader of specific procedures where minor machine damage will occur if the procedure is not followed.

NOTE

The word “NOTE” is used to communicate installation, operation, maintenance or servicing information that is important but not hazard related.

General Safety Precautions

In the interest of safety, some general precautions relating to the operation of this machine follow.

	WARNING
<ul style="list-style-type: none">• Failure to install, maintain and/or operate this product according to the manufacturer’s instructions may result in conditions which can produce serious injury, death and/or property damage.• Do not repair or replace any part of the product or attempt any servicing unless specifically recommended or published in this Service Manual and unless you understand and have the skills to carry out the servicing.• Whenever ground wires are removed during servicing, these ground wires must be reconnected to ensure that the product is properly grounded and to reduce the risk of fire, electric shock, serious injury or death.	
<small>W006R2</small>	

(continued)



WARNING

To reduce the risk of electric shock, fire, explosion, serious injury or death:

- Disconnect electric power to the washer-extractor before servicing.
- Never start the washer-extractor with any guards/panels removed.
- Whenever ground wires are removed during servicing, these ground wires must be reconnected to ensure that the washer-extractor is properly grounded.

W460



WARNING

Repairs that are made to your products by unqualified persons can result in hazards due to improper assembly or adjustments subjecting you or the inexperienced person making such repairs to the risk of serious injury, electrical shock or death.

W007



WARNING

If you or an unqualified person perform service on your product, you must assume the responsibility for any personal injury or property damage which may result. The manufacturer will not be responsible for any injury or property damage arising from improper service and/or service procedures.

W008

Always contact your dealer, distributor, service agent or the manufacturer about any problems or conditions you do not understand.

Important Safety Instructions



WARNING

To reduce the risk of fire, electric shock, serious injury or death to persons when using your washer, follow these basic precautions:

W023E

1. Read all instructions before using the washer-extractor.
2. Refer to the GROUNDING INSTRUCTIONS in the INSTALLATION manual (supplied with your washer-extractor) for the proper grounding of the washer-extractor.
3. Do not wash textiles that have been previously cleaned in, washed in, soaked in or spotted with gasoline, dry-cleaning solvents or other flammable or explosive substances. They give off vapors that could ignite or explode.
4. Do not add gasoline, dry-cleaning solvents or other flammable or explosive substances to the wash water. These substances give off vapors that could ignite or explode.
5. Under certain conditions, hydrogen gas may be produced in a hot water system that has not been used for two weeks or more. HYDROGEN GAS IS EXPLOSIVE. If the hot water system has not been used for such a period, before using a washer-extractor, turn on all hot water faucets and let the water flow from each for several minutes. This will release any accumulated hydrogen gas. The gas is flammable. Do not smoke or use an open flame during this time.

6. Do not allow children to play on or in a washer-extractor. Close supervision of children is necessary when the washer-extractor is used near children.
7. Before the washer-extractor is removed from service or discarded, remove the door to the washing compartment.
8. Do not reach into the washer-extractor if the wash basket is moving.
9. Do not install or store the washer-extractor where it will be exposed to water and/or weather.
10. Do not tamper with the washer-extractor's controls.
11. Do not repair or replace any part of the washer-extractor or attempt any servicing unless specifically recommended in the user-maintenance instructions or in published user-repair instructions that the user understands and has the skills to carry out.
12. To reduce the risk of an electrical shock or fire, DO NOT use an extension cord or an adapter to connect the washer-extractor to an electrical power source.
13. Use the washer-extractor only for its intended purpose, washing clothes.
14. ALWAYS disconnect the washer-extractor from its electrical supply before attempting any service.
15. Install the washer-extractor according to the INSTALLATION INSTRUCTIONS. All connections for water, drain, electrical power and grounding must comply with local codes and, when required, be made by licensed personnel.
16. To reduce the risk of fire, textiles which have traces of any flammable substances such as vegetable oil, cooking oil, machine oil, flammable chemicals, thinner, etc. or anything containing wax or chemicals such as in mops or cleaning cloths, must not be put into the washer-extractor. These flammable substances may cause the fabric to ignite.
17. Do not use fabric softeners or products to eliminate static unless recommended by the manufacturer of the fabric softener or product.
18. Keep the washer-extractor in good condition. Bumping or dropping the washer-extractor can damage its safety features. If this occurs, have the washer-extractor checked by a qualified service person.
19. Replace worn power cords and/or loose plugs.
20. Be sure that water connections have a shut-off valve and that fill hose connections are tight. CLOSE the shut-off valves at the end of each wash day.
21. The loading door MUST BE CLOSED any time the washer-extractor is to fill, tumble or spin. DO NOT bypass the loading door switch and permit the washer-extractor to operate with the loading door open.
22. Always read and follow the manufacturer's instructions on packages of laundry and cleaning aids. Heed all warnings and precautions. To reduce the risk of poisoning or chemical burns, keep them out of the reach of children at all times (preferably in a locked cabinet).
23. Always follow the fabric care instructions supplied by the textile manufacturer.
24. Never operate the washer-extractor with any guards and/or panels removed.
25. DO NOT operate the washer-extractor with missing or broken parts.
26. DO NOT by-pass any safety devices.
27. Failure to install, maintain and/or operate this washer-extractor according to the manufacturer's instructions may result in conditions that can produce bodily injury and/or property damage.

NOTE: The WARNING and IMPORTANT SAFETY INSTRUCTIONS appearing in this manual are not meant to cover all possible conditions and situations that may occur. Common sense, caution and care must be exercised when installing, maintaining and operating the washer-extractor.

Any problems or conditions not understood should be reported to the dealer, distributor, service agent or the manufacturer.

Section 1 Safety Information

Locating an Authorized Servicer

Alliance Laundry Systems is not responsible for personal injury or property damage resulting from improper service. Review all service information before beginning repairs.

Warranty service must be performed by an authorized technician, using authorized factory parts. If service is required after the warranty expires, Alliance Laundry Systems also recommends contacting an authorized technician and using authorized factory parts.

Section 2 Introduction

Customer Service

Alliance Laundry Systems is not responsible for personal injury or property damage resulting from improper service. Review all service information before beginning repairs.

If literature or replacement parts are required, contact the source from whom the machine was purchased or contact Alliance Laundry Systems at (920) 748-3950 for the name of the nearest authorized parts distributor.

For technical assistance, call the following number:

(850) 718-1026
Marianna, Florida

Nameplate Location

When calling or writing about your product, be sure to mention model and serial numbers. Model and serial numbers are located on nameplate(s) as shown.

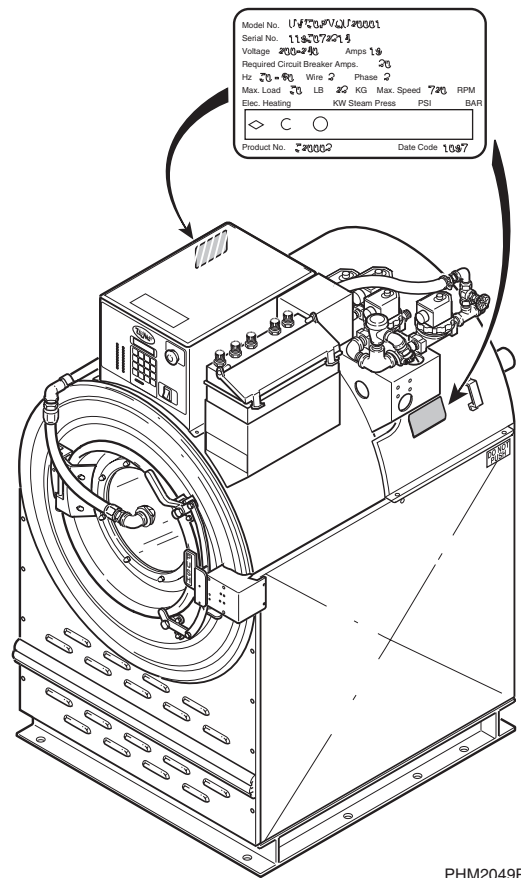

Model Identification

Information in this manual is applicable to these washer-extractors.

UW35PV

UW60PV

UW80PV

UW100PV

UW125PV

Section 3 Installation



WARNING

To reduce the risk of electrical shock, fire, explosion, serious injury or death:

- Disconnect electrical power to the washer-extractor before servicing it.
- Close the gas shut-off valve to the washer-extractor (when applicable) before servicing it.
- Never start the washer-extractor with any guards/panels removed.
- Whenever ground wires are removed during servicing, these ground wires must be reconnected to ensure that the washer-extractor is properly grounded.

W461R1

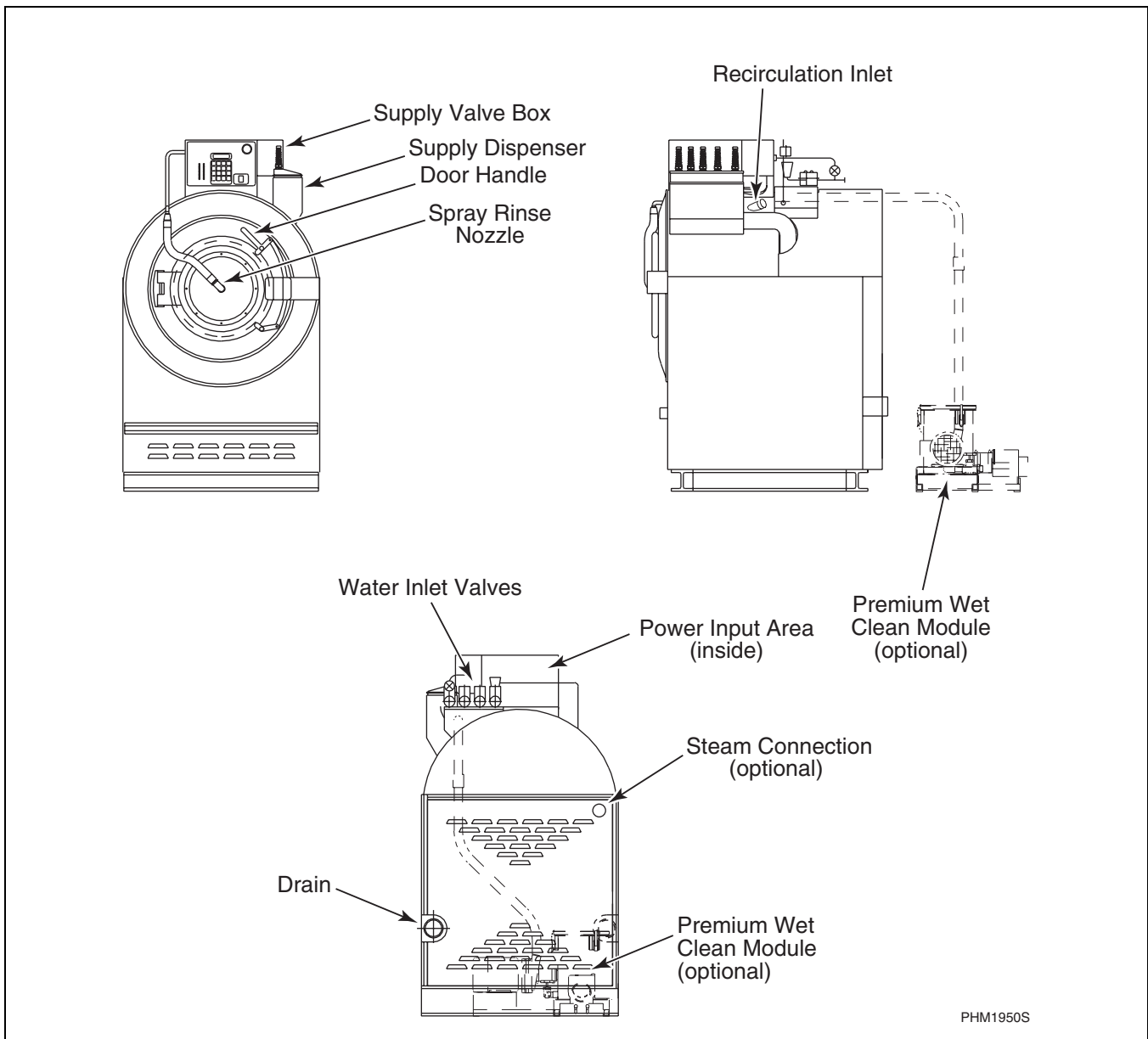



PHM1950S

	<h2 style="margin: 0;">WARNING</h2>
<p>To reduce the risk of electrical shock, fire, explosion, serious injury or death:</p> <ul style="list-style-type: none"> • Disconnect electrical power to the washer-extractor before servicing it. • Close the gas shut-off valve to the washer-extractor (when applicable) before servicing it. • Never start the washer-extractor with any guards/panels removed. • Whenever ground wires are removed during servicing, these ground wires must be reconnected to ensure that the washer-extractor is properly grounded. 	
W461R1	

UWPV Pocket Hardmount Water Supply Line Sizing			
Model	Number of Machines	Supply Line Size, in (mm)	
		Main	Hot/Cold
35	1	1 (25)	3/4 (19)
	2	1-1/2 (38)	1 (25)
	3	2 (50)	1-1/4 (32)
	4	2 (50)	1-1/2 (38)
60	1	1-1/4 (32)	1 (25)
	2	2 (50)	1-1/4 (32)
	3	2 (50)	1-1/2 (38)
	4	2-1/2 (64)	2 (50)
80	1	1-1/4 (32)	1 (25)
	2	2 (50)	1-1/4 (32)
	3	2 (50)	1-1/2 (38)
	4	2-1/2 (64)	2 (50)
100	1	1-1/2 (38)	1 (25)
	2	2 (50)	1-1/2 (38)
	3	2 (50)	2-1/2 (64)
	4	2-1/2 (64)	2 (50)
125	1	2 (50)	1-1/4 (32)
	2	2-1/2 (64)	2 (50)
	3	2-1/2 (64)	2 (50)
	4	2-1/2 (64)	2-1/2 (64)

Electrical Installation

	<h2 style="margin: 0;">WARNING</h2>
<p>This machine must be installed, adjusted and serviced by qualified electrical maintenance personnel familiar with the construction and operation of this type of machinery. They must also be familiar with the potential hazards involved. Failure to observe this warning may result in personal injury and/or equipment damage and may void the warranty.</p>	

	<h2 style="margin: 0;">WARNING</h2>
<p>To reduce the risk of electrical shock, disconnect the power from the machine before removing the control box cover and before attempting any service procedures. Dangerous voltages are present in the electrical control box(es) and at the motor terminals. Only qualified personnel familiar with electrical test procedures, test equipment and safety precautions should attempt adjustments and troubleshooting.</p>	

	<h2 style="margin: 0;">WARNING</h2>
<p>Ensure that a ground wire from a proven earth ground is connected to the ground lug near the input power block on this machine. Without proper grounding, personal injury from electric shock and/or machine malfunctions could occur.</p>	

Electrical connections are made at the rear of the control module. The machine must be connected to the proper electrical supply shown on the identification plate attached to the side of the control module.

The AC drive requires a clean power supply, free from voltage spikes and surges. A voltage monitor should be used to check incoming power. Your local power company may provide such a monitor.

If input voltage measures above 230 Volts for a 200 Volt drive or above 440 Volts for a 400 Volt drive, ask the power company to lower the voltage. As an alternative, a step-down transformer kit is available from the distributor. Voltages above 250 Volts and 490 Volts require additional measures. Contact the distributor or the manufacturer for assistance.

**WARNING**

To reduce the risk of electrical shock, fire, explosion, serious injury or death:

- Disconnect electrical power to the washer-extractor before servicing it.
- Close the gas shut-off valve to the washer-extractor (when applicable) before servicing it.
- Never start the washer-extractor with any guards/panels removed.
- Whenever ground wires are removed during servicing, these ground wires must be reconnected to ensure that the washer-extractor is properly grounded.

W461R1

**WARNING**

To reduce the risk of electrical shock, never touch terminals or components of the AC drive unless the power is disconnected and the “CHARGE” indicator LED is off. The AC drive retains potentially deadly voltage for some time after the power is disconnected.

Tampering with the AC drive will void the warranty. There are no user-serviceable parts inside of the AC drive.

The washer-extractor should be connected to an individual branch circuit not shared with lighting or other equipment.

The connection should be shielded in a liquid-tight or approved flexible conduit with proper conductors of correct size installed in accordance with the National Electric Code or other applicable codes. The connection must be made by a qualified electrician using the wiring diagram provided with the washer-extractor or according to accepted European standards for equipment labeled with the CE mark.

For personal safety and for proper operation, the washer-extractor must be grounded in accordance with state and local codes. If such codes are not available, grounding must conform with the National Electric Code, article 250-95 or accepted European standards for equipment labeled with the CE mark. The ground connection must be made to a proven earth ground, not to conduit or water pipes.

If a delta supply system is used, the high leg may be connected to L3 on the UWPV models.

**DANGER**

To reduce the risk of serious injury, when using a parameter unit to control the AC drive, a large sign should be placed on the front of the machine warning people of the imminent danger. When controller the AC drive with a parameter unit, the machine's computer and its safety features are bypassed. This allows the basket to rotate at high speeds with the door open.

Mechanical & Electrical Design**Component Function****Keypad**

The keypad consists of pressure-sensitive switches enclosed within the control-module front decal. The keypad executes all commands and programming instructions to the computer.

Main Computer Board

The computer board is mounted on the inside front of the control module and supports the LED display and indicators. It also provides mounting and printed circuitry for the ROM, RAM, battery and beeper.

Fuse Board

The fuse board provides mounting for the output fuses, transformer and R.C. networks for the computer. It is mounted on a support bracket inside of the control module.

The AC drive provides thermal overload protection for the drive motor. However, a separate three-phase circuit breaker or electrical supply disconnecting device must be installed for complete electrical overload protection. This prevents damage to the motor by disconnecting all legs if one should be lost accidentally. Check the data plate on the back of the washer-extractor for circuit breaker requirements.

NOTE: Do NOT use fuses in place of a circuit breaker.

CAUTION

Do not use a phase adder on any variable-speed machine.



WARNING

To reduce the risk of electrical shock, fire, explosion, serious injury or death:

- **Disconnect electrical power to the washer-extractor before servicing it.**
- **Close the gas shut-off valve to the washer-extractor (when applicable) before servicing it.**
- **Never start the washer-extractor with any guards/panels removed.**
- **Whenever ground wires are removed during servicing, these ground wires must be reconnected to ensure that the washer-extractor is properly grounded.**

W461R1

Door

The door has an automatic door-locking mechanism which remains locked throughout the complete wash cycle.

Water Valves

Solenoid-operated valves control the washer-extractor's fill and operate the spray rinse. They are controlled by the computer. The valve configuration is shown below:

- UW35PV – Four 1/2 inch valves
- UW60PV – Two 3/4 inch, Two 1/2 inch valves
- UW80PV – Four 3/4 inch valves
- UW100PV – Four 3/4 inch valves
- UW125PV (Designs 1-6) – Four 3/4 inch valves
- UW125PV (Design 7) – Two 1 inch, Two 3/4 inch valves

Drain Valve

The UW35PV uses a motorized 2 inch ball valve, while the UW60, UW80, UW100 and UW125 use 3 inch ball valves.

Drain connection sizes are shown below:

	Number of drain valves	Drain connection per machine size
UW35PV	1	2 3/8 inch (60 mm)
UW60PV	1	3 inch (76 mm)
UW80PV	2	3 inch (76 mm)
UW100PV	2	3 inch (76 mm)
UW125PV	2	3 inch (76 mm)

Control Module

All electrical controls (e.g., computer board, buzzer, water level switches and the door lock switch) are located in a stainless steel enclosure mounted on top of the shell. It is provided with conduit connections for safe and reliable connection to the drive motor. The electrical power source is connected to the power input terminal strip inside the back of the control module.

AC Drive Control

The AC drive control module provides seven programmable motor speeds from a single motor. It lowers inrush current and controls the rate of acceleration and deceleration. A parameter unit is available as a troubleshooting aid and to program changes in the drive control. The AC drive is located inside of the control module.

CAUTION

Never change the AC drive's preset parameters without consulting the factory. Permanent damage could result to the AC drive and/or to the drive motor.

AC Drive Interface Board

The AC drive interface board converts motor logic from the WE-6 computer to the correct signals for the AC drive. All logic inputs to the computer are routed through this board.

Door Box

The door box contains the door lock microswitch, interlock magnetic switch and the door unlock solenoid.

Section 4

Troubleshooting



WARNING

To reduce the risk of electrical shock, fire, explosion, serious injury or death:

- Disconnect electrical power to the washer-extractor before servicing it.
- Close the gas shut-off valve to the washer-extractor (when applicable) before servicing it.
- Never start the washer-extractor with any guards/panels removed.
- Whenever ground wires are removed during servicing, these ground wires must be reconnected to ensure that the washer-extractor is properly grounded.

W461R1

Section 4 Troubleshooting

1. WE-6 CONTROL HAS NO VISIBLE DISPLAY — P AND N-VOLTAGE MODELS

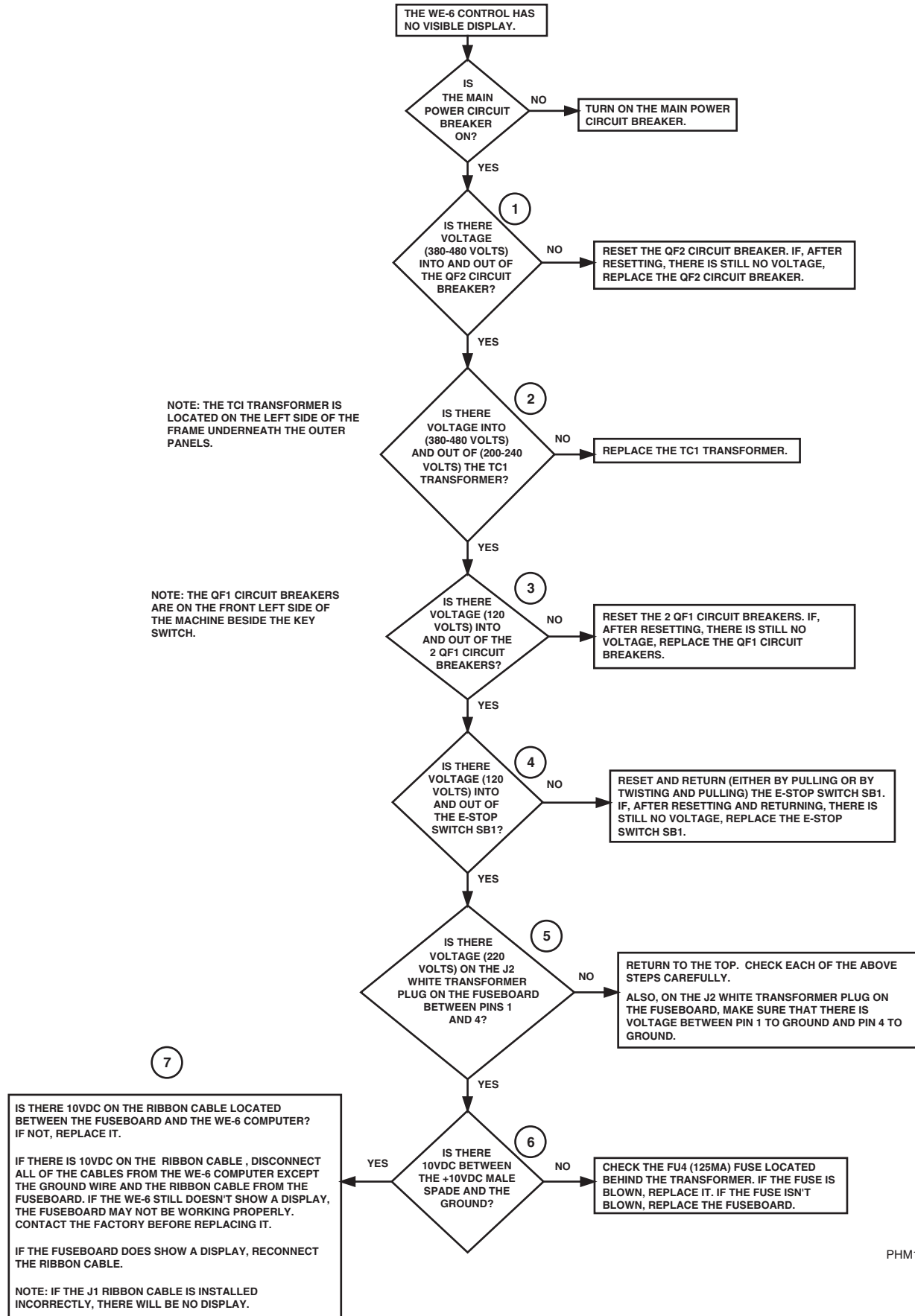

PHM1924S

Please refer to the following 2 pages for wiring diagram information.

Section 4 Troubleshooting

WE-6 Control Has No Visible Display — P and N-Voltage Models (Sheet 1 of 2)

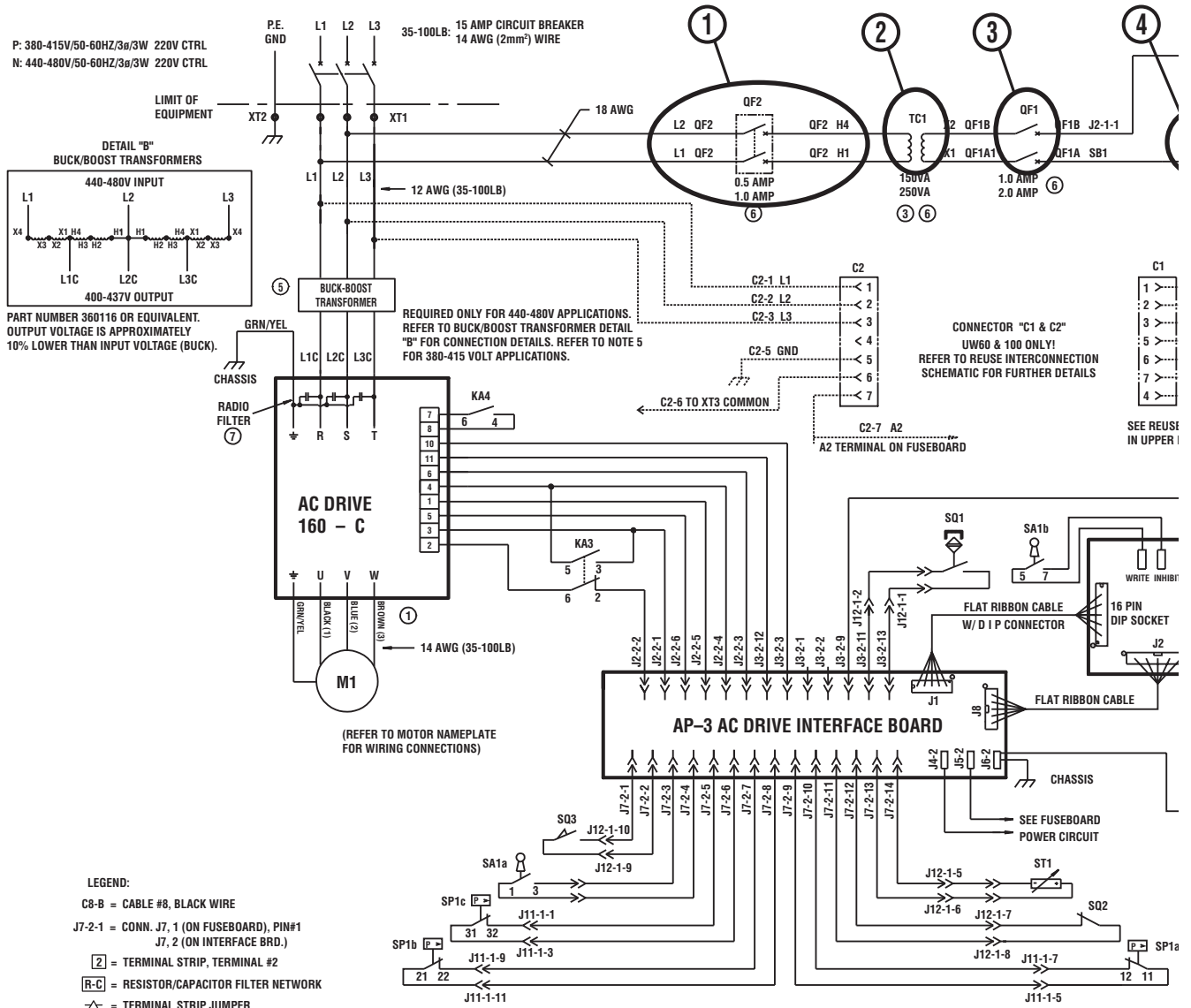

- NOTES:**
- 1 THE DRIVE MOTOR (M1) IS DUAL VOLTAGE CAPABLE. REFER TO NAMEPLATE OF MOTOR BEFORE WIRING. IF MOTOR ROTATION IS INCORRECT, SWAP ANY 2 WIRES OF CABLE BETWEEN AC DRIVE AND MOTOR.
 - 2 REFER TO PROGRAMMING MANUAL FOR DETAILED INSTRUCTIONS TO OPERATE SUPPLIES. SUPPLY 5 OUTPUT PROVIDES POWER TO SWITCH RELAYS KA1 & KA2 IN ORDER TO ENABLE EXTERNAL SUPPLIES 6 THROUGH 9. EXAMPLE: IF SUPPLY 1 IS PROGRAMMED, THE SUPPLY 1 OUTPUT PROVIDES A 220V SIGNAL TO EXTERNAL SUPPLY 1. WHEN SUPPLY 5 IS PROGRAMMED WITH SUPPLY 1, THE SUPPLY 1 OUTPUT THEN PROVIDES A 220V SIGNAL TO EXTERNAL SUPPLY 6.
 - 3 REFER TO DWG. #635635 FOR CONNECTION DETAILS OF CONTROL TRANSFORMER.
 - 4 AIR OPERATED DRAIN SYSTEM AVAILABLE AS AN OPTION
 - 5 380-415V APPLICATIONS DO NOT REQUIRE BUCK-BOOST TRANSFORMERS. WIRES L1, L2 & L3 WILL CONNECT DIRECTLY TO AC DRIVE FROM INPUT POWER DISTRIBUTION TERMINAL XT1. FOR 440-480V APPLICATIONS, REFER TO BUCK-BOOST TRANSFORMER SCHEMATIC FOR CONNECTION DETAILS.
 - 6 UW80-100 MACHINES WITH DUAL ELECTRICALLY OPERATED DRAIN VALVES REQUIRE A 250VA CONTROL TRANSFORMER (TC1), TWO AMP 250VA CONTROL CIRCUIT BREAKERS (QF1) AND A 1.0 AMP TRANSFORMER PRIMARY (QF2) CIRCUIT BREAKER. ALL MACHINES WITH SINGLE ELECTRICALLY OPERATED DRAIN VALVE REQUIRE A 150VA XFMR, TWO 1 AMP CONTROL CIRCUIT BREAKERS (QF1) AND A 0.5 AMP TRANSFORMER PRIMARY CIRCUIT BREAKER (QF2). ALL AIR-OP DRAIN SYSTEMS REQUIRE 150VA XFMR.
 - 7 AN ADDITIONAL FILTER (P/N 635654) IS REQUIRED ACROSS THE INPUT OF THE AC DRIVE.

WE-6 Control Has No Visible Display — P and N-Voltage Models (Sheet 2 of 2)

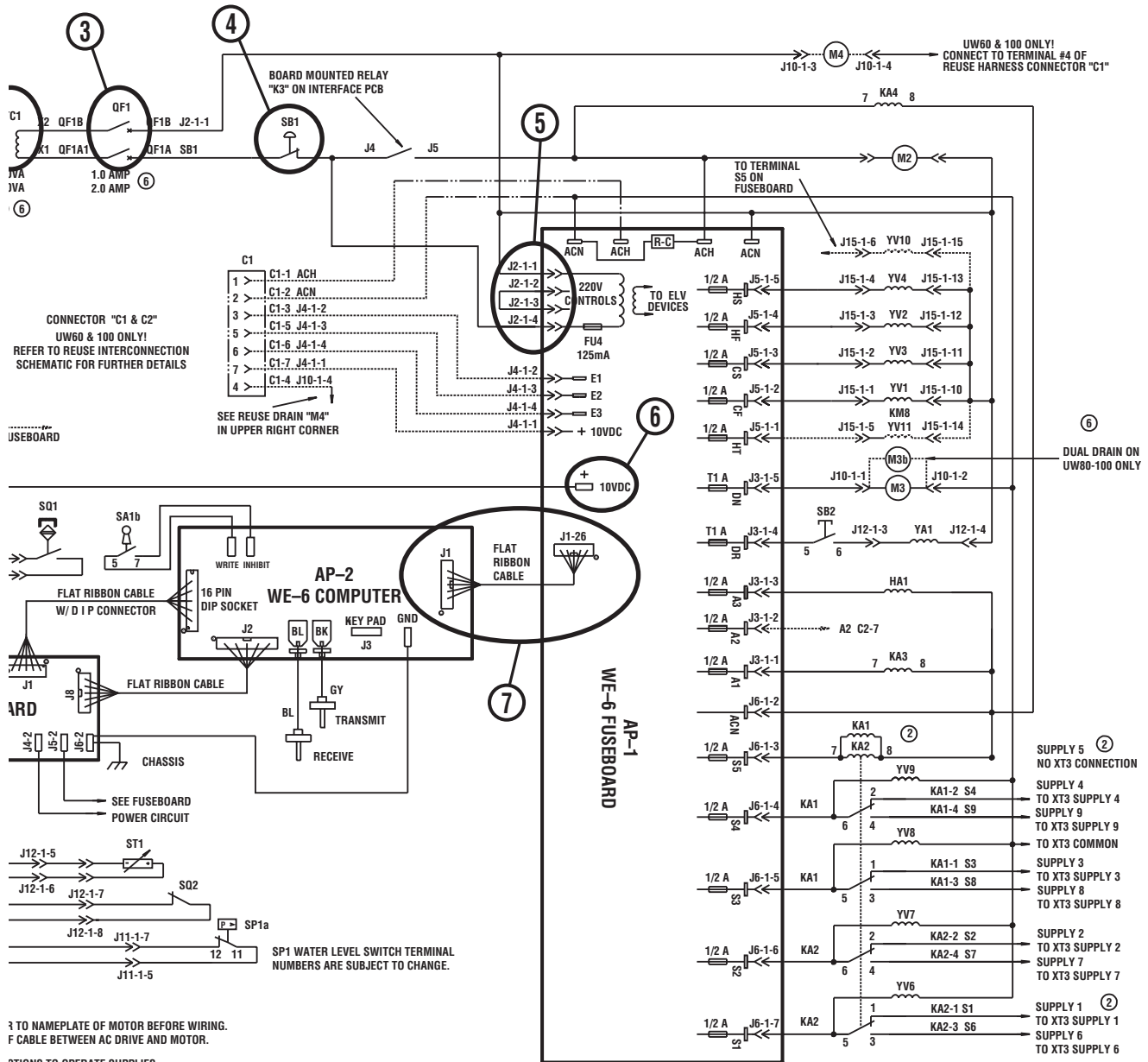

3 TO NAMEPLATE OF MOTOR BEFORE WIRING.
 F CABLE BETWEEN AC DRIVE AND MOTOR.

CTIONS TO OPERATE SUPPLIES.
 CA1 & KA2 IN ORDER TO ENABLE EXTERNAL
 AMMED, THE SUPPLY 1 OUTPUT PROVIDES A
 PROGRAMMED WITH SUPPLY 1, THE SUPPLY 1
 PLY 6.

NTROL TRANSFORMER.

TRANSFORMERS. WIRES L1, L2 & L3 WILL CONNECT
 N TERMINAL XT1.
 NSFORMER SCHEMATIC FOR CONNECTION DETAILS.

D DRAIN VALVES REQUIRE A 250VA CONTROL
 BREAKERS (QF1) AND A 1.0 AMP TRANSFORMER

AIN VALVE REQUIRE A 150VA XFMR, TWO 1 AMP
 FORMER PRIMARY CIRCUIT BREAKER (QF2).

: THE INPUT OF THE AC DRIVE.

PHM1925S

Section 4 Troubleshooting

2. WE-6 CONTROL HAS NO VISIBLE DISPLAY — Q-VOLTAGE MODEL

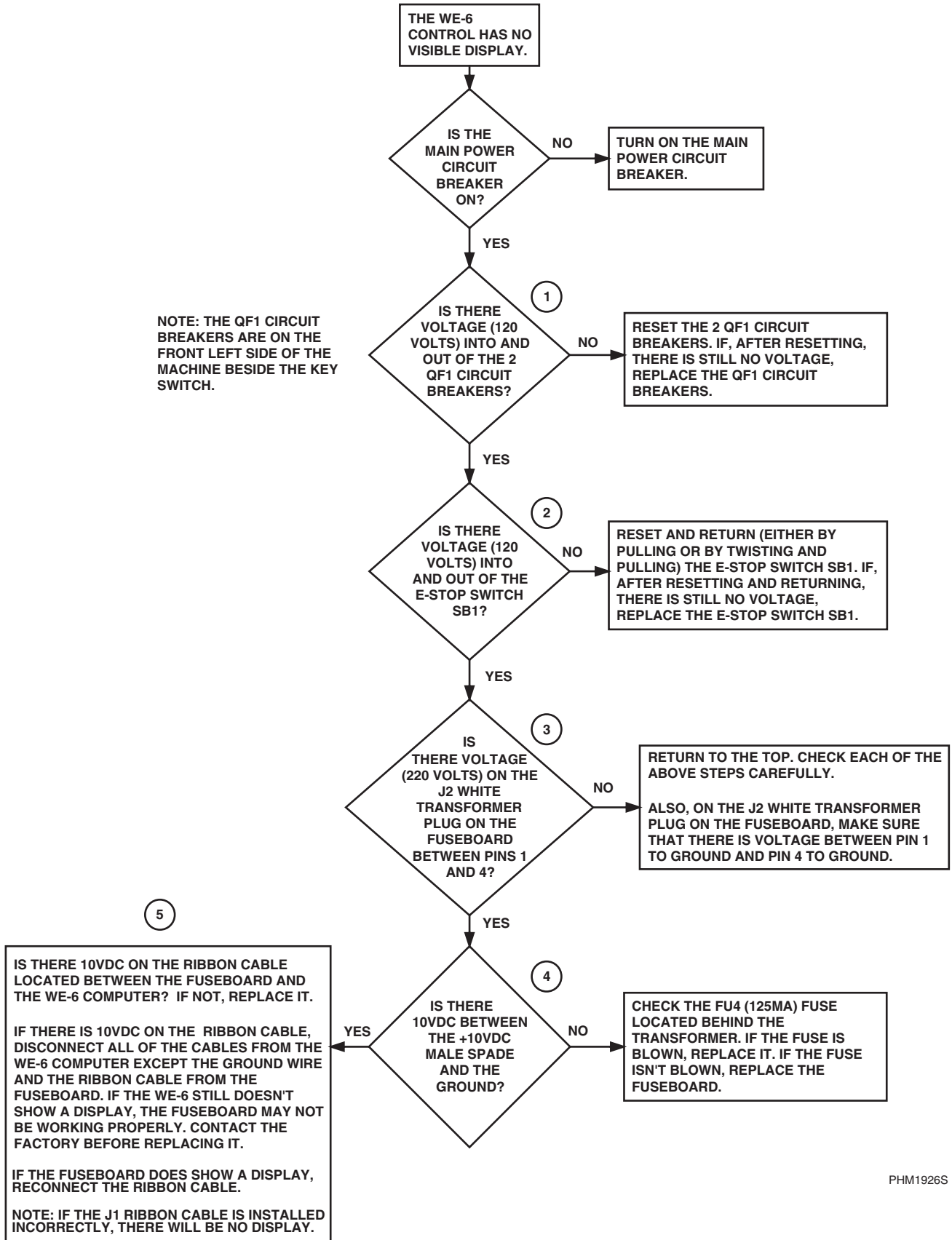

PHM1926S

Please refer to the following 2 pages for wiring diagram information.

Section 4 Troubleshooting

WE-6 Control Has No Visible Display — Q-Voltage Models (Sheet 1 of 2)

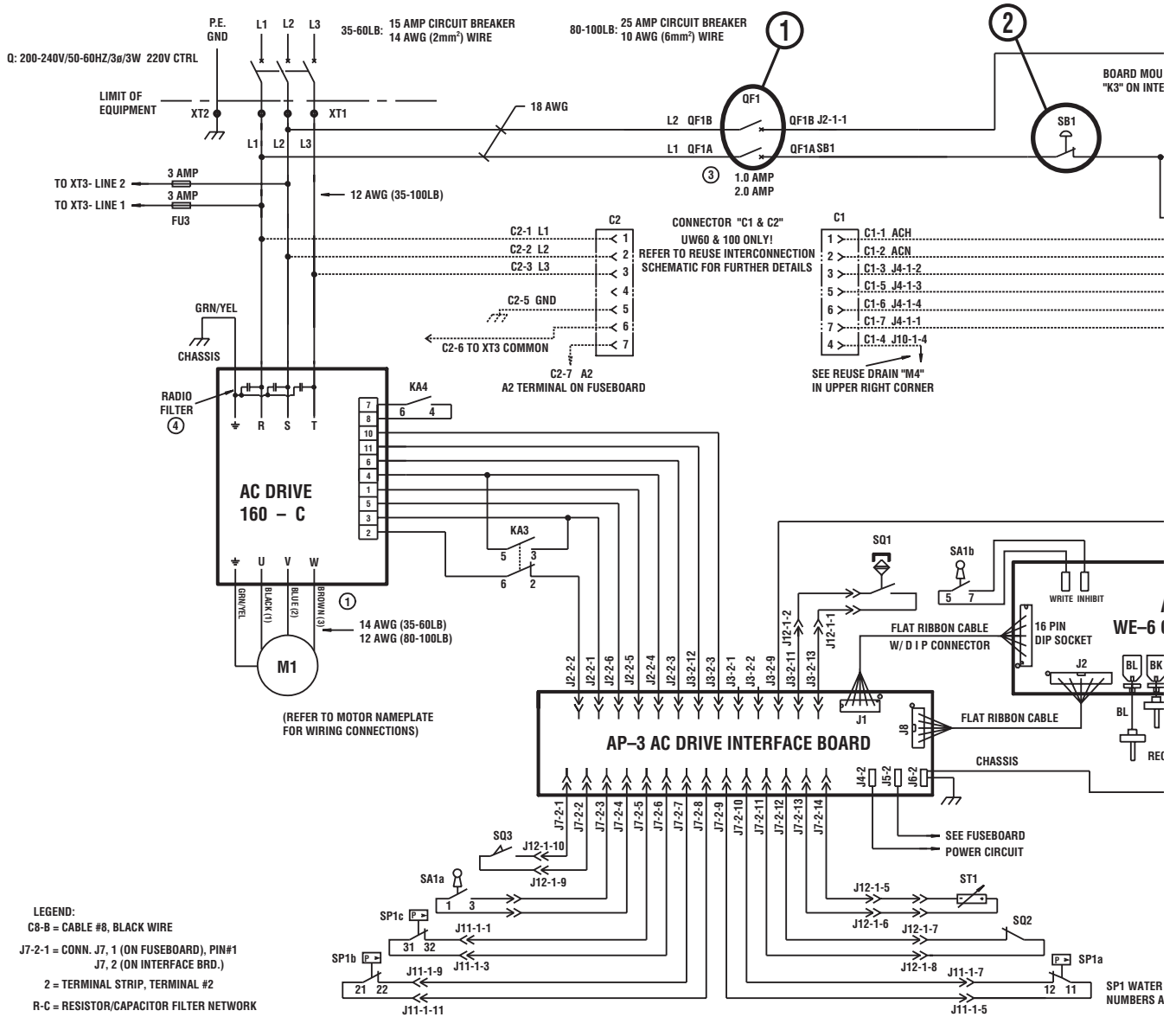

LEGEND:
 C8-B = CABLE #8, BLACK WIRE
 J7-2-1 = CONN. J7, 1 (ON FUSEBOARD), PIN#1
 J7, 2 (ON INTERFACE BRD.)
 2 = TERMINAL STRIP, TERMINAL #2
 R-C = RESISTOR/CAPACITOR FILTER NETWORK
 Δ = TERMINAL STRIP JUMPER
 (TERMINAL STRIP JUMPERS MAY BE USED IN VARIOUS PLACES NOT SHOWN ON SCHEMATIC)

TYPICAL RELAY

—	—	—	—

ODD NUMBERED CONTACTS ARE ISOLATED FROM EVEN NUMBERED CONTACTS BUT OPERATE SIMULTANEOUSLY. TERMINAL NUMBERS MAY VARY FROM RELAY TO RELAY BUT TERMINAL POSITIONS ARE THE SAME.

- NOTES:**
- 1 THE DRIVE MOTOR (M1) IS DUAL VOLTAGE CAPABLE. REFER TO NAMEPLATE OF MOTOR BEFORE WIRING. IF MOTOR ROTATION IS INCORRECT, SWAP ANY 2 WIRES OF CABLE BETWEEN AC DRIVE AND MOTOR.
 - 2 REFER TO PROGRAMMING MANUAL FOR DETAILED INSTRUCTIONS TO OPERATE SUPPLIES. SUPPLY 5 OUTPUT PROVIDES POWER TO ACTIVATE RELAYS KA1 & KA2 IN ORDER TO ENABLE EXTERNAL SUPPLIES 6 THROUGH 9. EXAMPLE: IF SUPPLY 1 IS PROGRAMMED, THE SUPPLY 1 OUTPUT PROVIDES A 220V SIGNAL TO EXTERNAL SUPPLY 1. WHEN SUPPLY 5 IS PROGRAMMED WITH SUPPLY 1, THE SUPPLY 1 OUTPUT THEN PROVIDES A 220V SIGNAL TO EXTERNAL SUPPLY 6.
 - 3 UW80-100 MACHINES WITH DUAL ELECTRICALLY OPERATED DRAIN VALVES REQUIRE TWO 2 AMP, 250V CONTROL CIRCUIT BREAKERS (QF1). LIKewise FOR REUSE DRAIN M4. ALL MACHINES WITH SINGLE ELECTRIC DRAIN VALVES REQUIRE TWO 1 AMP, 250V CONTROL CIRCUIT BREAKERS (QF1).
 - 4 AN ADDITIONAL FILTER (P/N 635654) IS REQUIRED ACROSS THE INPUT OF THE AC DRIVE.

WE-6 Control Has No Visible Display — Q-Voltage Models (Sheet 2 of 2)

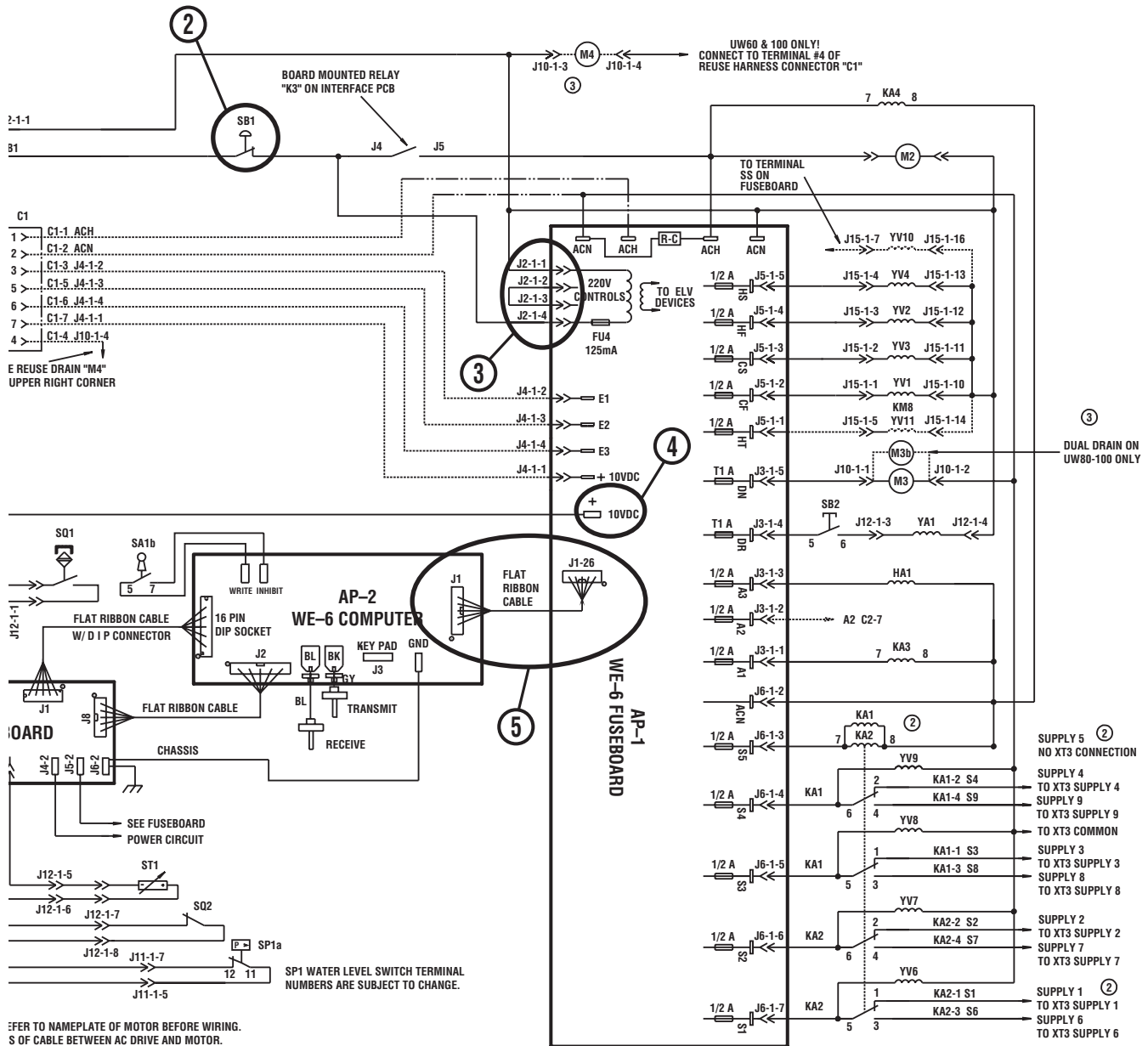

REFER TO NAMEPLATE OF MOTOR BEFORE WIRING.
 5' OF CABLE BETWEEN AC DRIVE AND MOTOR.
 INSTRUCTIONS TO OPERATE SUPPLIES.
 ALWAYS KA1 & KA2 IN ORDER TO ENABLE EXTERNAL PROGRAMMED, THE SUPPLY 1 OUTPUT PROVIDES A COMMON IS PROGRAMMED WITH SUPPLY 1, THE SUPPLY 1 SUPPLY 6.
 DUAL DRAIN VALVES REQUIRE TWO 2 AMP, 250V FUSE DRAIN M4.
 REQUIRE TWO 1 AMP, 250V

EXTERNAL SUPPLY TERMINAL STRIP (XT3) LOCATED ON REAR OF MODULE.
 EXTERNAL SUPPLY 5 INTENTIONALLY OMITTED. SUPPLY 5 ENERGIZES RELAYS KA1 & KA2 TO ENABLE SUPPLIES 6 THRU 9.
 THIS COMMON IS NOT A TRUE NEUTRAL.
 DO NOT CONNECT LOAD BETWEEN LINE 1, LINE 2 OR LINE 3 AND THIS COMMON.
 220V BETWEEN ALL LINES AND COMMON.

VERIFY THE INPUT OF THE AC DRIVE.

PHM1927S

Section 4 Troubleshooting

3. NO FILL ANALYSIS

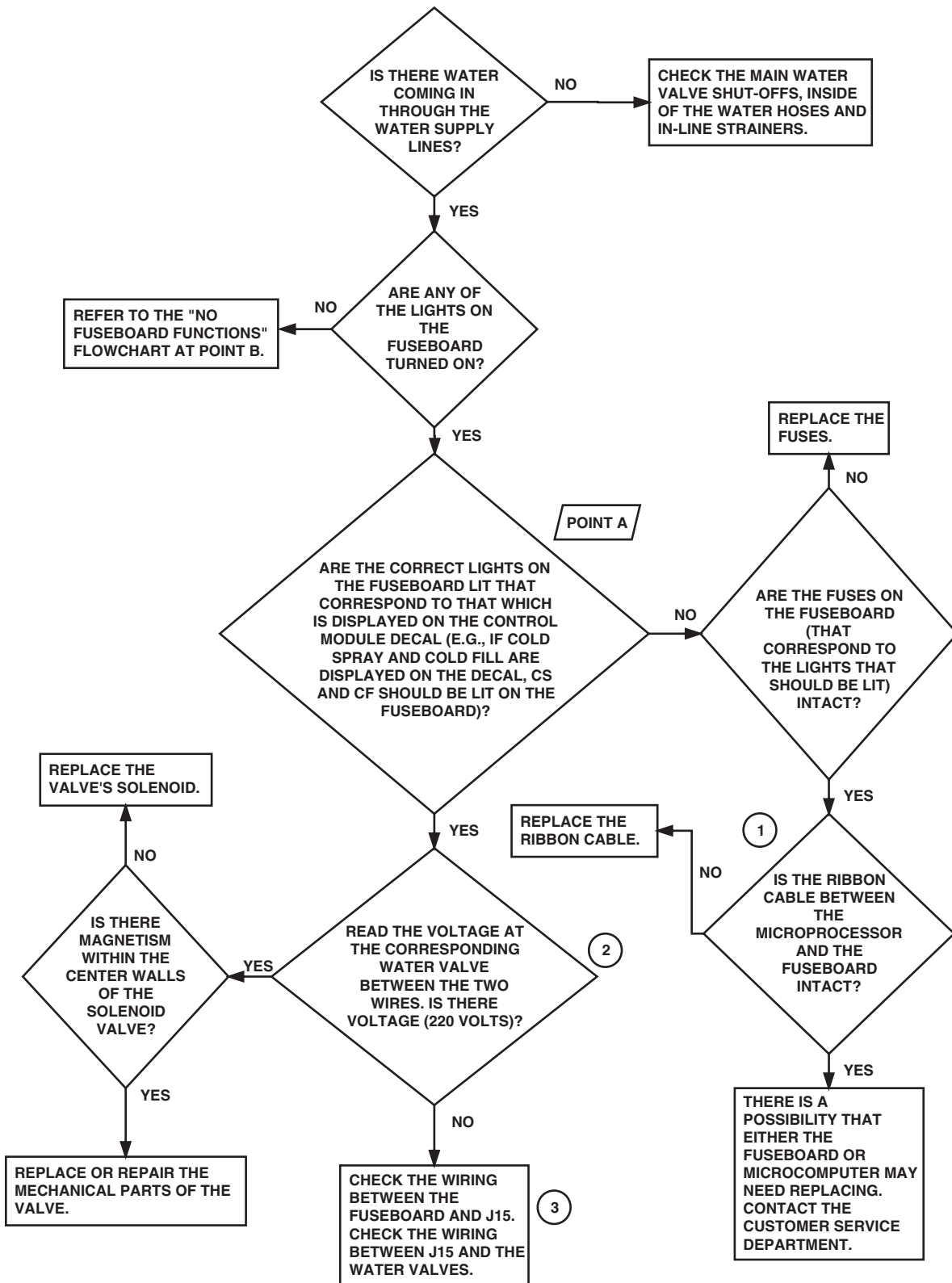

PHM1922S

Please refer to the following 2 pages for wiring diagram information.

No Fill Analysis (Sheet 1 of 2)

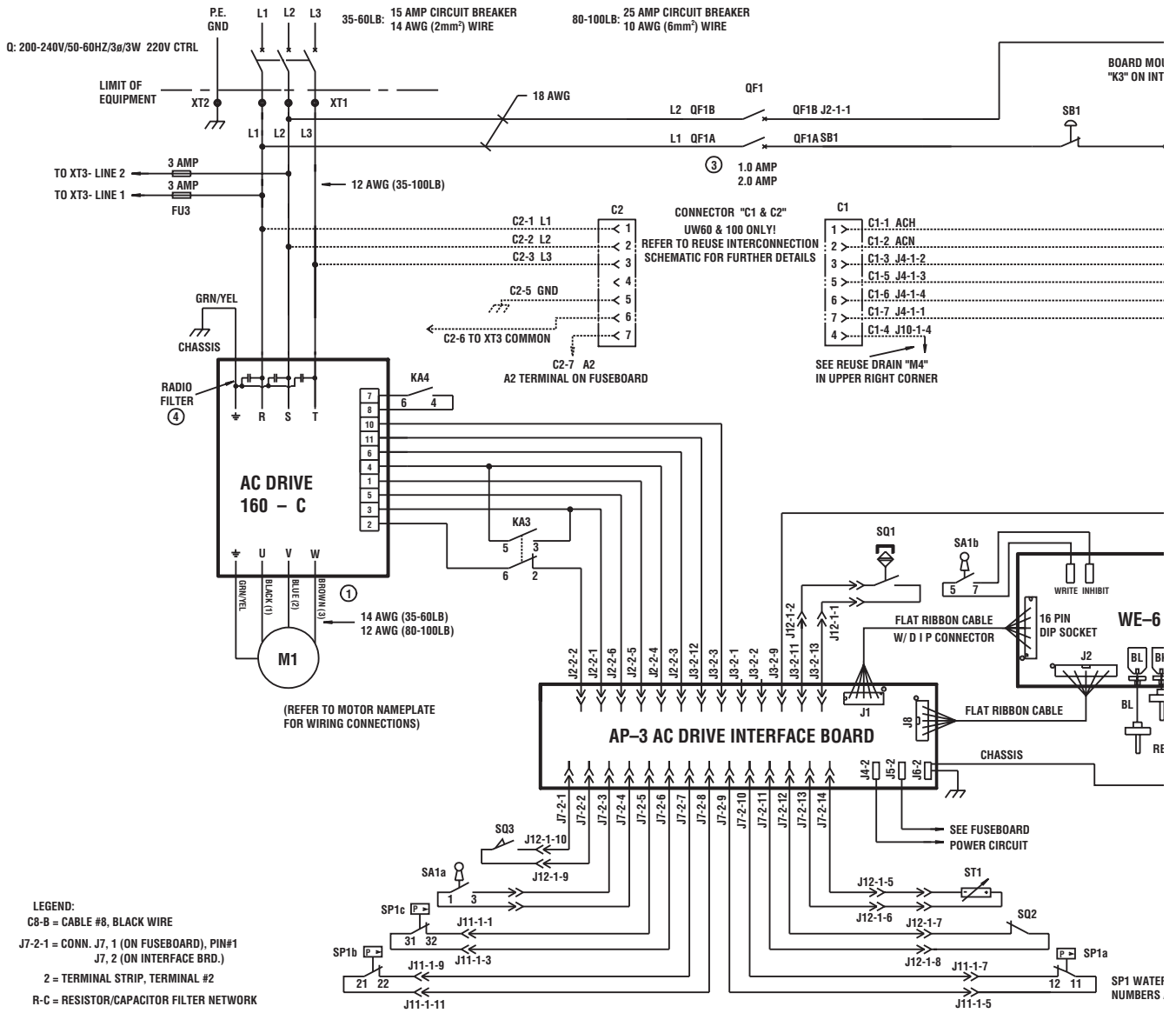

- NOTES:**
- 1 THE DRIVE MOTOR (M1) IS DUAL VOLTAGE CAPABLE. REFER TO NAMEPLATE OF MOTOR BEFORE WIRING. IF MOTOR ROTATION IS INCORRECT, SWAP ANY 2 WIRES OF CABLE BETWEEN AC DRIVE AND MOTOR.
 - 2 REFER TO PROGRAMMING MANUAL FOR DETAILED INSTRUCTIONS TO OPERATE SUPPLIES. SUPPLY 5 OUTPUT PROVIDES POWER TO ACTIVATE RELAYS KA1 & KA2 IN ORDER TO ENABLE EXTERNAL SUPPLIES 6 THROUGH 9. EXAMPLE: IF SUPPLY 1 IS PROGRAMMED, THE SUPPLY 1 OUTPUT PROVIDES A 220V SIGNAL TO EXTERNAL SUPPLY 1. WHEN SUPPLY 5 IS PROGRAMMED WITH SUPPLY 1, THE SUPPLY 1 OUTPUT THEN PROVIDES A 220V SIGNAL TO EXTERNAL SUPPLY 6.
 - 3 UW80-100 MACHINES WITH DUAL ELECTRICALLY OPERATED DRAIN VALVES REQUIRE TWO 2 AMP, 250V CONTROL CIRCUIT BREAKERS (QF1). LIKEWISE FOR REUSE DRAIN M4. ALL MACHINES WITH SINGLE ELECTRIC DRAIN VALVES REQUIRE TWO 1 AMP, 250V CONTROL CIRCUIT BREAKERS (QF1).
 - 4 AN ADDITIONAL FILTER (P/N 635654) IS REQUIRED ACROSS THE INPUT OF THE AC DRIVE.

No Fill Analysis (Sheet 2 of 2)

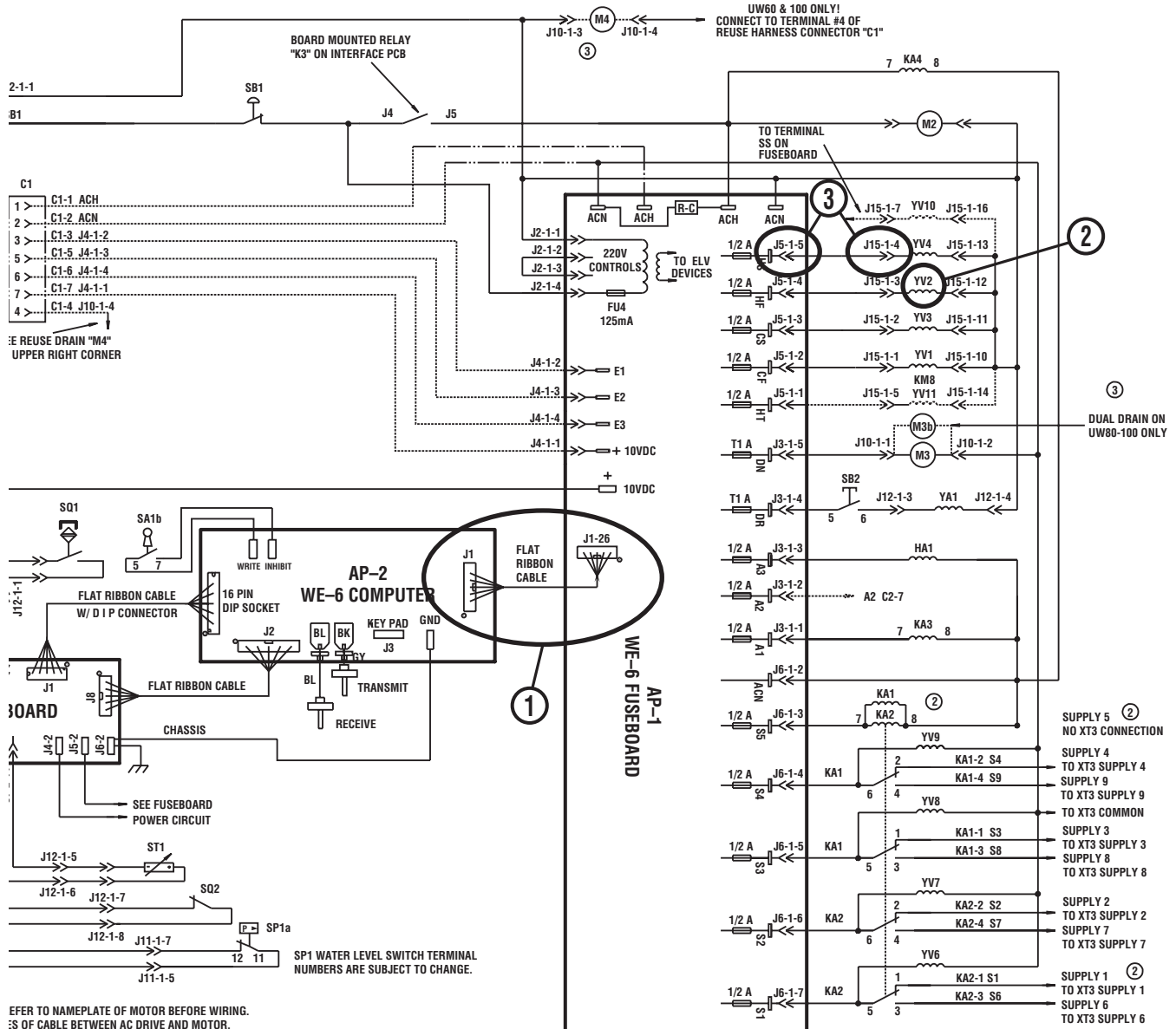

REFER TO NAMEPLATE OF MOTOR BEFORE WIRING. DISCONNECT SUPPLY CABLE BETWEEN AC DRIVE AND MOTOR.

INSTRUCTIONS TO OPERATE SUPPLIES.
 ALWAYS KEYS KA1 & KA2 IN ORDER TO ENABLE EXTERNAL PROGRAMMED, THE SUPPLY 1 OUTPUT PROVIDES A COMMON LINE. IF SUPPLY 1 IS PROGRAMMED WITH SUPPLY 1, THE SUPPLY 1 OUTPUT PROVIDES SUPPLY 6.

VALVED DRAIN VALVES REQUIRE TWO 2 AMP, 250V SUPPLIES. USE DRAIN M4. SUPPLIES REQUIRE TWO 1 AMP, 250V SUPPLIES.

EXTERNAL SUPPLY TERMINAL STRIP (XT3) LOCATED ON REAR OF MODULE. EXTERNAL SUPPLY 5 INTENTIONALLY OMITTED. SUPPLY 5 ENERGIZES RELAYS KA1 & KA2 TO ENABLE SUPPLIES 6 THRU 9. THIS COMMON IS NOT A TRUE NEUTRAL. DO NOT CONNECT LOAD BETWEEN LINE 1, LINE 2 OR LINE 3 AND THIS COMMON. 220V BETWEEN ALL LINES AND COMMON.

DISCONNECT THE INPUT OF THE AC DRIVE.

PHM1923S

Section 4 Troubleshooting

**4. WATER RUNS CONTINUOUSLY INTO THE WASHER-EXTRACTOR
(Either when the machine is in cycle or not)**

Note: This information applies to the four main fill valves as well as the 4-way supply valves. The first task in this process is to determine which valve is staying on. If it is one of the four main valves (i.e., hot spray, hot fill, cold spray or cold fill), this may be done by individually shutting off the water supply to each valve. If it is a supply valve that is staying open, find the location in the dry supply box where the water is flushing into and follow the hose back to the solenoid. Once the valve has been identified, proceed as follows:

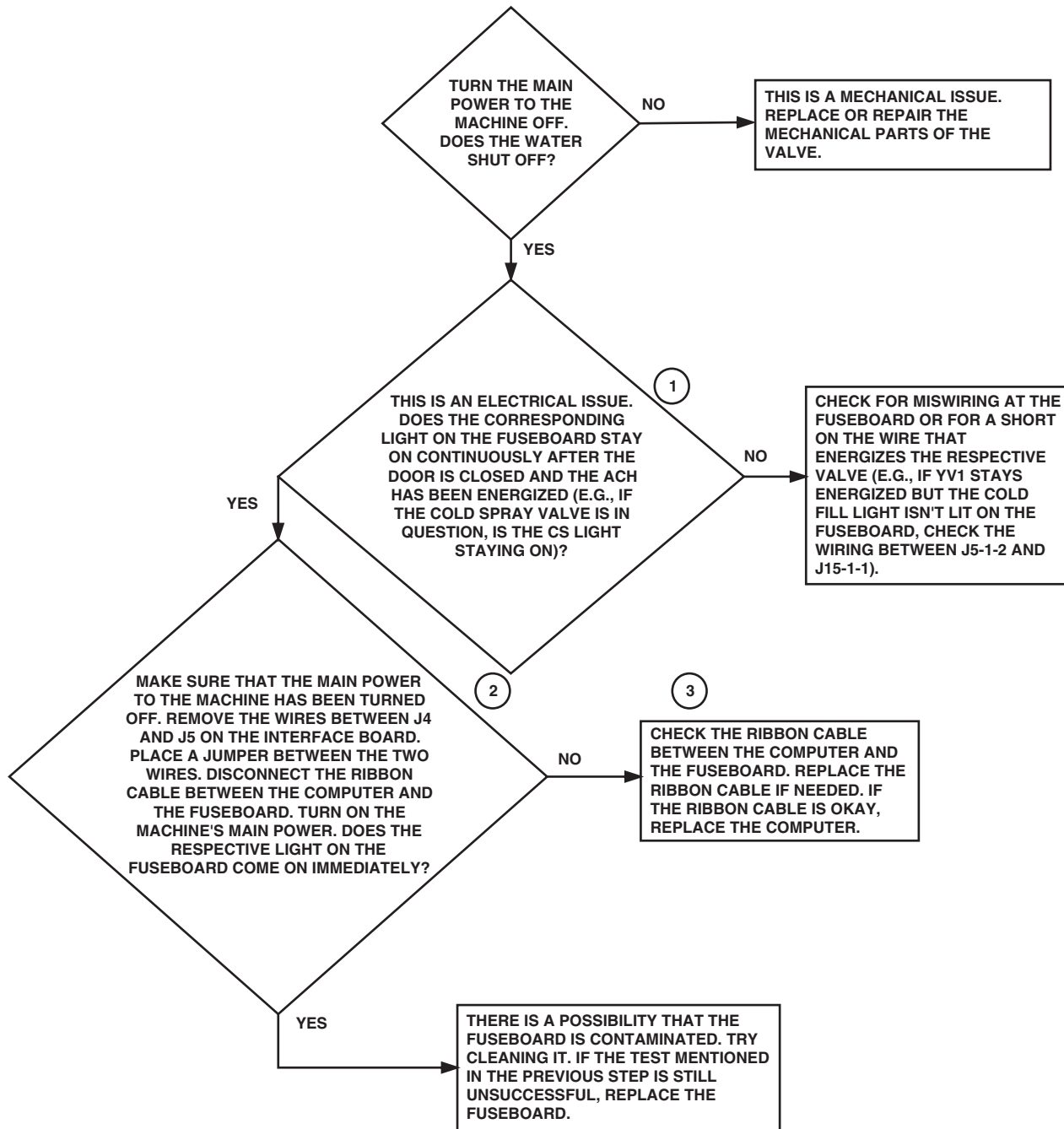

PHM1920S

Please refer to the following 2 pages for wiring diagram information.

Section 4 Troubleshooting

Water Runs Continuously into the Washer-Extractor
(Either when the machine is in cycle or not) (Sheet 1 of 2)

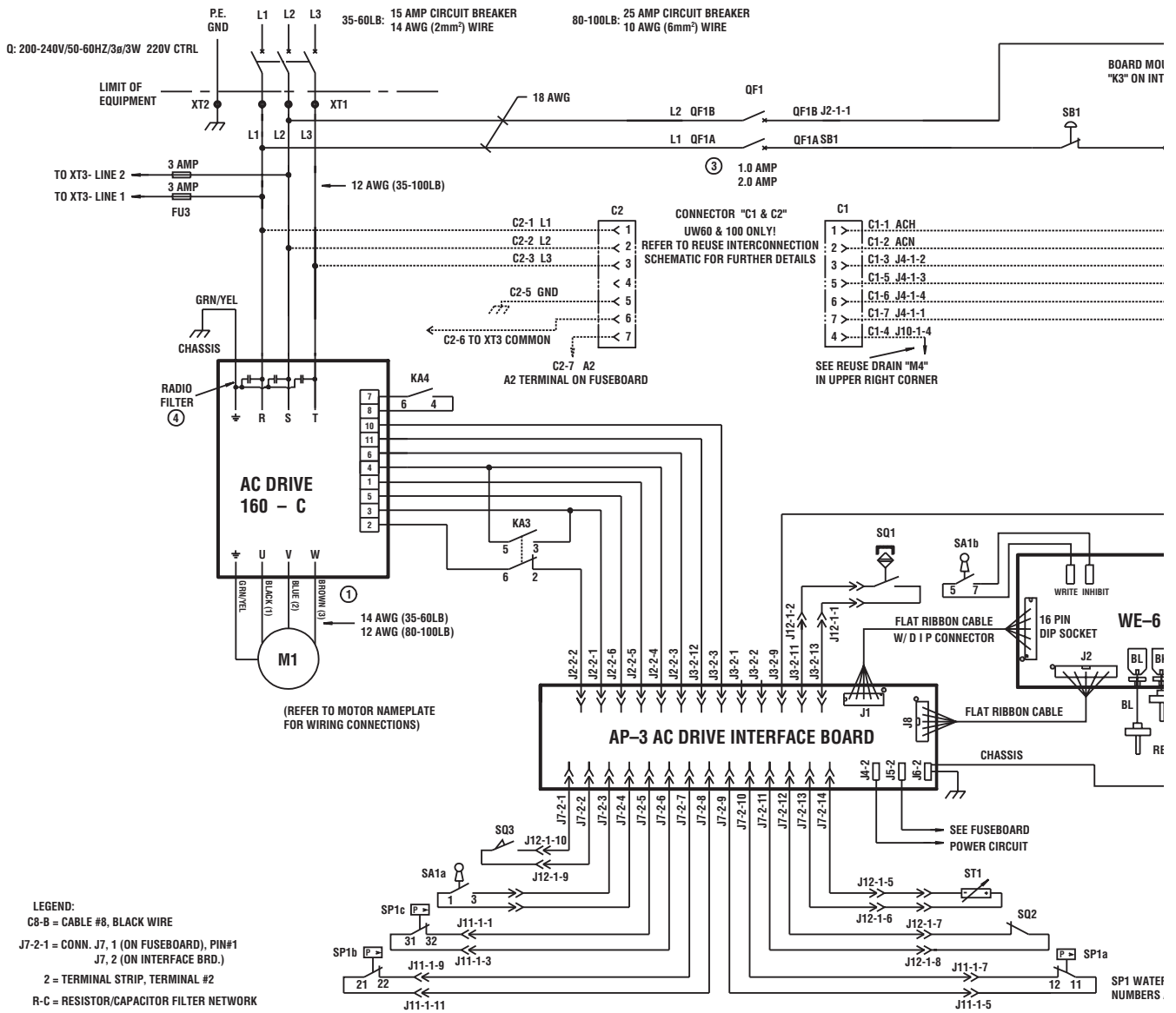

LEGEND:
 C8-B = CABLE #8, BLACK WIRE
 J7-2-1 = CONN. J7, 1 (ON FUSEBOARD), PIN#1
 J7, 2 (ON INTERFACE BRD.)
 2 = TERMINAL STRIP, TERMINAL #2
 R-C = RESISTOR/CAPACITOR FILTER NETWORK
 △ = TERMINAL STRIP JUMPER
 (TERMINAL STRIP JUMPERS MAY BE USED IN VARIOUS PLACES NOT SHOWN ON SCHEMATIC)

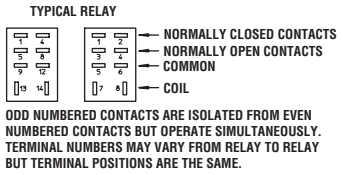

- NOTES:
- 1 THE DRIVE MOTOR (M1) IS DUAL VOLTAGE CAPABLE. REFER TO NAMEPLATE OF MOTOR BEFORE WIRING. IF MOTOR ROTATION IS INCORRECT, SWAP ANY 2 WIRES OF CABLE BETWEEN AC DRIVE AND MOTOR.
 - 2 REFER TO PROGRAMMING MANUAL FOR DETAILED INSTRUCTIONS TO OPERATE SUPPLIES. SUPPLY 5 OUTPUT PROVIDES POWER TO ACTIVATE RELAYS KA1 & KA2 IN ORDER TO ENABLE EXTERNAL SUPPLIES 6 THROUGH 9. EXAMPLE: IF SUPPLY 1 IS PROGRAMMED, THE SUPPLY 1 OUTPUT PROVIDES A 220V SIGNAL TO EXTERNAL SUPPLY 1. WHEN SUPPLY 5 IS PROGRAMMED WITH SUPPLY 1, THE SUPPLY 1 OUTPUT THEN PROVIDES A 220V SIGNAL TO EXTERNAL SUPPLY 6.
 - 3 UW80-100 MACHINES WITH DUAL ELECTRICALLY OPERATED DRAIN VALVES REQUIRE TWO 2 AMP, 250V CONTROL CIRCUIT BREAKERS (QF1). LIKEWISE FOR REUSE DRAIN M4. ALL MACHINES WITH SINGLE ELECTRIC DRAIN VALVES REQUIRE TWO 1 AMP, 250V CONTROL CIRCUIT BREAKERS (QF1).
 - 4 AN ADDITIONAL FILTER (P/N 635654) IS REQUIRED ACROSS THE INPUT OF THE AC DRIVE.

Water Runs Continuously into the Washer-Extractor (Either when the machine is in cycle or not) (Sheet 2 of 2)

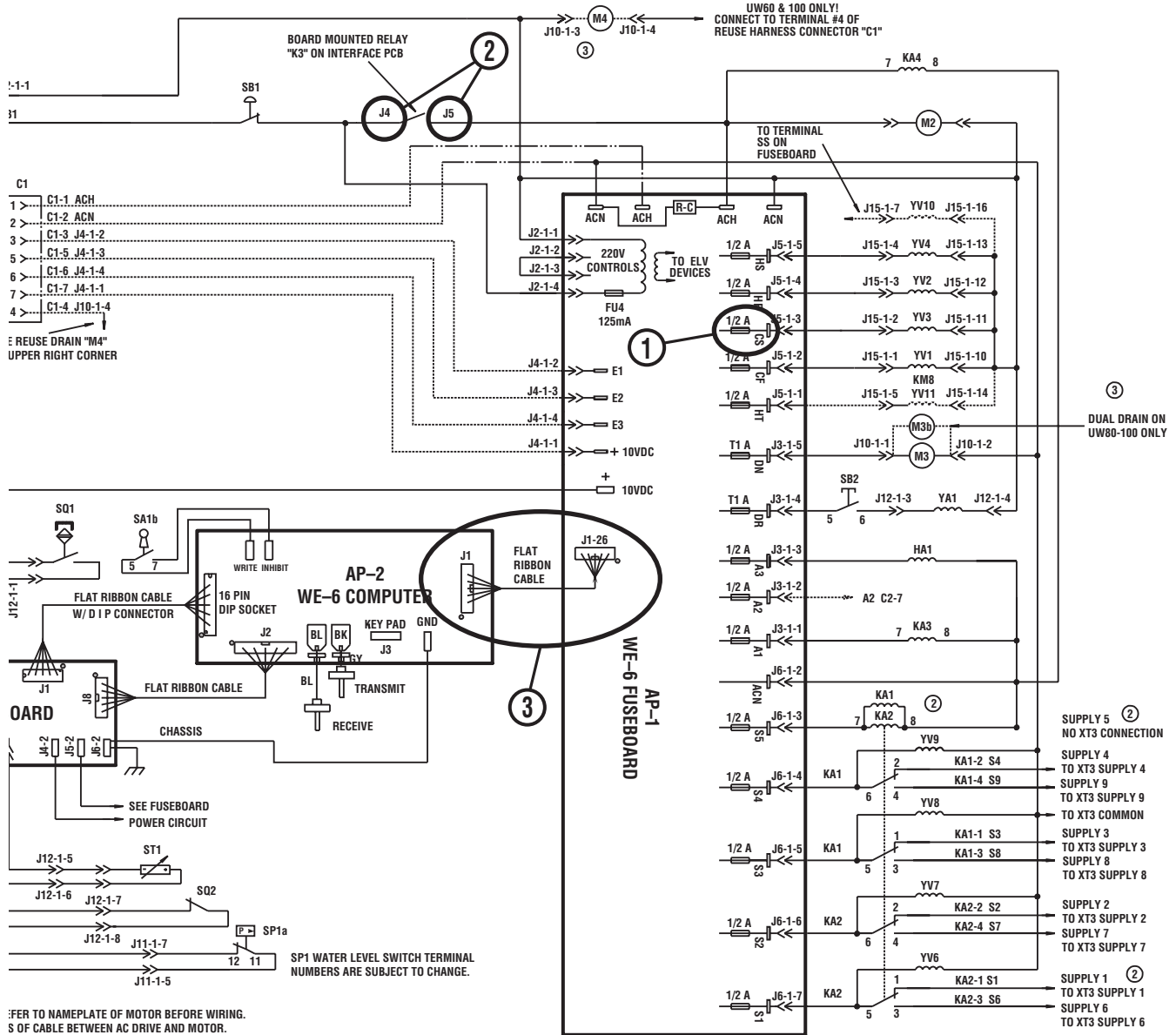

REFER TO NAMEPLATE OF MOTOR BEFORE WIRING.
CHECK POLARITY OF CABLE BETWEEN AC DRIVE AND MOTOR.

INSTRUCTIONS TO OPERATE SUPPLIES.
CHECK SUPPLIES KA1 & KA2 IN ORDER TO ENABLE EXTERNAL PROGRAMMING. THE SUPPLY 1 OUTPUT PROVIDES A COMMON NEUTRAL. THIS COMMON IS NOT A TRUE NEUTRAL. DO NOT CONNECT LOAD BETWEEN LINE 1, LINE 2 OR LINE 3 AND THIS COMMON.
220V BETWEEN ALL LINES AND COMMON.

EXTERNAL DRAIN VALVES REQUIRE TWO TWO AMP, 250V CIRCUIT BREAKERS.
INTERNAL DRAIN M4, REQUIRE TWO TWO AMP, 250V CIRCUIT BREAKERS.

VERIFY THE INPUT OF THE AC DRIVE.

EXTERNAL SUPPLY TERMINAL STRIP (XT3) LOCATED ON REAR OF MODULE.
EXTERNAL SUPPLY 5 INTENTIONALLY OMITTED. SUPPLY 5 ENERGIZES RELAYS KA1 & KA2 TO ENABLE SUPPLIES 6 THRU 9.
THIS COMMON IS NOT A TRUE NEUTRAL.
DO NOT CONNECT LOAD BETWEEN LINE 1, LINE 2 OR LINE 3 AND THIS COMMON.
220V BETWEEN ALL LINES AND COMMON.

PHM1921S

Section 4 Troubleshooting

5. DOOR LOCK SWITCH ANALYSIS

Symptom: The WE-6 Display Reads “Close Door”

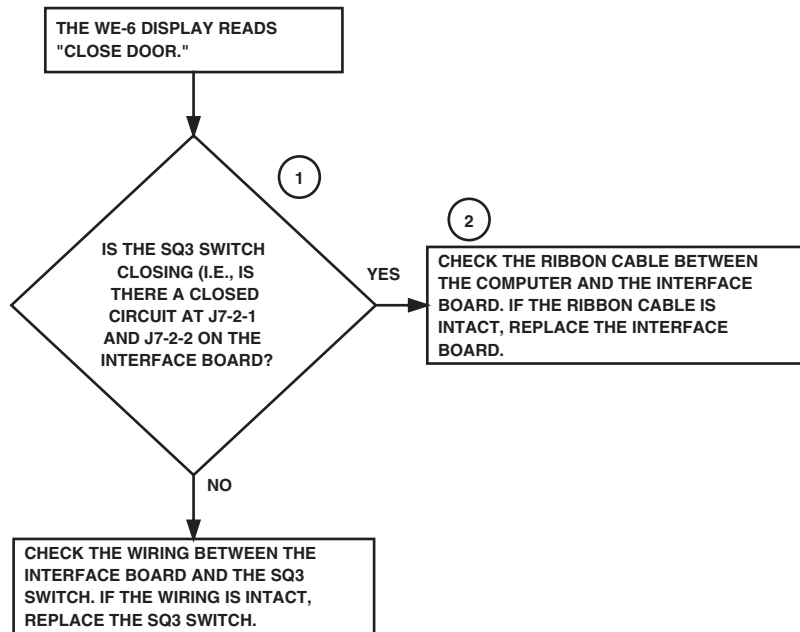

PHM1918S

Please refer to the following 2 pages for wiring diagram information.

Door Lock Switch Analysis The WE-6 Display Reads "Close Door" (Sheet 1 of 2)

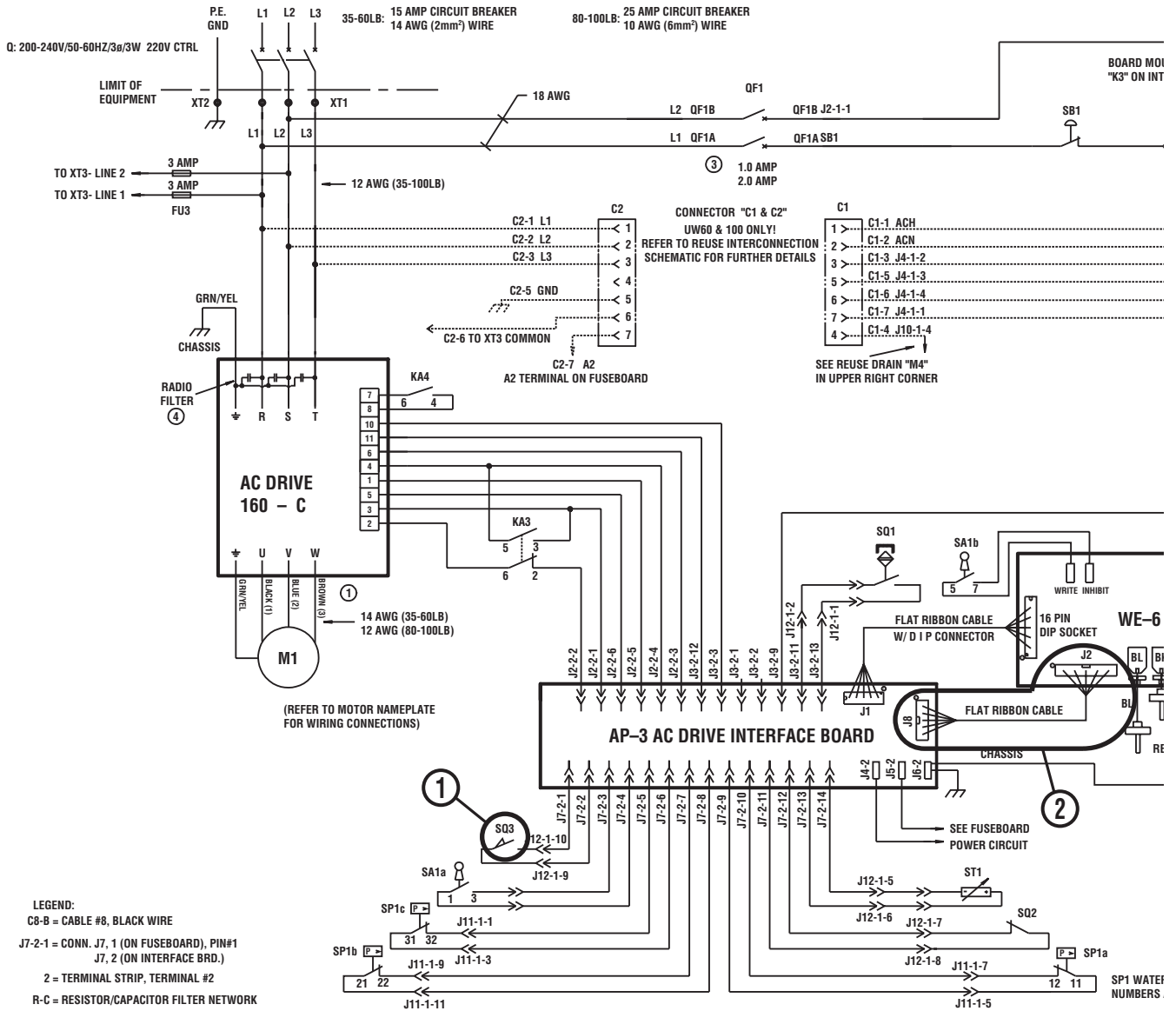

- NOTES:**
- 1 THE DRIVE MOTOR (M1) IS DUAL VOLTAGE CAPABLE. REFER TO NAMEPLATE OF MOTOR BEFORE WIRING. IF MOTOR ROTATION IS INCORRECT, SWAP ANY 2 WIRES OF CABLE BETWEEN AC DRIVE AND MOTOR.
 - 2 REFER TO PROGRAMMING MANUAL FOR DETAILED INSTRUCTIONS TO OPERATE SUPPLIES. SUPPLY 5 OUTPUT PROVIDES POWER TO ACTIVATE RELAYS KA1 & KA2 IN ORDER TO ENABLE EXTERNAL SUPPLIES 6 THROUGH 9. EXAMPLE: IF SUPPLY 1 IS PROGRAMMED, THE SUPPLY 1 OUTPUT PROVIDES A 220V SIGNAL TO EXTERNAL SUPPLY 1. WHEN SUPPLY 5 IS PROGRAMMED WITH SUPPLY 1, THE SUPPLY 1 OUTPUT THEN PROVIDES A 220V SIGNAL TO EXTERNAL SUPPLY 6.
 - 3 UW80-100 MACHINES WITH DUAL ELECTRICALLY OPERATED DRAIN VALVES REQUIRE TWO 2 AMP, 250V CONTROL CIRCUIT BREAKERS (QF1). LIKEWISE FOR REUSE DRAIN M4. ALL MACHINES WITH SINGLE ELECTRIC DRAIN VALVES REQUIRE TWO 1 AMP, 250V CONTROL CIRCUIT BREAKERS (QF1).
 - 4 AN ADDITIONAL FILTER (P/N 635654) IS REQUIRED ACROSS THE INPUT OF THE AC DRIVE.

Door Lock Switch Analysis The WE-6 Display Reads "Close Door" (Sheet 2 of 2)

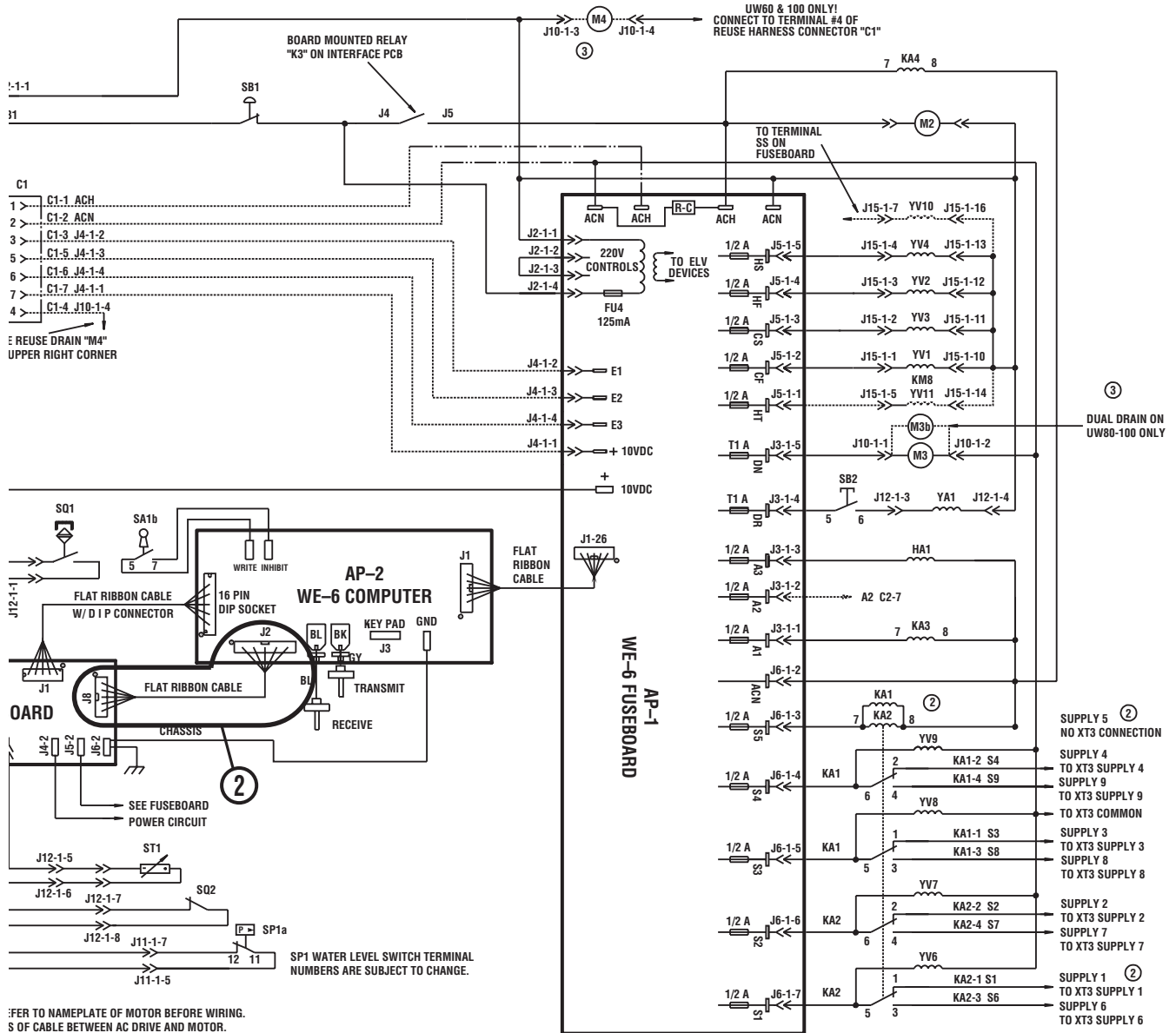

REFER TO NAMEPLATE OF MOTOR BEFORE WIRING.
CHECK POLARITY OF CABLE BETWEEN AC DRIVE AND MOTOR.

INSTRUCTIONS TO OPERATE SUPPLIES:
RELAYS KA1 & KA2 IN ORDER TO ENABLE EXTERNAL PROGRAMMED, THE SUPPLY 1 OUTPUT PROVIDES A COMMON IS PROGRAMMED WITH SUPPLY 1, THE SUPPLY 1 SUPPLY 6.

INSTALLED DRAIN VALVES REQUIRE TWO 2 AMP, 250V
FUSE DRAIN M4.
DRAIN VALVES REQUIRE TWO 1 AMP, 250V

DO NOT EXCEED THE INPUT OF THE AC DRIVE.

EXTERNAL SUPPLY TERMINAL STRIP (XT3) LOCATED ON REAR OF MODULE.
EXTERNAL SUPPLY 5 INTENTIONALLY OMITTED. SUPPLY 5 ENERGIZES RELAYS KA1 & KA2 TO ENABLE SUPPLIES 6 THRU 9.
THIS COMMON IS NOT A TRUE NEUTRAL.
DO NOT CONNECT LOAD BETWEEN LINE 1, LINE 2 OR LINE 3 AND THIS COMMON.
220V BETWEEN ALL LINES AND COMMON.

PHM1919S

Section 4 Troubleshooting

6. NO FUSEBOARD FUNCTIONS

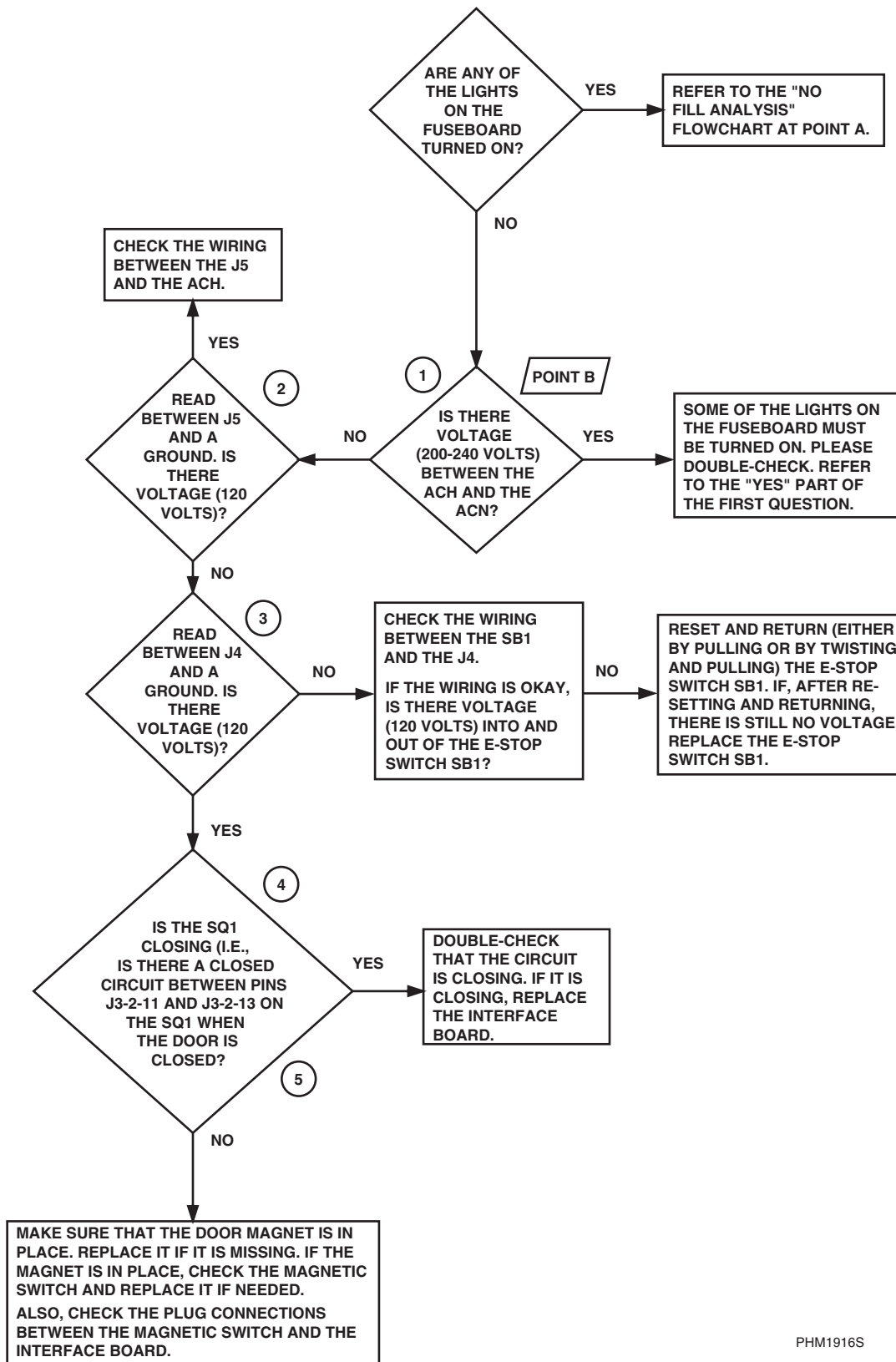

PHM1916S

Please refer to the following 2 pages for wiring diagram information.

Section 4 Troubleshooting

No Fuseboard Functions (Sheet 1 of 2)

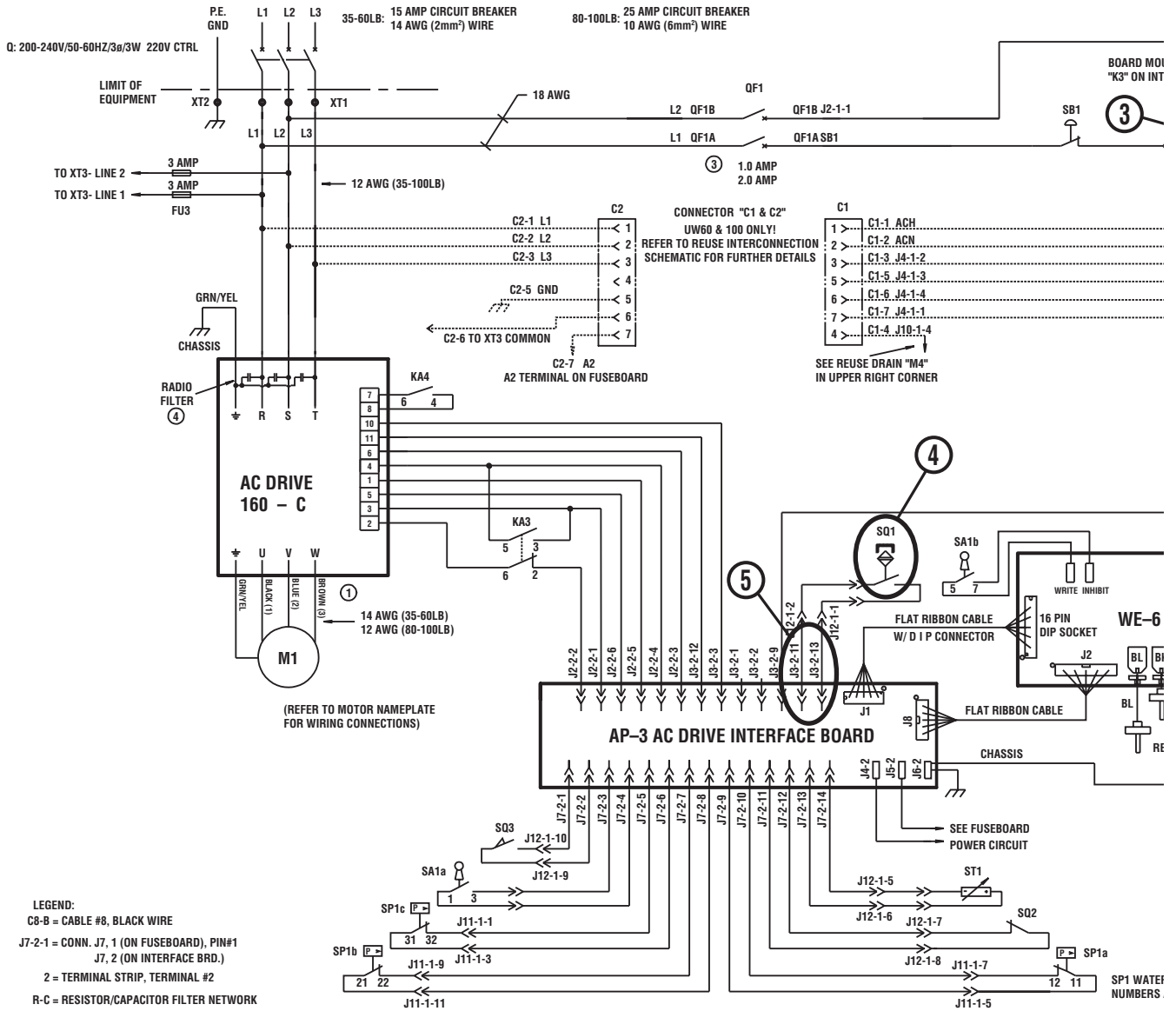

No Fuseboard Functions (Sheet 2 of 2)

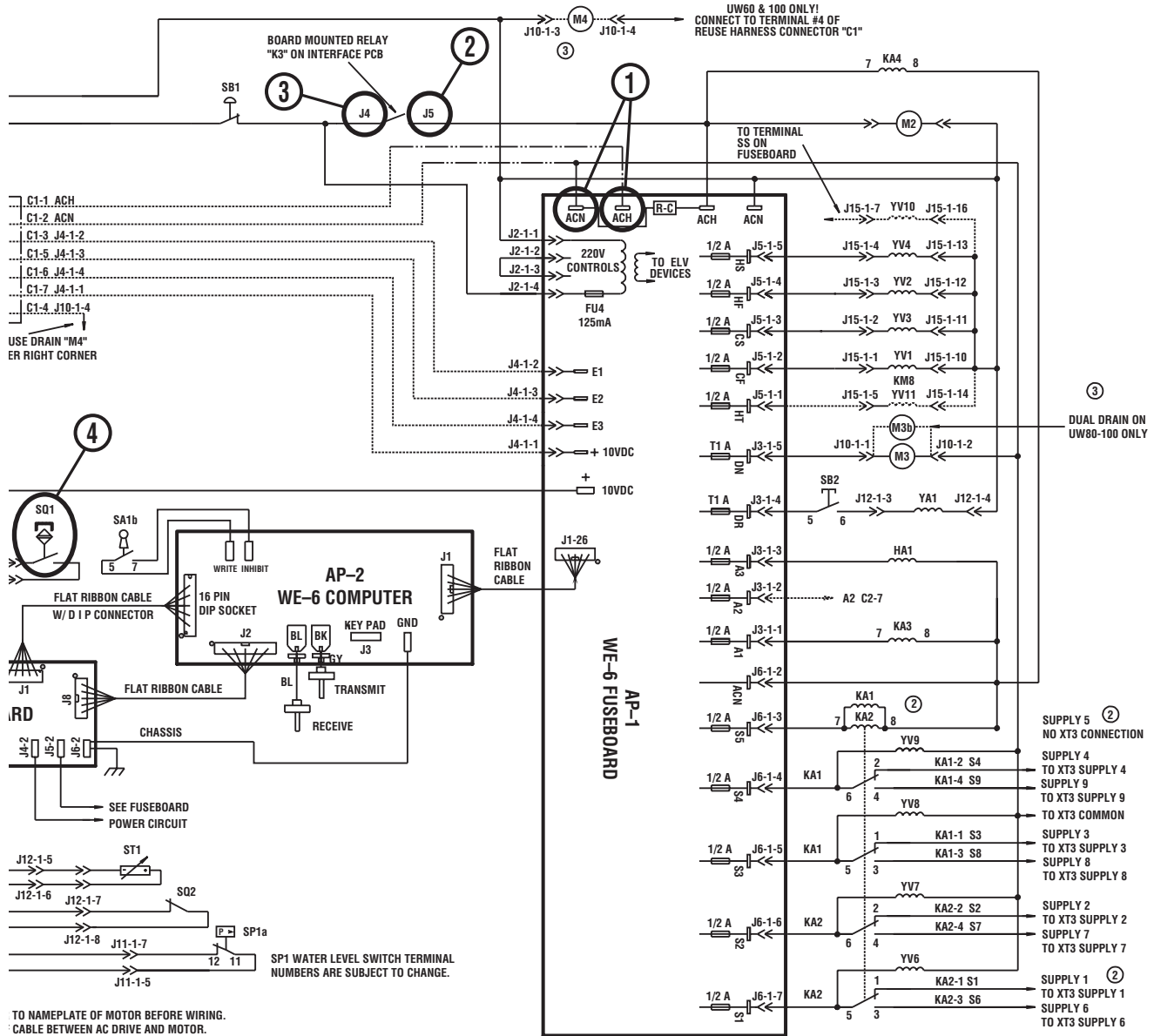

TO NAMEPLATE OF MOTOR BEFORE WIRING. CABLE BETWEEN AC DRIVE AND MOTOR.

INSTRUCTIONS TO OPERATE SUPPLIES. KA1 & KA2 IN ORDER TO ENABLE EXTERNAL IMMEDIATE, THE SUPPLY 1 OUTPUT PROVIDES A PROGRAMMED WITH SUPPLY 1, THE SUPPLY 1 PLY 6.

1 DRAIN VALVES REQUIRE TWO 2 AMP, 250V DRAIN M4. WIRE TWO 1 AMP, 250V

THE INPUT OF THE AC DRIVE.

EXTERNAL SUPPLY TERMINAL STRIP (XT3) LOCATED ON REAR OF MODULE. EXTERNAL SUPPLY 5 INTENTIONALLY OMITTED. SUPPLY 5 ENERGIZES RELAYS KA1 & KA2 TO ENABLE SUPPLIES 6 THRU 9. THIS COMMON IS NOT A TRUE NEUTRAL. DO NOT CONNECT LOAD BETWEEN LINE 1, LINE 2 OR LINE 3 AND THIS COMMON. 220V BETWEEN ALL LINES AND COMMON.

PHM1917S

Section 4 Troubleshooting

7. NO MOTOR OPERATION (WITH NO AC DRIVE FAULT)

Symptom: The motor is not running and there is no apparent AC drive fault present.

Refer to reference point “1” on the following “No Motor Operation (With No AC Drive Fault)” schematics.

Preliminary Checks:

- a. Check for any mechanical problems in the drive system (e.g., check the motor, motor bearings, pulleys and belt).
- b. Check all electrical connections between the interface board and the AC drive.
- c. Check for proper control signal wiring.

Secondary Checks:

- a. Check for incoming AC voltage into the AC drive.
- b. Using a parameter unit, check the parameter set for your motor/AC drive combination.

NOTE: Contact the factory with your washer-extractor’s model and serial number to obtain the proper AC drive illustration.

- c. Check the control signals between the interface board and the AC drive with the voltage test shown on the following charts.

A-B 160 Control Logic

H – Control Voltage High 12 Volts DC		Logic 0															
L – Control Voltage Low <1 Volt DC		Logic 1															
Voltage Reading Pos (+) Volts DC		4	2	1	6	8	5	Input Status									
Voltage Reading Neg (-) Volts DC		3	3	3	3	3	3	Parameter 15				Parameter 12					
V Computer & EDC																	
Action	A-B 160 Frequency Preset Parameter	Preset #	Preset Input/SW3	Preset Input/SW2	Preset Input/SW1	Forward Motion/STF	Stop	Reverse Motion/STR	N/A	SW3	SW2	SW1	N/A	STF	Stop	STR	
Half Wash Fwd	62	1	H	H	L	L	L	H	0	0	0	1	0	1	1	0	
Half Wash Rev	62	1	H	H	L	H	L	L	0	0	0	1	0	0	1	1	
Wash Fwd	63	2	H	L	H	L	L	H	0	0	1	0	0	1	1	0	
Wash Rev	63	2	H	L	H	H	L	L	0	0	1	0	0	0	1	1	
Distribution	65	4	L	H	H	L	L	H	0	1	0	0	0	1	1	0	
Spin 1	64	3	H	L	L	L	L	H	0	0	1	1	0	1	1	0	
Spin 2	67	6	L	L	H	L	L	H	0	1	1	0	0	1	1	0	
Spin 3	66	5	L	H	L	L	L	H	0	1	0	1	0	1	1	0	
WE-6 Computer																	
Half Wash Fwd	65	4	L	H	H	L	L	H	0	1	0	0	0	1	1	0	
Half Wash Rev	65	4	L	H	H	H	L	L	0	1	0	0	0	0	1	1	
Wash Fwd	63	2	H	L	H	L	L	H	0	0	1	0	0	1	1	0	
Wash Rev	63	2	H	L	H	H	L	L	0	0	1	0	0	0	1	1	
Distribution	62	1	H	H	L	L	L	H	0	0	0	0	0	1	1	0	
Med. Spin	67	6	L	L	H	L	L	H	0	1	1	0	0	1	1	0	
High Spin 1	66	5	L	H	L	L	L	H	0	1	0	1	0	1	1	0	
High Spin 2	64	3	H	L	L	L	L	H	0	0	1	1	0	1	1	0	
High Spin 3	68	7	L	L	L	L	L	H	0	1	1	1	0	1	1	0	

A-B 1305 Control Logic

H – Control Voltage High 5 Volts DC			Logic 0													
L – Control Voltage Low <1 Volt DC			Logic 1													
Voltage Reading Pos (+) Volts DC		18	17	19	13	8	6	Input Status Parameter 55								
Voltage Reading Neg (-) Volts DC		7	7	7	7	7	7									
V Computer & EDC																
Action	A-B 1305 Frequency Preset Parameter	Preset #	Preset Input/ SW3	Preset Input/ SW2	Preset Input/ SW1	Reverse Motion/ STR	Stop	Forward Motion/ STF	X	SW3	SW2	SW1	N/A	STR	Stop	STF
Half Wash Fwd	27	1	H	H	L	H	L	L	x	0	0	1	0	0	1	1
Half Wash Rev	27	1	H	H	L	L	L	H	x	0	0	1	0	1	1	0
Wash Fwd	28	2	H	L	H	H	L	L	x	0	1	0	0	0	1	1
Wash Rev	28	2	H	L	H	L	L	H	x	0	1	0	0	1	1	0
Distribution	73	4	L	H	H	H	L	L	x	1	0	0	0	0	1	1
Spin 1	29	3	H	L	L	H	L	L	x	0	1	1	0	0	1	1
Spin 2	75	6	L	L	H	H	L	L	x	1	1	0	0	0	1	1
Spin 3	74	5	L	H	L	H	L	L	x	1	0	1	0	0	1	1
WE-6 Computer																
Half Wash Fwd	73	4	L	H	H	H	L	L	x	1	0	0	0	0	1	1
Half Wash Rev	73	4	L	H	H	L	L	H	x	1	0	0	0	1	1	0
Wash Fwd	28	2	H	L	H	H	L	L	x	0	1	0	0	0	1	1
Wash Rev	28	2	H	L	H	L	L	H	x	0	1	0	0	1	1	0
Distribution	27	1	H	H	L	H	L	L	x	0	0	1	0	0	1	1
Med. Spin	75	6	L	L	H	H	L	L	x	1	1	0	0	0	1	1
High Spin 1	74	5	L	H	L	H	L	L	x	1	0	1	0	0	1	1
High Spin 2	29	3	H	L	L	H	L	L	x	0	1	1	0	0	1	1
High Spin 3	76	7	L	L	L	H	L	L	x	1	1	1	0	0	1	1

Section 4 Troubleshooting

A-B 1336 Control Logic

H – Control Voltage High 5 Volts DC			Logic 0															
L – Control Voltage Low <1 Volt DC			Logic 1															
Voltage Reading Pos (+) Volts DC		27	28	26	22	20	19	Input Status Parameter #55										
Voltage Reading Neg (-) Volts DC		29	29	29	29	29	29											
V Computer																		
Action	A-B 1336 Frequency Preset Parameter	Preset #	Preset Input/SW2	Preset Input/SW1	Preset Input/SW3	Reverse Motion/STR	Stop	Forward Motion/STF	SW2	SW1	SW3	MTR TEMP	STR	N/A	STOP	STF		
Half Wash Fwd	73	4	H	H	L	H	L	L	0	0	1	1	0	0	1	1		
Half Wash Rev	73	4	H	H	L	L	L	H	0	0	1	1	1	0	1	0		
Wash Fwd	28	2	L	H	H	H	L	L	1	0	0	1	0	0	1	1		
Wash Rev	28	2	L	H	H	L	L	H	1	0	0	1	1	0	1	0		
Distribution	27	1	H	L	H	H	L	L	0	1	0	1	0	0	1	1		
Spin 1	75	6	L	H	L	H	L	L	1	0	1	1	0	0	1	1		
Spin 2	29	3	L	L	H	H	L	L	1	1	0	1	0	0	1	1		
Spin 3	74	5	H	L	L	H	L	L	0	1	1	1	0	0	1	1		
WE-6 Controller																		
Half Wash Fwd	73	4	H	H	L	H	L	L	0	0	1	1	0	0	1	1		
Half Wash Rev	73	4	H	H	L	L	L	H	0	0	1	1	1	0	1	0		
Wash Fwd	28	2	L	H	H	H	L	L	1	0	0	1	0	0	1	1		
Wash Rev	28	2	L	H	H	L	L	H	1	0	0	1	1	0	1	0		
Distribution	27	1	H	L	H	H	L	L	0	1	0	1	0	0	1	1		
Med. Spin	75	6	L	H	L	H	L	L	1	0	1	1	0	0	1	1		
High Spin 1	74	5	H	L	L	H	L	L	0	1	1	1	0	0	1	1		
High Spin 2	29	3	L	L	H	H	L	L	1	1	0	1	0	0	1	1		
High Spin 3	76	7	L	L	L	H	L	L	1	1	1	1	0	0	1	1		

Please refer to the following 4 pages for wiring diagram information.

Section 4 Troubleshooting

No Motor Operation (With No AC Drive Fault)
P and N-Voltage Models (Sheet 1 of 2)

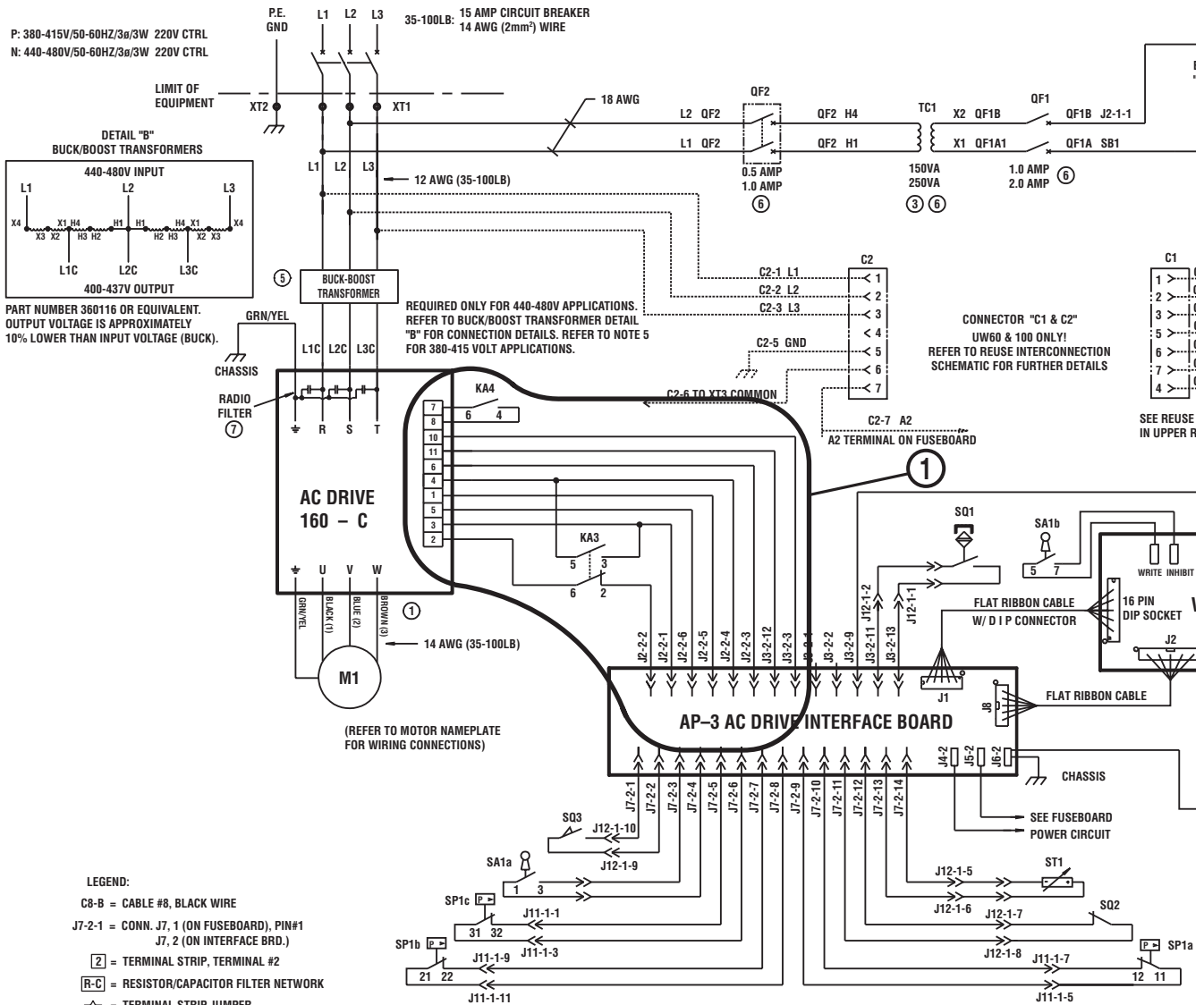

- NOTES:**
- 1 THE DRIVE MOTOR (M1) IS DUAL VOLTAGE CAPABLE. REFER TO NAMEPLATE OF MOTOR BEFORE WIRING. IF MOTOR ROTATION IS INCORRECT, SWAP ANY 2 WIRES OF CABLE BETWEEN AC DRIVE AND MOTOR.
 - 2 REFER TO PROGRAMMING MANUAL FOR DETAILED INSTRUCTIONS TO OPERATE SUPPLIES. SUPPLY 5 OUTPUT PROVIDES POWER TO SWITCH RELAYS KA1 & KA2 IN ORDER TO ENABLE EXTERNAL SUPPLIES 6 THROUGH 9. EXAMPLE: IF SUPPLY 1 IS PROGRAMMED, THE SUPPLY 1 OUTPUT PROVIDES A 220V SIGNAL TO EXTERNAL SUPPLY 1. WHEN SUPPLY 5 IS PROGRAMMED WITH SUPPLY 1, THE SUPPLY 1 OUTPUT THEN PROVIDES A 220V SIGNAL TO EXTERNAL SUPPLY 6.
 - 3 REFER TO DWG. #635635 FOR CONNECTION DETAILS OF CONTROL TRANSFORMER.
 - 4 AIR OPERATED DRAIN SYSTEM AVAILABLE AS AN OPTION
 - 5 380-415V APPLICATIONS DO NOT REQUIRE BUCK-BOOST TRANSFORMERS. WIRES L1, L2 & L3 WILL CONNECT DIRECTLY TO AC DRIVE FROM INPUT POWER DISTRIBUTION TERMINAL XT1. FOR 440-480V APPLICATIONS, REFER TO BUCK-BOOST TRANSFORMER SCHEMATIC FOR CONNECTION DETAILS.
 - 6 UW80-100 MACHINES WITH DUAL ELECTRICALLY OPERATED DRAIN VALVES REQUIRE A 250VA CONTROL TRANSFORMER (TC1), TWO AMP 250VA CONTROL CIRCUIT BREAKERS (QF1) AND A 1.0 AMP TRANSFORMER PRIMARY (QF2) CIRCUIT BREAKER. ALL MACHINES WITH SINGLE ELECTRICALLY OPERATED DRAIN VALVE REQUIRE A 150VA XFMR, TWO 1 AMP CONTROL CIRCUIT BREAKERS (QF1) AND A 0.5 AMP TRANSFORMER PRIMARY CIRCUIT BREAKER (QF2). ALL AIR-OP DRAIN SYSTEMS REQUIRE 150VA XFMR.
 - 7 AN ADDITIONAL FILTER (P/N 635654) IS REQUIRED ACROSS THE INPUT OF THE AC DRIVE.

No Motor Operation (With No AC Drive Fault) P and N-Voltage Models (Sheet 2 of 2)

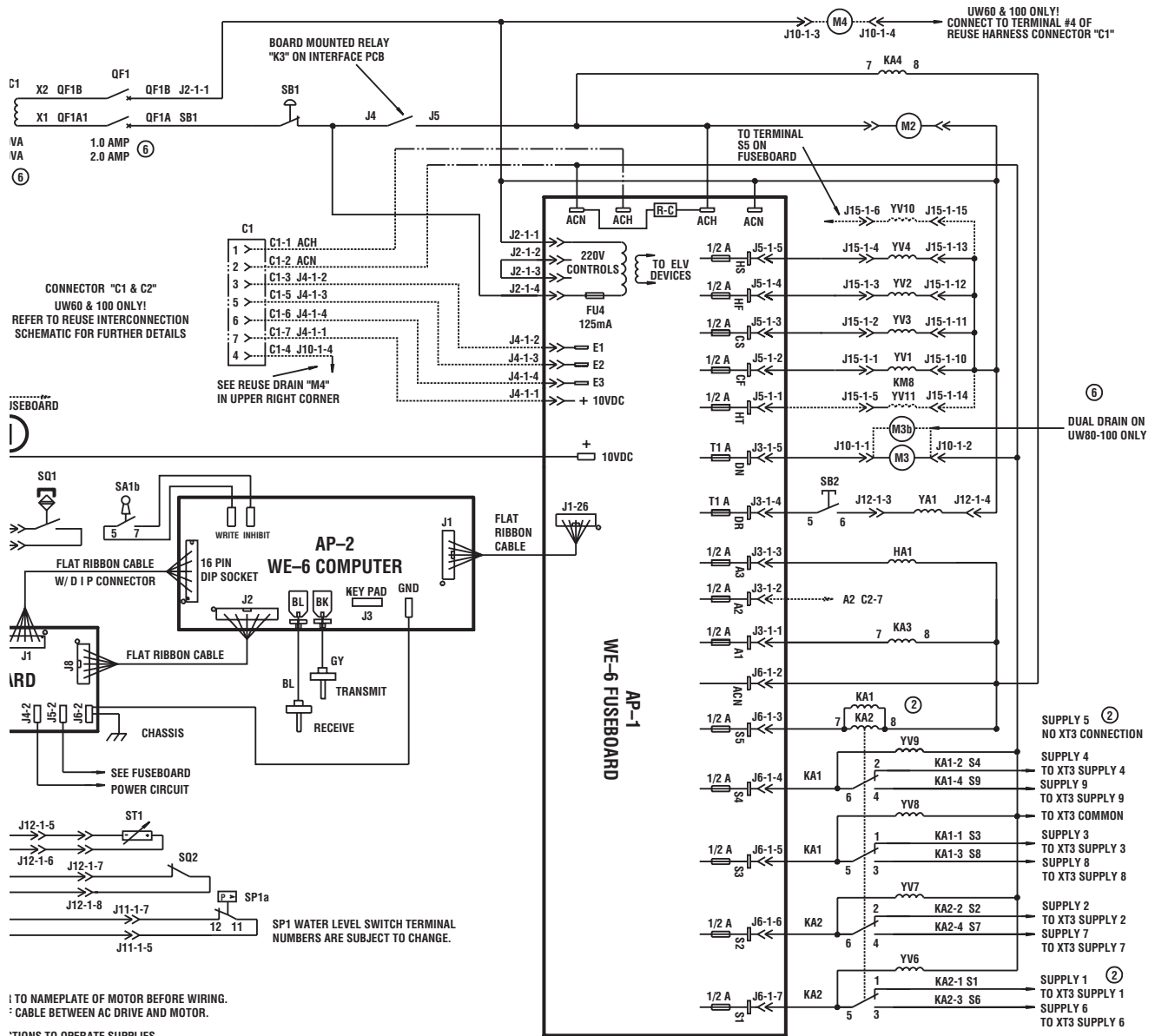

1 TO NAMEPLATE OF MOTOR BEFORE WIRING.
 2 CABLE BETWEEN AC DRIVE AND MOTOR.
 3 INSTRUCTIONS TO OPERATE SUPPLIES.
 4 KA1 & KA2 IN ORDER TO ENABLE EXTERNAL
 5 PROGRAMMED WITH SUPPLY 1, THE SUPPLY 1
 6 SUPPLY 6.
 7 CONTROL TRANSFORMER.
 8 TRANSFORMERS. WIRES L1, L2 & L3 WILL CONNECT
 9 TO TERMINAL XT1.
 10 TRANSFORMER SCHEMATIC FOR CONNECTION DETAILS.
 11 DRAIN VALVES REQUIRE A 250VA CONTROL
 12 TRANSFORMER PRIMARY CIRCUIT BREAKER (QF2).
 13 MAIN VALVE REQUIRE A 150VA XFMR, TWO 1 AMP
 14 CIRCUIT BREAKER (QF1) AND A 1.0 AMP TRANSFORMER
 15 THE INPUT OF THE AC DRIVE.

EXTERNAL SUPPLY TERMINAL STRIP (XT3) LOCATED ON REAR OF MODULE.
 EXTERNAL SUPPLY 5 INTENTIONALLY OMITTED. SUPPLY 5 ENERGIZES RELAYS KA1 & KA2
 TO ENABLE SUPPLIES 6 THRU 9.
 THIS COMMON IS NOT A TRUE NEUTRAL.
 DO NOT CONNECT LOAD BETWEEN LINE 1,
 LINE 2 OR LINE 3 AND THIS COMMON.
 220V BETWEEN ALL LINES AND COMMON.

PHM1937S

Section 4 Troubleshooting

No Motor Operation (With No AC Drive Fault)
Q-Voltage Models (Sheet 1 of 2)

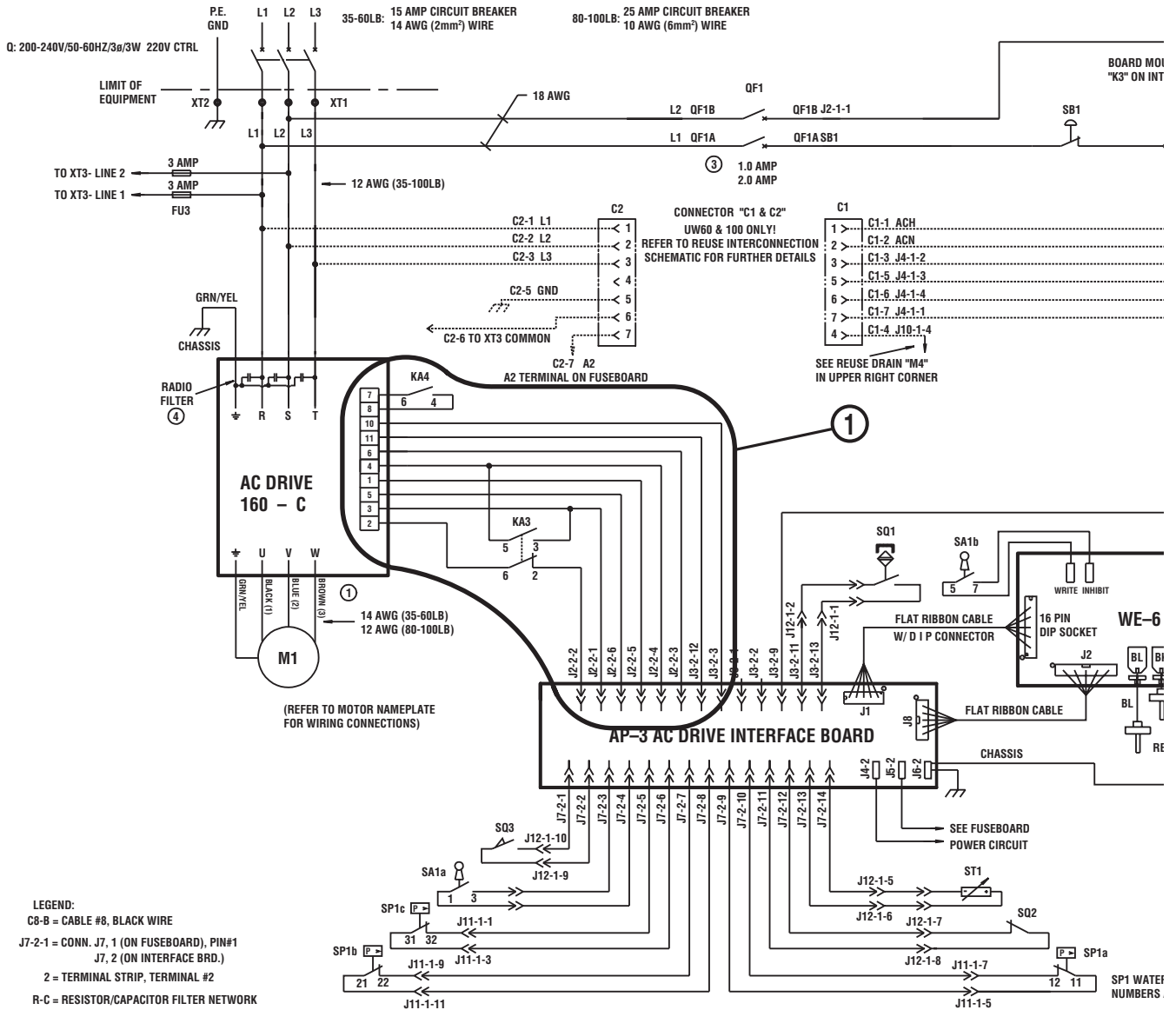

LEGEND:
 C8-B = CABLE #8, BLACK WIRE
 J7-2-1 = CONN. J7, 1 (ON FUSEBOARD), PIN#1
 J7, 2 (ON INTERFACE BRD.)
 2 = TERMINAL STRIP, TERMINAL #2
 R-C = RESISTOR/CAPACITOR FILTER NETWORK
 Δ = TERMINAL STRIP JUMPER
 (TERMINAL STRIP JUMPERS MAY BE USED IN VARIOUS PLACES NOT SHOWN ON SCHEMATIC)

TYPICAL RELAY

	NORMALLY CLOSED CONTACTS
	NORMALLY OPEN CONTACTS
	COMMON
	COIL

ODD NUMBERED CONTACTS ARE ISOLATED FROM EVEN NUMBERED CONTACTS BUT OPERATE SIMULTANEOUSLY. TERMINAL NUMBERS MAY VARY FROM RELAY TO RELAY BUT TERMINAL POSITIONS ARE THE SAME.

NOTES:

- 1 THE DRIVE MOTOR (M1) IS DUAL VOLTAGE CAPABLE. REFER TO NAMEPLATE OF MOTOR BEFORE WIRING. IF MOTOR ROTATION IS INCORRECT, SWAP ANY 2 WIRES OF CABLE BETWEEN AC DRIVE AND MOTOR.
- 2 REFER TO PROGRAMMING MANUAL FOR DETAILED INSTRUCTIONS TO OPERATE SUPPLIES. SUPPLY 5 OUTPUT PROVIDES POWER TO ACTIVATE RELAYS KA1 & KA2 IN ORDER TO ENABLE EXTERNAL SUPPLIES 6 THROUGH 9. EXAMPLE: IF SUPPLY 1 IS PROGRAMMED, THE SUPPLY 1 OUTPUT PROVIDES A 220V SIGNAL TO EXTERNAL SUPPLY 1. WHEN SUPPLY 5 IS PROGRAMMED WITH SUPPLY 1, THE SUPPLY 1 OUTPUT THEN PROVIDES A 220V SIGNAL TO EXTERNAL SUPPLY 6.
- 3 UW80-100 MACHINES WITH DUAL ELECTRICALLY OPERATED DRAIN VALVES REQUIRE TWO 2 AMP, 250V CONTROL CIRCUIT BREAKERS (QF1). LIKEWISE FOR REUSE DRAIN M4. ALL MACHINES WITH SINGLE ELECTRIC DRAIN VALVES REQUIRE TWO 1 AMP, 250V CONTROL CIRCUIT BREAKERS (QF1).
- 4 AN ADDITIONAL FILTER (P/N 635654) IS REQUIRED ACROSS THE INPUT OF THE AC DRIVE.

No Motor Operation (With No AC Drive Fault) Q-Voltage Models (Sheet 2 of 2)

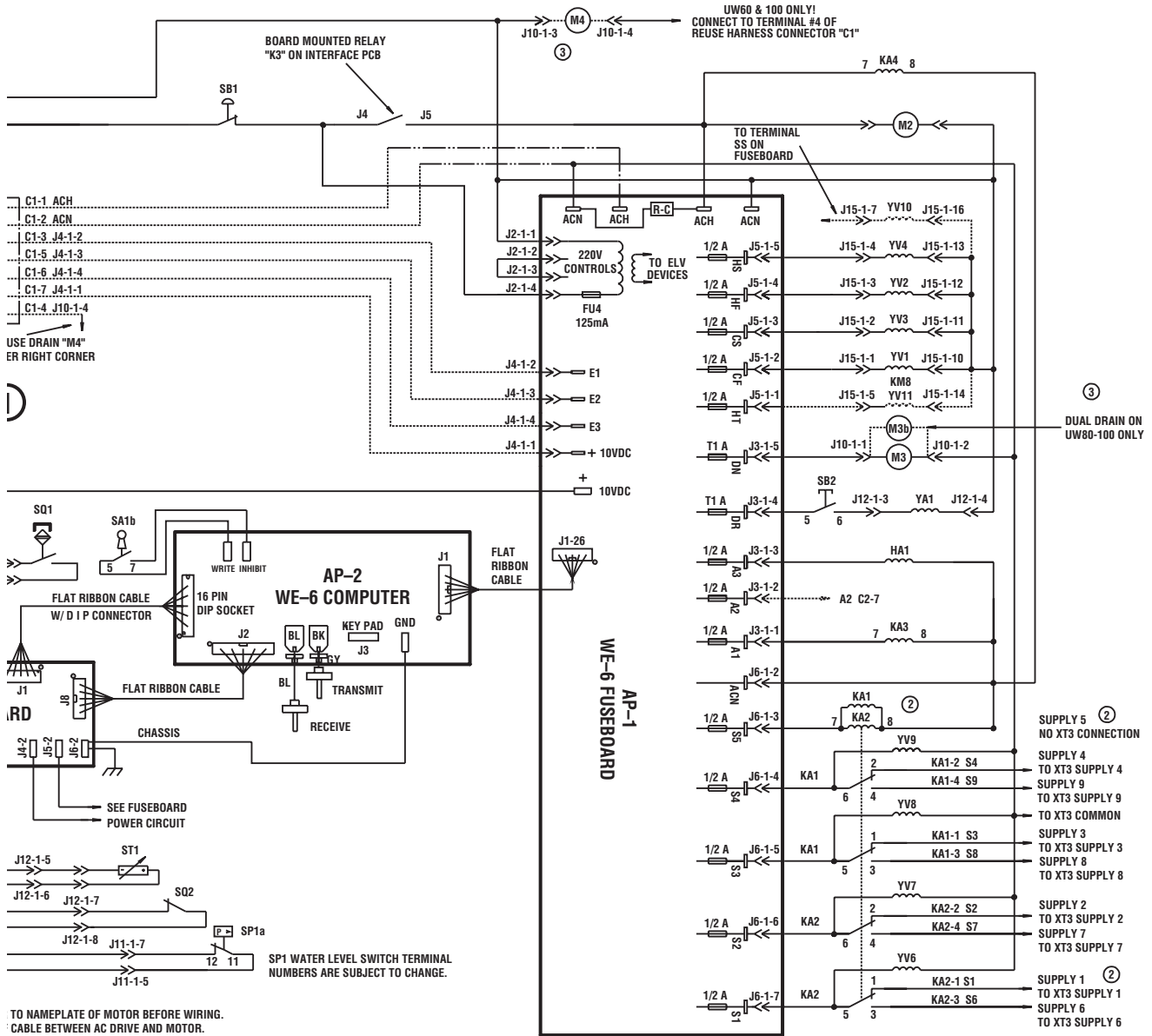

C1-1 ACH
C1-2 ACN
C1-3 J4-1-2
C1-5 J4-1-3
C1-6 J4-1-4
C1-7 J4-1-1
C1-4 J10-1-4

USE DRAIN "M4"
ER RIGHT CORNER

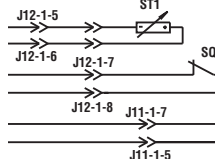
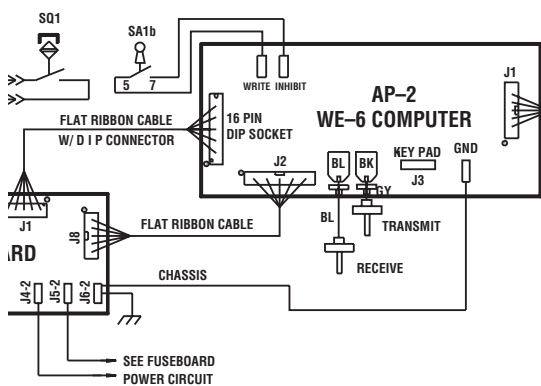

TO NAMEPLATE OF MOTOR BEFORE WIRING.
CABLE BETWEEN AC DRIVE AND MOTOR.

CTIONS TO OPERATE SUPPLIES.
KA1 & KA2 IN ORDER TO ENABLE EXTERNAL
IMMED, THE SUPPLY 1 OUTPUT PROVIDES A
ROGRAMMED WITH SUPPLY 1, THE SUPPLY 1
PLY 6.

I DRAIN VALVES REQUIRE TWO 2 AMP, 250V
RAIN IM4.
JIRE TWO 1 AMP, 250V

THE INPUT OF THE AC DRIVE.

EXTERNAL SUPPLY TERMINAL STRIP (XT3) LOCATED ON REAR OF MODULE.
EXTERNAL SUPPLY 5 INTENTIONALLY OMITTED. SUPPLY 5 ENERGIZES RELAYS KA1 & KA2
TO ENABLE SUPPLIES 6 THRU 9.
THIS COMMON IS NOT A TRUE NEUTRAL.
DO NOT CONNECT LOAD BETWEEN LINE 1,
LINE 2 OR LINE 3 AND THIS COMMON.
220V BETWEEN ALL LINES AND COMMON.

Section 4 Troubleshooting

8. NO MOTOR OPERATION (WITH AC DRIVE FAULT)

Symptom: The motor is not running and there is an apparent AC drive fault present.

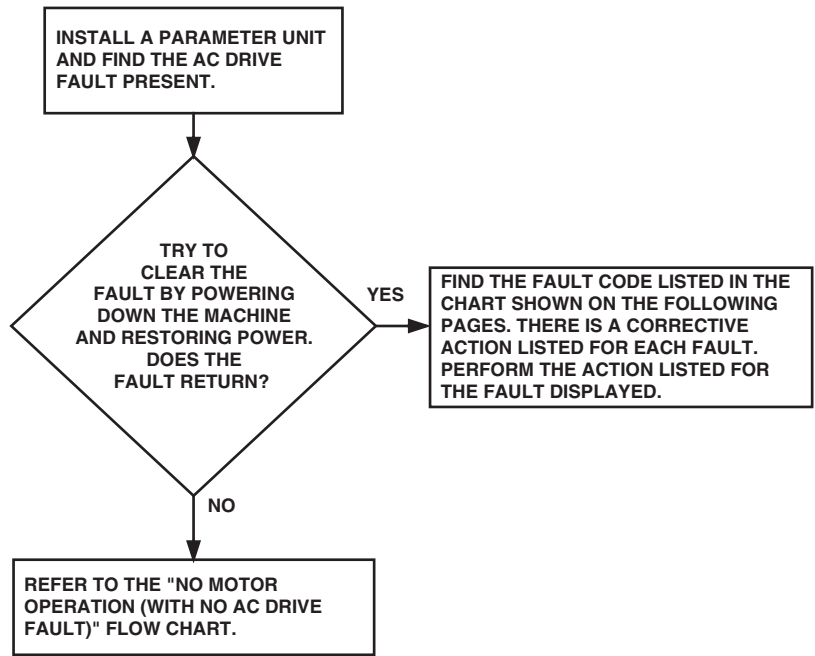

PHM1936S

9. THE MOTOR IS RUNNING, BUT AT AN ABNORMAL SPEED

Preliminary Checks:

- a. Check all electrical connections between the interface board and the AC drive. Refer to reference point “1” on the “No Motor Operation (with No AC Drive Fault)” schematic.

Secondary Checks:

- a. Using a parameter unit, check the parameter set for your motor/AC drive combination.

NOTE: Contact the factory with your washer-extractor’s model and serial number to obtain the proper AC drive illustration.

- b. Check the control signals between the interface board and the AC drive with the voltage test shown on the charts included on the following pages.

Section 4 Troubleshooting

AC Drive Fault Codes and Troubleshooting Information

Bulletin 160	Bulletin 1305	Bulletin 1336	Fault	Description	Corrective Action/Remarks
		02	Motor Temp Fault	The motor thermal switch path is open.	Motor temperature high. Check for: ambient air, cooling fan blockage or operation, break in switch wire path (not on all machines).
03	03	03	Power Loss Fault	DC Bus voltage remains below 85% nominal for longer than 0.005 seconds.	Monitor incoming AC line for low voltage or line power interruption.
04	04	04	Under Voltage Fault	DC Bus voltage fell below minimum.	Monitor AC incoming AC line for low voltage or line power interruption.
05	05	05	Over Voltage Fault	DC Bus maximum voltage exceeded.	Monitor the AC line for high line voltage or transient conditions. High voltage can result from motor regeneration. Buck transformer may be required.
06	06	06	Motor Stall	Motor has stalled. Motor load is excessive	Check motor wiring and connection terminals. Check wash basket freedom of movement and excess belt tension.
07	07	07	Motor Overload Fault	Internal electronic overload trip. Excessive motor load exists.	Check motor wiring and connection terminals. Check wash basket freedom of movement and excess belt tension.
08	08	08	Over Temperature Fault	Excessive heat detected by heatsink transducer.	Clear blocked or dirty heatsink fins. Check ambient temperature. Check for blocked or nonoperating fan.
	10	10	Serial Fault	Drive lost communication with controlling device.	HIM removed while power applied, cycle power to clear.
12	12	12	Overcurrent Fault	Overcurrent detected in instantaneous hardware trip circuit.	Check short circuit at the controller output or excessive load conditions at motor.
22	22	22	Controller Reset Fault	Stop input not present.	Check stop input into control terminal board. Close door and ensure any jumpers are placed correctly.
32	32	32	EEPROM Fault	EEProm has invalid data.	Consult the factory for further instructions.
33	33	33	Max Retries Fault	Controller failed to reset fault within the number of retries.	Fault exists that must be corrected before further operation. Check "Fault Buffer 1" on 1305 and 1336 for specific fault that triggered max retries fault.
38	38	38	Phase U Fault	Phase-to-ground fault detected between controller and motor in Phase U.	Check wiring between the drive and motor. Check for grounded phase.
39	39	39	Phase V Fault	Phase to ground fault detected between controller and motor in Phase V.	Check wiring between the drive and motor. Check for grounded phase.
40	40	40	Phase W Fault	Phase to ground fault detected between controller and motor in Phase W.	Check wiring between the drive and motor. Check for grounded phase.

AC Drive Fault Codes and Troubleshooting Information (continued)

Bulletin 160	Bulletin 1305	Bulletin 1336	Fault	Description	Corrective Action/Remarks
41	41	41	UV Short Fault	Excessive current has been detected between two controller output terminals.	Check motor and external wiring to the controller output terminals for shorted condition.
43	43	43	VW Short Fault	Excessive current has been detected between two controller output terminals.	Check motor and external wiring to the controller output terminals for shorted condition.
	44		IPM Current Fault	Internal power module overcurrent limit exceeded.	Check for short circuit at the drive output or excessive load conditions at the motor, specifically cable capacitance to ground.
	45		IPM Overtemp Fault	Internal power module thermal limit exceeded.	Check for blocked or dirty heatsink fins. Check ambient air. Check fan operation or filter blockage.
		57	Ground Warning	A current path to ground in excess of 2A has been detected at one or more of the drive output terminals.	Check motor and external wiring to drive output terminals for a grounded condition.

Section 4 Troubleshooting

10. NO SPIN

NOTE: While performing this check, make sure that the washer-extractor is running with a normal-size load.

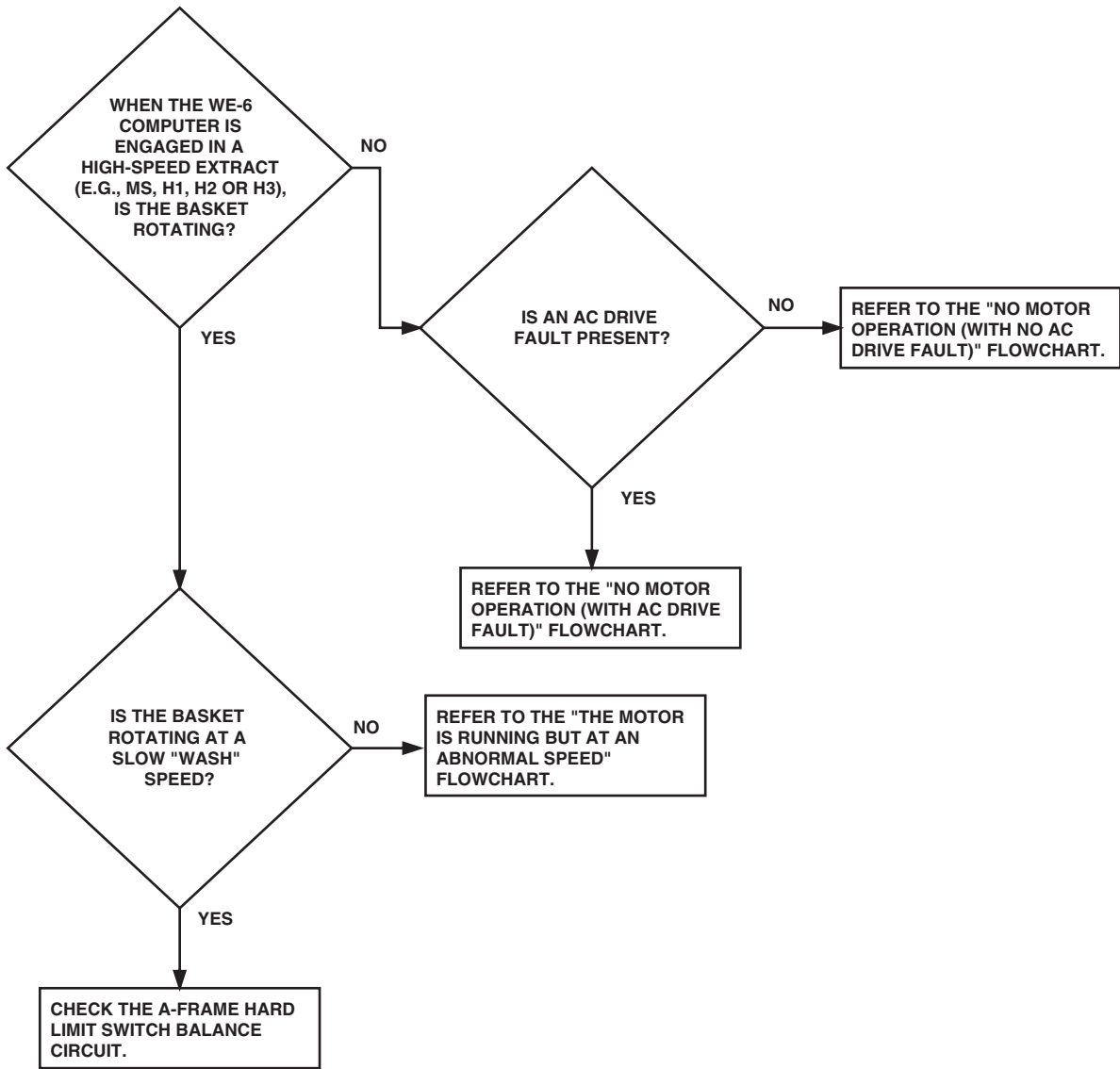

PHM1935S

11. FILL ALARM ANALYSIS

Symptom: The display reads "FILLXX", the signal light illuminates and the buzzer alarms. The computer did not receive an input from the respective water level circuit telling it that the washer-extractor filled in the time programmed.

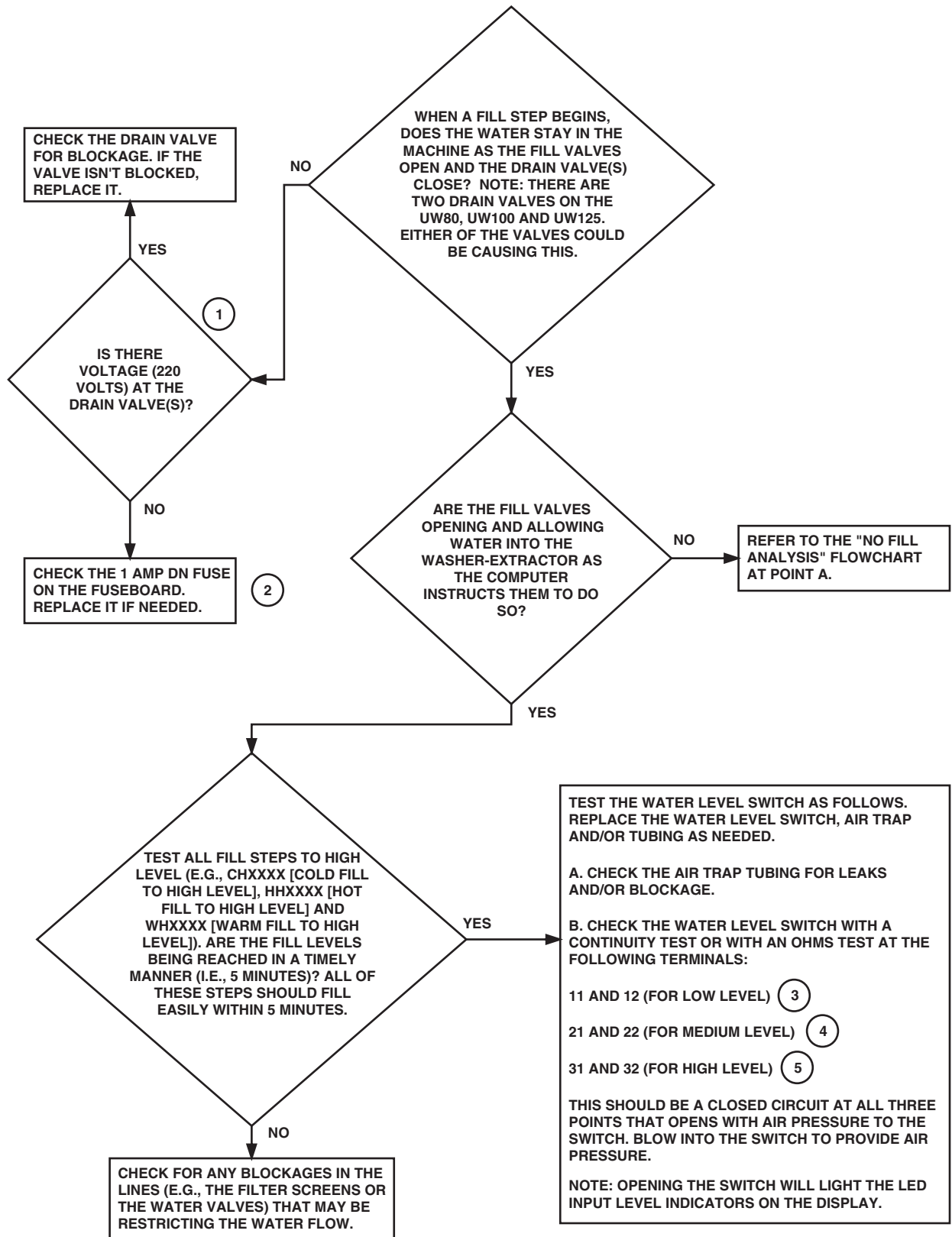

PHM1930S

Please refer to the following 2 pages for wiring diagram information.

Fill Alarm Analysis (Sheet 1 of 2)

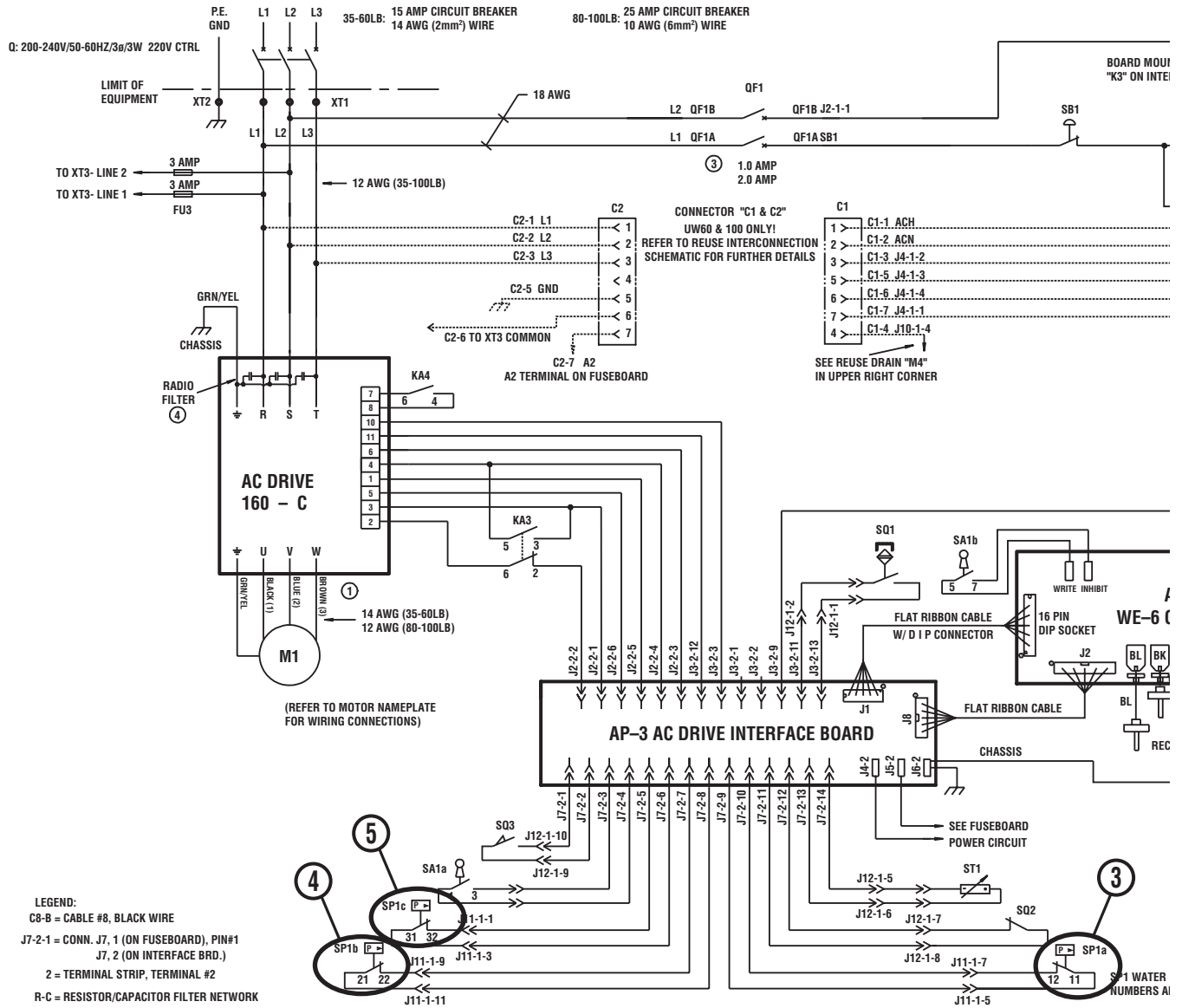

LEGEND:
 C8-B = CABLE #8, BLACK WIRE
 J7-2-1 = CONN. J7, 1 (ON FUSEBOARD), PIN#1
 J7, 2 (ON INTERFACE BRD.)
 2 = TERMINAL STRIP, TERMINAL #2
 R-C = RESISTOR/CAPACITOR FILTER NETWORK
 -△- = TERMINAL STRIP JUMPER
 (TERMINAL STRIP JUMPERS MAY BE USED IN VARIOUS PLACES NOT SHOWN ON SCHEMATIC)

TYPICAL RELAY

--	--	--	--

ODD NUMBERED CONTACTS ARE ISOLATED FROM EVEN NUMBERED CONTACTS BUT OPERATE SIMULTANEOUSLY. TERMINAL NUMBERS MAY VARY FROM RELAY TO RELAY BUT TERMINAL POSITIONS ARE THE SAME.

NOTES:

- THE DRIVE MOTOR (M1) IS DUAL VOLTAGE CAPABLE. REFER TO NAMEPLATE OF MOTOR BEFORE WIRING. IF MOTOR ROTATION IS INCORRECT, SWAP ANY 2 WIRES OF CABLE BETWEEN AC DRIVE AND MOTOR.
- REFER TO PROGRAMMING MANUAL FOR DETAILED INSTRUCTIONS TO OPERATE SUPPLIES. SUPPLY 5 OUTPUT PROVIDES POWER TO ACTIVATE RELAYS KA1 & KA2 IN ORDER TO ENABLE EXTERNAL SUPPLIES 6 THROUGH 9. EXAMPLE: IF SUPPLY 1 IS PROGRAMMED, THE SUPPLY 1 OUTPUT PROVIDES A 220V SIGNAL TO EXTERNAL SUPPLY 1. WHEN SUPPLY 6 IS PROGRAMMED WITH SUPPLY 1, THE SUPPLY 1 OUTPUT THEN PROVIDES A 220V SIGNAL TO EXTERNAL SUPPLY 6.
- UW80-100 MACHINES WITH DUAL ELECTRICALLY OPERATED DRAIN VALVES REQUIRE TWO 2 AMP, 250V CONTROL CIRCUIT BREAKERS (QF1). LIKEWISE FOR REUSE DRAIN M4. ALL MACHINES WITH SINGLE ELECTRIC DRAIN VALVES REQUIRE TWO 1 AMP, 250V CONTROL CIRCUIT BREAKERS (QF1).
- AN ADDITIONAL FILTER (P/N 635654) IS REQUIRED ACROSS THE INPUT OF THE AC DRIVE.

Fill Alarm Analysis (Sheet 2 of 2)

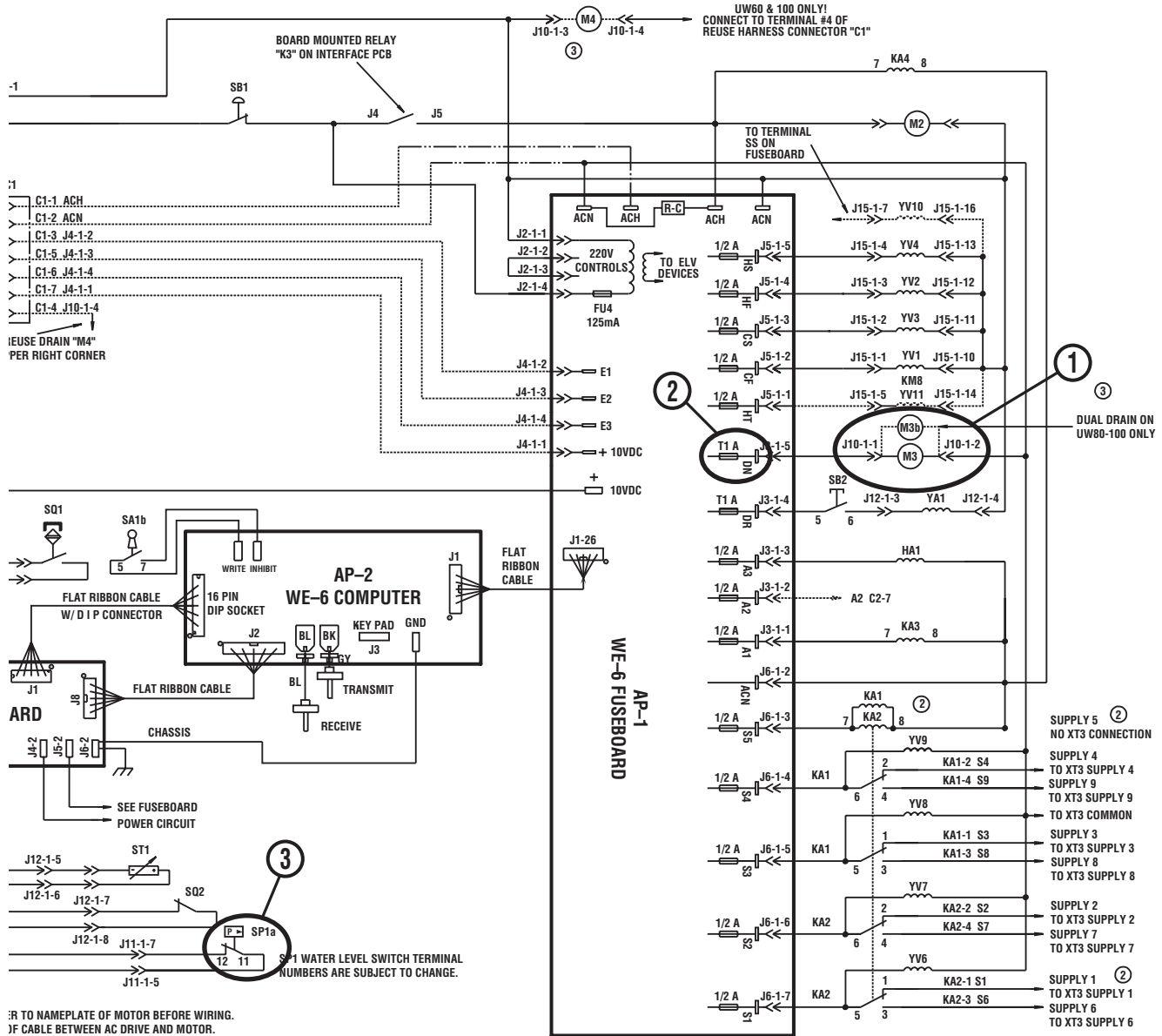

R TO NAMEPLATE OF MOTOR BEFORE WIRING.
 JF CABLE BETWEEN AC DRIVE AND MOTOR.

JCTIONS TO OPERATE SUPPLIES.
 S KA1 & KA2 IN ORDER TO ENABLE EXTERNAL
 RAMMED, THE SUPPLY 1 OUTPUT PROVIDES A
 PROGRAMMED WITH SUPPLY 1, THE SUPPLY 1
 PPLY 6.

ED DRAIN VALVES REQUIRE TWO 2 AMP, 250V
 : DRAIN M4.
 QUIRE TWO 1 AMP, 250V

S THE INPUT OF THE AC DRIVE.

EXTERNAL SUPPLY TERMINAL STRIP (XT3) LOCATED ON REAR OF MODULE.
 EXTERNAL SUPPLY 5 INTENTIONALLY OMITTED. SUPPLY 5 ENERGIZES RELAYS KA1 & KA2
 TO ENABLE SUPPLIES 6 THRU 9.
 THIS COMMON IS NOT A TRUE NEUTRAL.
 DO NOT CONNECT LOAD BETWEEN LINE 1,
 LINE 2 OR LINE 3 AND THIS COMMON.
 220V BETWEEN ALL LINES AND COMMON.

PHM1931S

Section 4 Troubleshooting

12. EMPTY ALARM ANALYSIS

Symptom: The display reads “EMTYXX,” the buzzer sounds and the signal light is displayed. The computer did not receive an input from the low side of the water level switch telling it that the washer-extractor emptied in the time that had been programmed.

NOTE: If the empty alarm occurs in less than one minute from the point when the drain closed light goes out, check the drain time that has been programmed into this step of the computer. The factory recommends that at least one minute should be provided for each drain step.

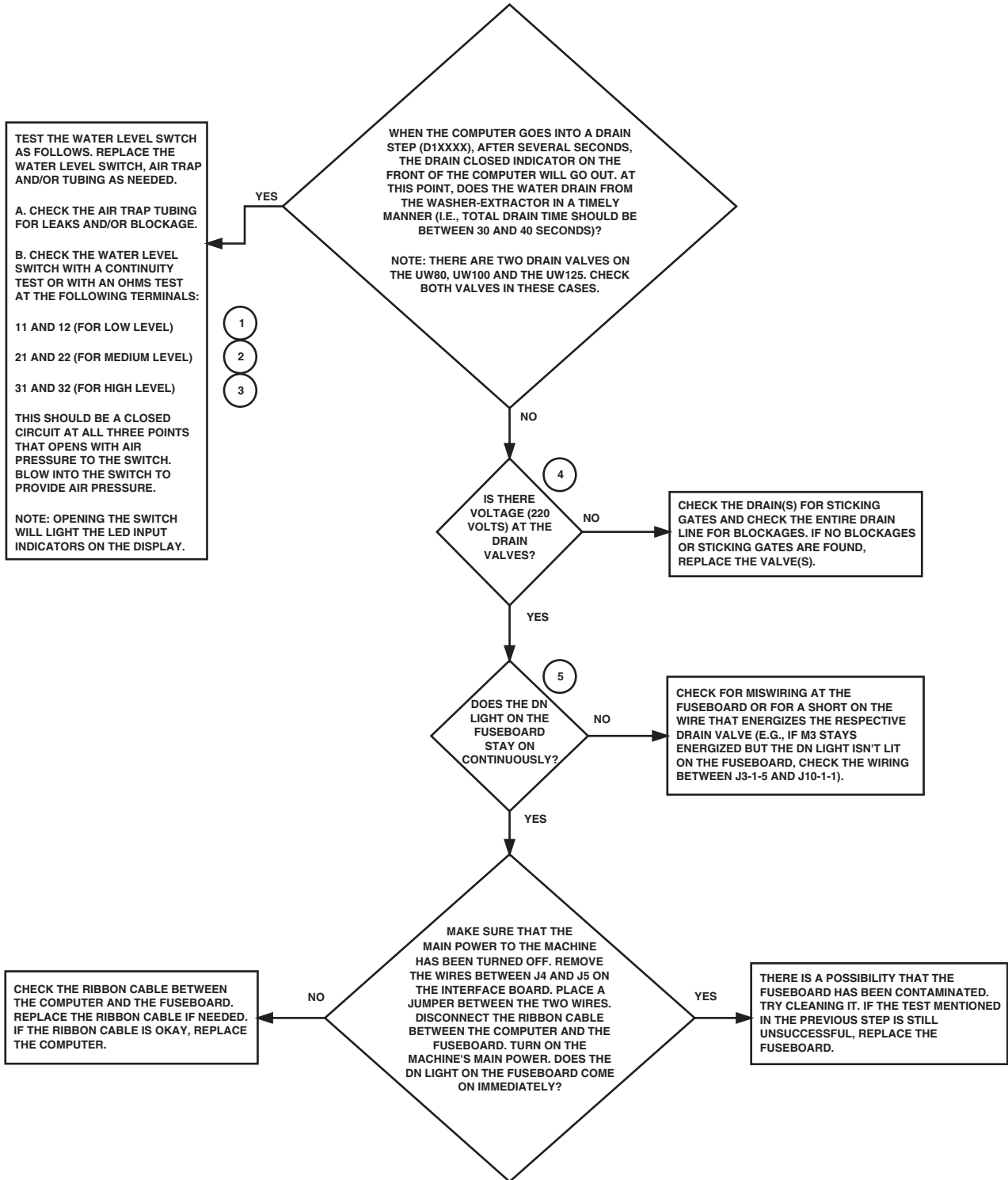

PHM1928S

Please refer to the following 2 pages for wiring diagram information.

Empty Alarm Analysis (Sheet 1 of 2)

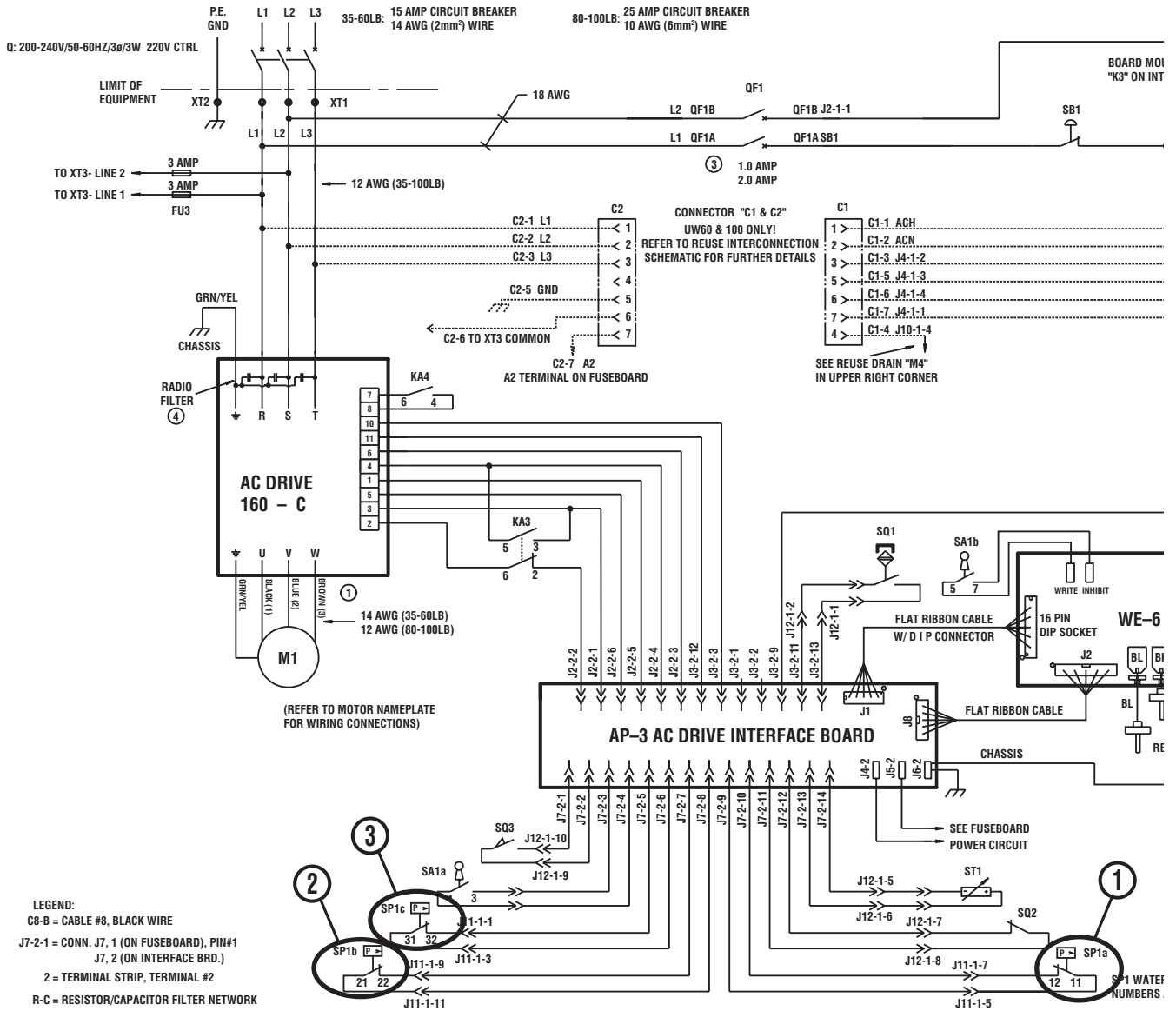

LEGEND:
 C8-B = CABLE #8, BLACK WIRE
 J7-2-1 = CONN. J7, 1 (ON FUSEBOARD), PIN#1
 J7, 2 (ON INTERFACE BRD.)
 2 = TERMINAL STRIP, TERMINAL #2
 R-C = RESISTOR/CAPACITOR FILTER NETWORK
 △ = TERMINAL STRIP JUMPER
 (TERMINAL STRIP JUMPERS MAY BE USED IN VARIOUS PLACES NOT SHOWN ON SCHEMATIC)

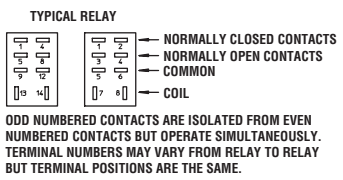

- NOTES:
- 1 THE DRIVE MOTOR (M1) IS DUAL VOLTAGE CAPABLE, REFER TO NAMEPLATE OF MOTOR BEFORE WIRING. IF MOTOR ROTATION IS INCORRECT, SWAP ANY 2 WIRES OF CABLE BETWEEN AC DRIVE AND MOTOR.
 - 2 REFER TO PROGRAMMING MANUAL FOR DETAILED INSTRUCTIONS TO OPERATE SUPPLIES. SUPPLY 5 OUTPUT PROVIDES POWER TO ACTIVATE RELAYS KA1 & KA2 IN ORDER TO ENABLE EXTERNAL SUPPLIES 6 THROUGH 9. EXAMPLE: IF SUPPLY 1 IS PROGRAMMED, THE SUPPLY 1 OUTPUT PROVIDES A 220V SIGNAL TO EXTERNAL SUPPLY 1. WHEN SUPPLY 5 IS PROGRAMMED WITH SUPPLY 1, THE SUPPLY 1 OUTPUT THEN PROVIDES A 220V SIGNAL TO EXTERNAL SUPPLY 6.
 - 3 UW80-100 MACHINES WITH DUAL ELECTRICALLY OPERATED DRAIN VALVES REQUIRE TWO 2 AMP, 250V CONTROL CIRCUIT BREAKERS (QF1). LIKEWISE FOR REUSE DRAIN M4. ALL MACHINES WITH SINGLE ELECTRIC DRAIN VALVES REQUIRE TWO 1 AMP, 250V CONTROL CIRCUIT BREAKERS (QF1).
 - 4 AN ADDITIONAL FILTER (P/N 635654) IS REQUIRED ACROSS THE INPUT OF THE AC DRIVE.

Empty Alarm Analysis (Sheet 2 of 2)

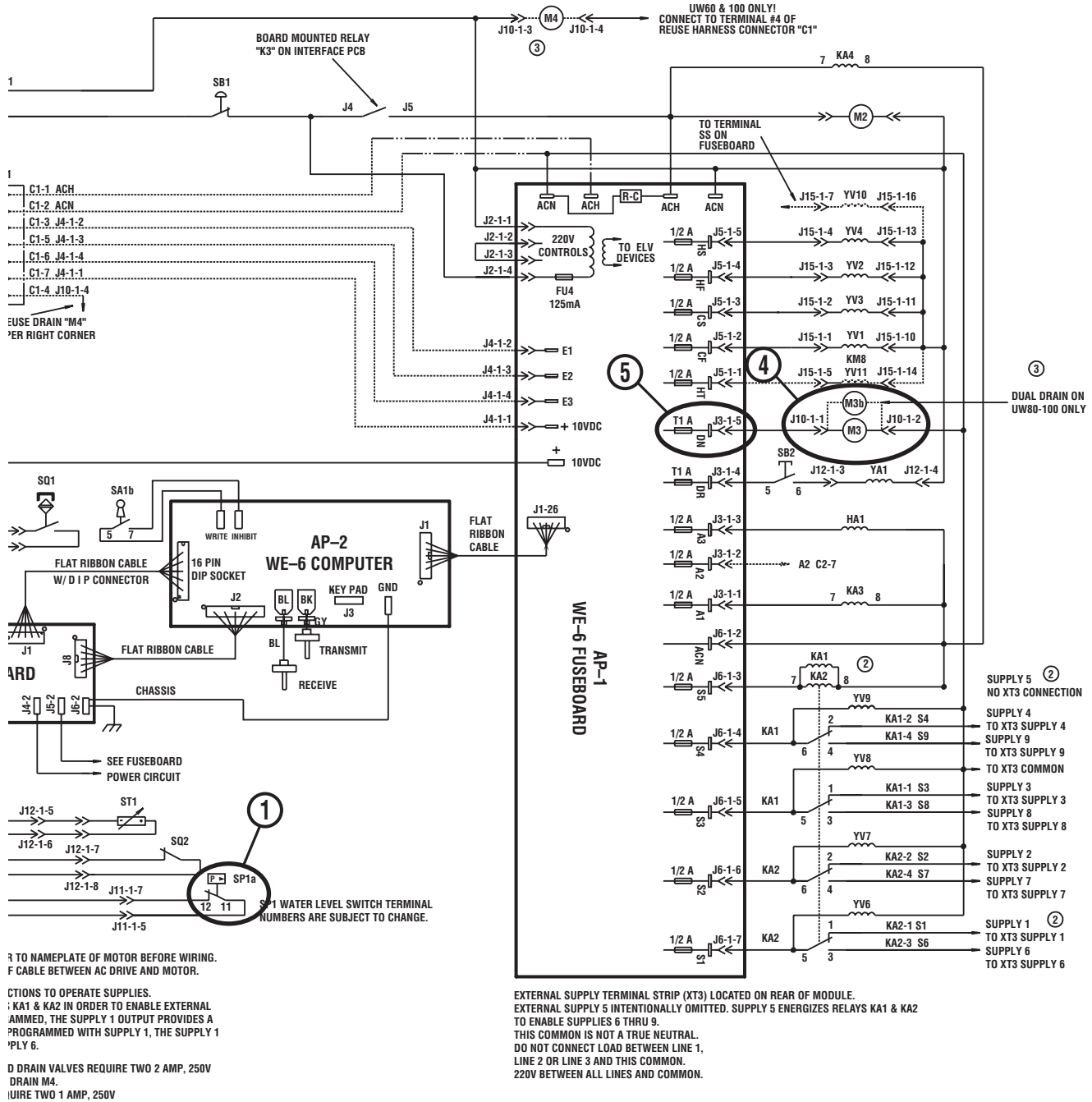

PHM1929S

Section 4 Troubleshooting

13. AUTOMATIC SUPPLY DISPENSER ANALYSIS

Program and run the following steps into any available cycle to test the system.

NOTE: Pre-programmed cycle 39 already has a portion of this cycle pre-programmed into it.

Step	Description	Program	Min:sec
1	Warm Fill to Low Level	Warm Fill	5:00
2	Supply 1	Supply 1	2:00
3	Supply 2	Supply 2	2:00
4	Supply 3	Supply 3	2:00
5	Supply 4	Supply 4	2:00
6	Supply 6	Supply 5 and 1	2:00
7	Supply 7	Supply 5 and 2	2:00
8	Supply 8	Supply 5 and 3	2:00
9	Supply 9	Supply 5 and 4	2:00
10	Wash 1	Wash	:30
11	Drain 1	Drain	1:00

Run the cycle and, with the respective supply on the main display, refer to the following chart for the function that should be occurring:

Supply	Function
1	Flushes Compartment 1
2	Flushes Compartment 2
3	Flushes Compartment 3
4	Flushes Compartments 4 and 5
6	Flushes Compartment 1
7	Flushes Compartment 2
8	Flushes Compartment 3
9	Flushes Compartments 4 and 5

During each step, test for voltage (220 Volts) between each respective supply terminal and the common terminal on the XT3 terminal strip.

NOTE: The XT3 terminal strip is located toward the back of the control module, next to the power input block.

14. NO KEYPAD FUNCTIONS

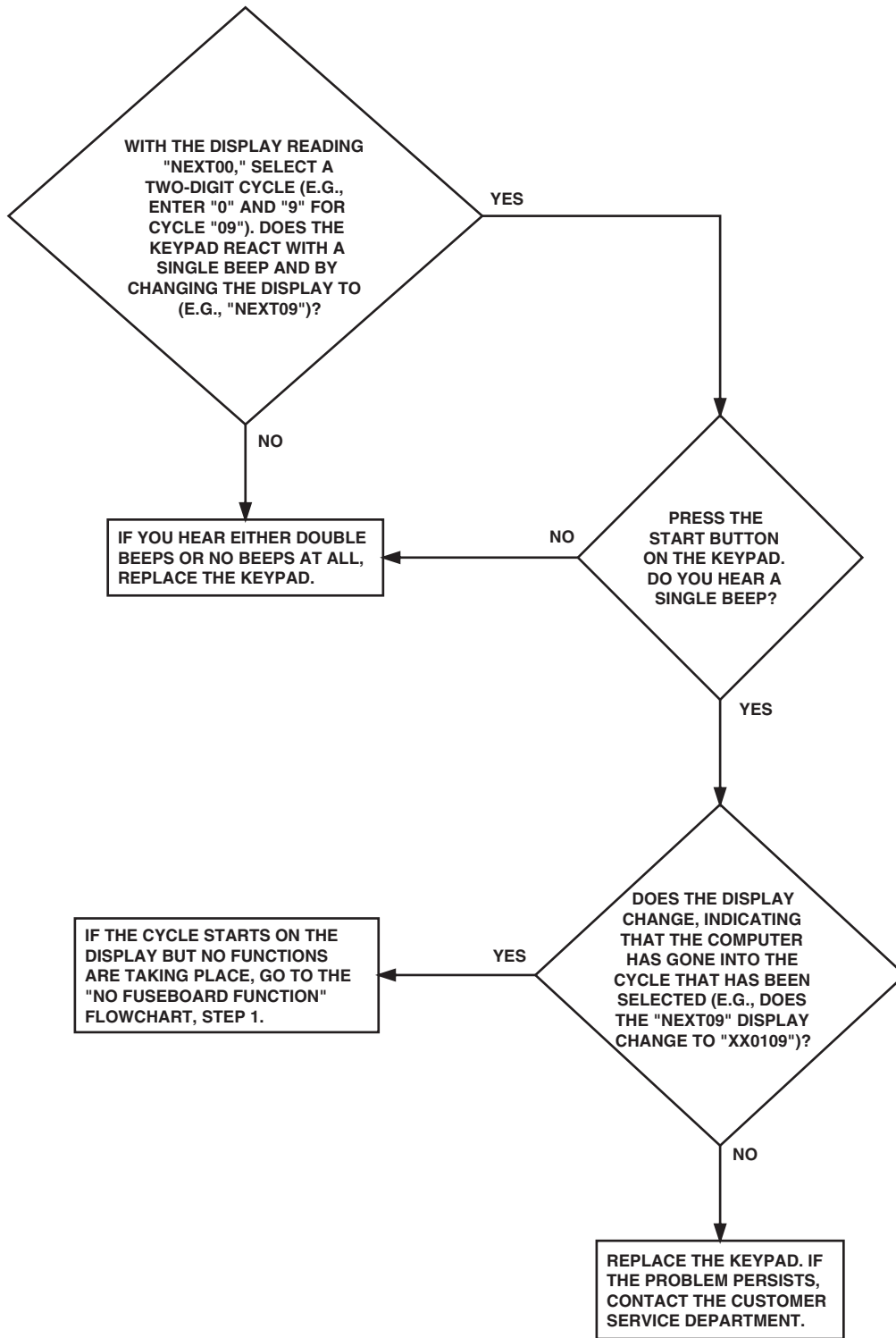

PHM1932S

Section 4 Troubleshooting

15. DOOR UNLOCKING FUNCTION

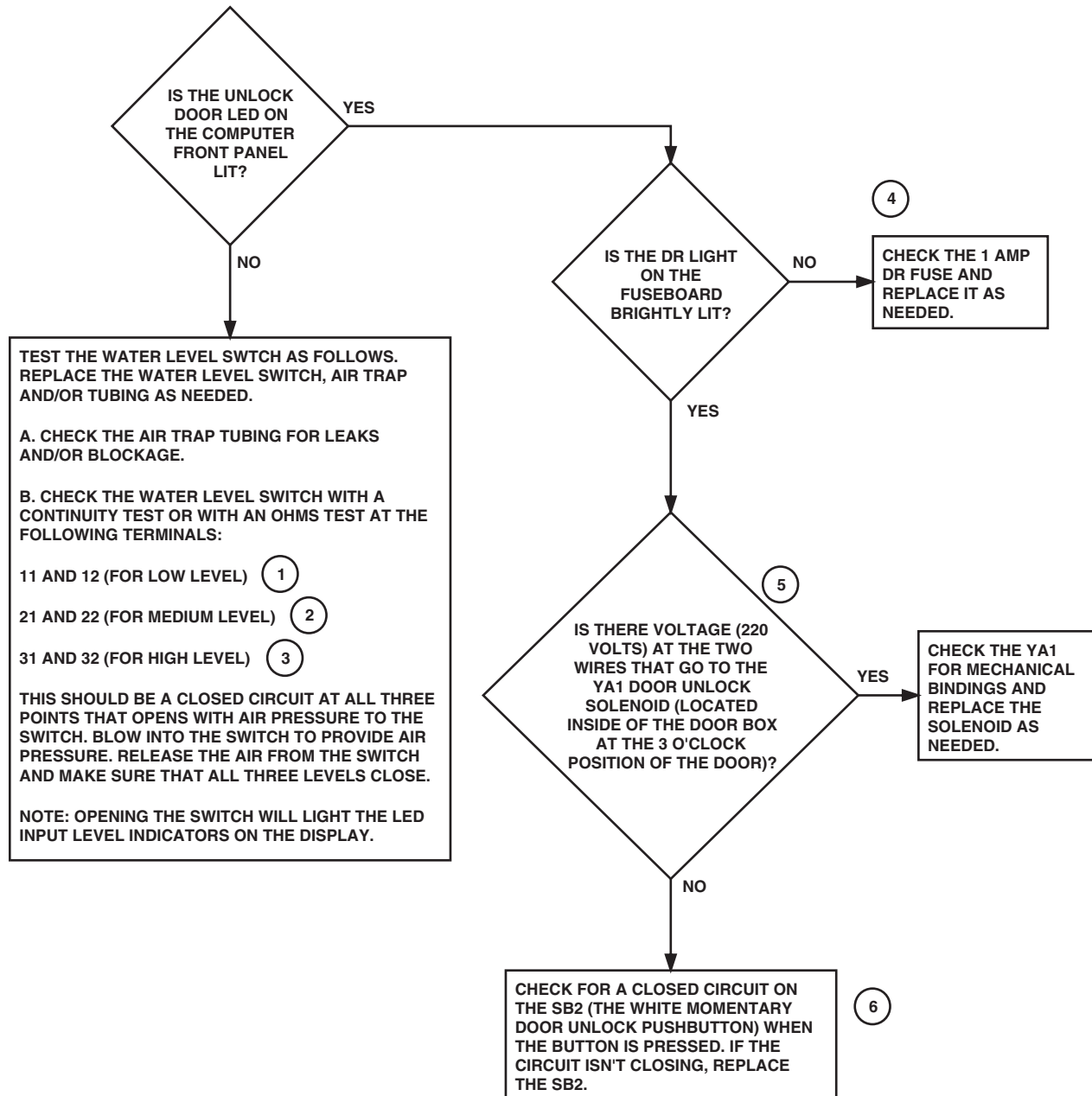

PHM1933S

Please refer to the following 2 pages for wiring diagram information.

Door Unlocking Function (Sheet 1 of 2)

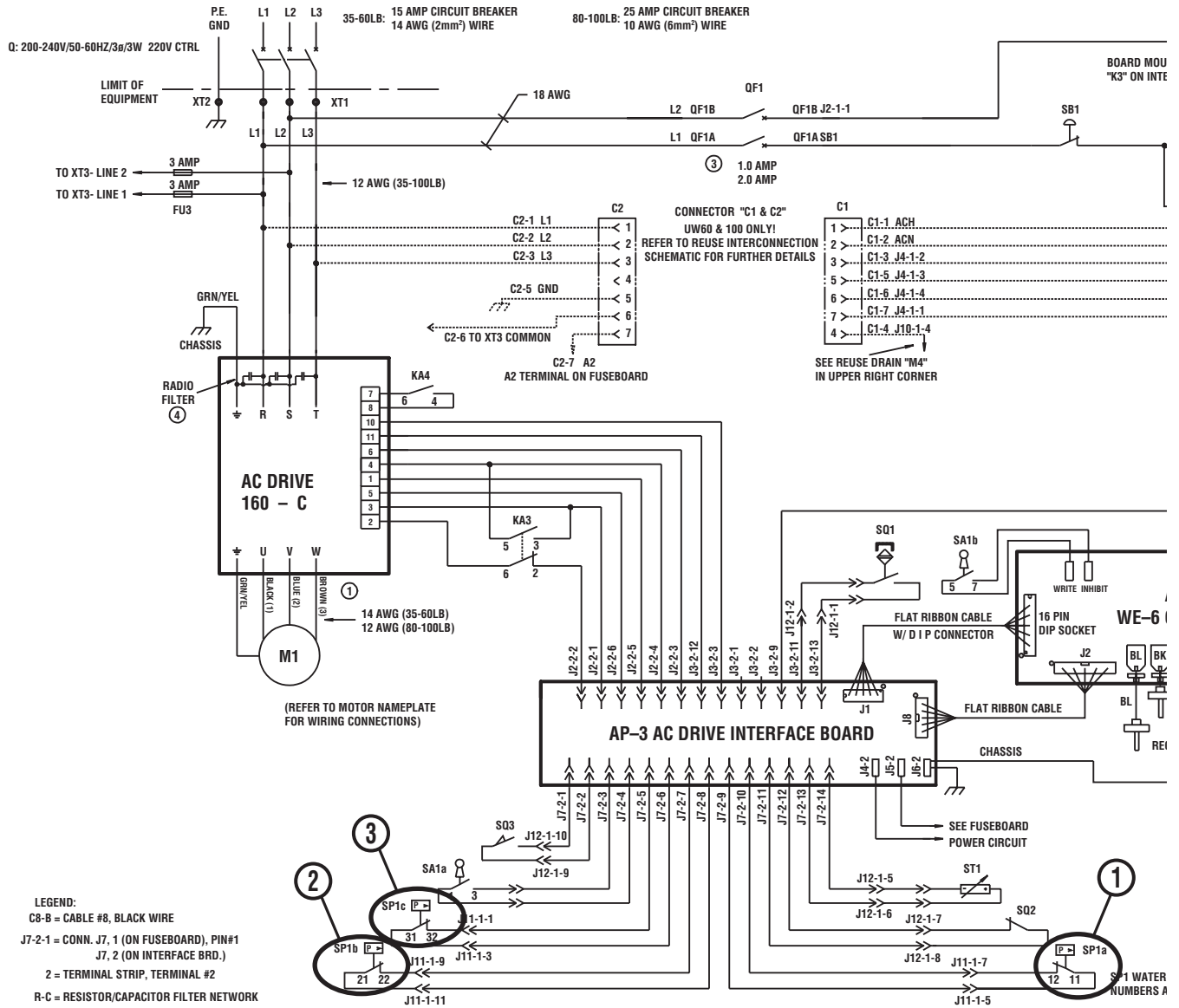

LEGEND:
 C8-B = CABLE #8, BLACK WIRE
 J7-2-1 = CONN. J7, 1 (ON FUSEBOARD), PIN#1
 J7, 2 (ON INTERFACE BRD.)
 2 = TERMINAL STRIP, TERMINAL #2
 R-C = RESISTOR/CAPACITOR FILTER NETWORK
 -△- = TERMINAL STRIP JUMPER
 (TERMINAL STRIP JUMPERS MAY BE USED IN VARIOUS PLACES NOT SHOWN ON SCHEMATIC)

TYPICAL RELAY

ODD NUMBERED CONTACTS ARE ISOLATED FROM EVEN NUMBERED CONTACTS BUT OPERATE SIMULTANEOUSLY. TERMINAL NUMBERS MAY VARY FROM RELAY TO RELAY BUT TERMINAL POSITIONS ARE THE SAME.			

- NOTES:**
- 1 THE DRIVE MOTOR (M1) IS DUAL VOLTAGE CAPABLE, REFER TO NAMEPLATE OF MOTOR BEFORE WIRING. IF MOTOR ROTATION IS INCORRECT, SWAP ANY 2 WIRES OF CABLE BETWEEN AC DRIVE AND MOTOR.
 - 2 REFER TO PROGRAMMING MANUAL FOR DETAILED INSTRUCTIONS TO OPERATE SUPPLIES. SUPPLY 5 OUTPUT PROVIDES POWER TO ACTIVATE RELAYS KA1 & KA2 IN ORDER TO ENABLE EXTERNAL SUPPLIES 6 THROUGH 9. EXAMPLE: IF SUPPLY 1 IS PROGRAMMED, THE SUPPLY 1 OUTPUT PROVIDES A 220V SIGNAL TO EXTERNAL SUPPLY 1. WHEN SUPPLY 5 IS PROGRAMMED WITH SUPPLY 1, THE SUPPLY 1 OUTPUT THEN PROVIDES A 220V SIGNAL TO EXTERNAL SUPPLY 6.
 - 3 UW80-100 MACHINES WITH DUAL ELECTRICALLY OPERATED DRAIN VALVES REQUIRE TWO 2 AMP, 250V CONTROL CIRCUIT BREAKERS (QF1). LIKEWISE FOR REUSE DRAIN M4. ALL MACHINES WITH SINGLE ELECTRIC DRAIN VALVES REQUIRE TWO 1 AMP, 250V CONTROL CIRCUIT BREAKERS (QF1).
 - 4 AN ADDITIONAL FILTER (P/N 635654) IS REQUIRED ACROSS THE INPUT OF THE AC DRIVE.

Door Unlocking Function (Sheet 2 of 2)

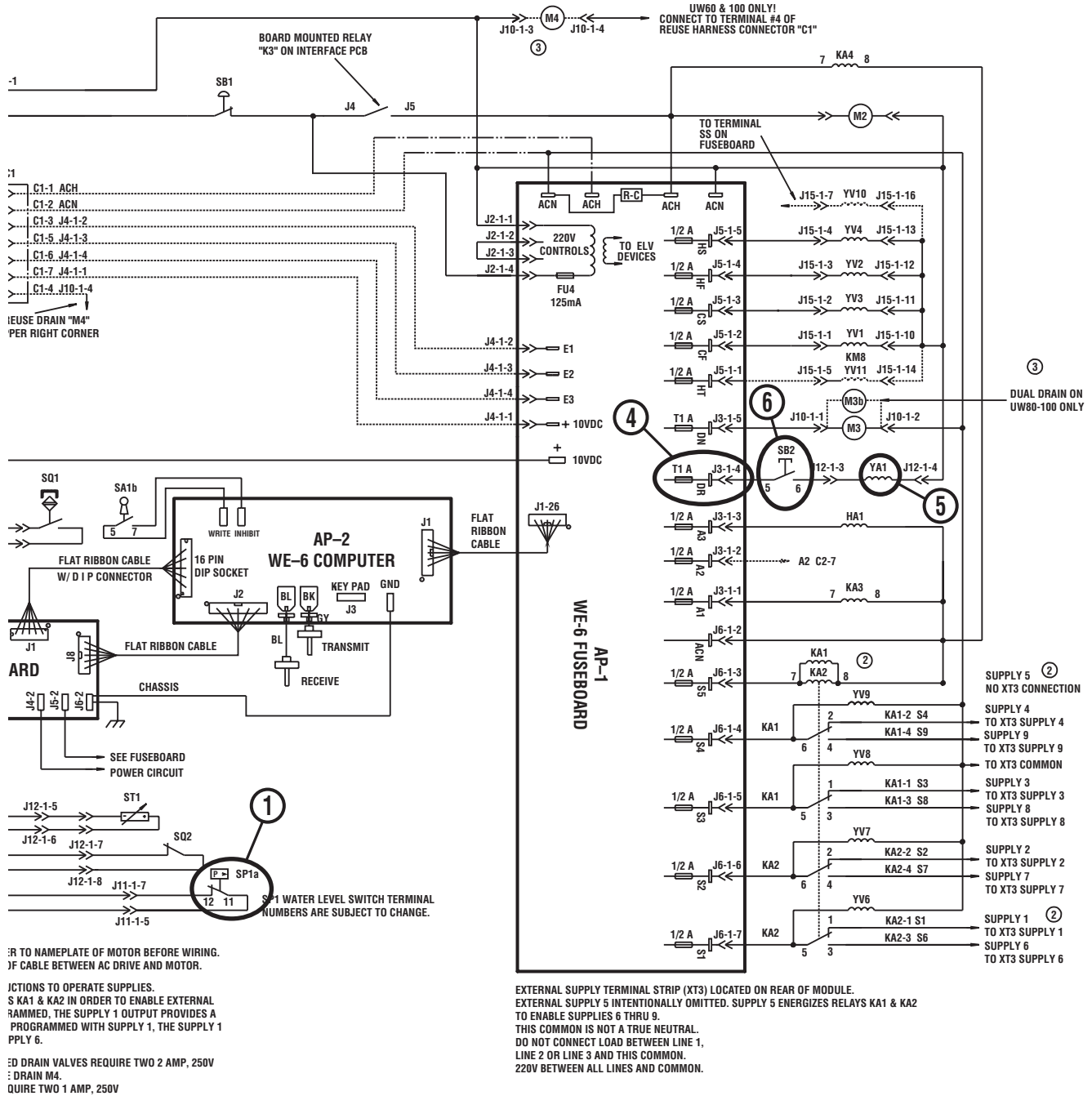

Section 4 Troubleshooting

16. EXCESSIVE CYCLE TIME

When experiencing excessive cycle time, there are three main causes which are as follows:

a. Fill Time:

- (1) Check for excessively long fill times. Refer to the “Fill Alarm Analysis” flowchart if any are found.
- (2) Check for excessively long programmed fill times.

NOTE: All pre-programmed fill times are for 5 minutes. Any fill should easily complete during this time.

b. Drain Time:

- (1) Look for excessively long programmed drain times (i.e., greater than one minute).

NOTE: Any drain step should not exceed 30-40 seconds.

c. Unnecessary Programming Steps:

- (1) E.g., in the first fill of a cycle, if “S102XX” is programmed for 45 seconds and “S203XX” is programmed for 45 seconds, the two steps can be accomplished together at the same time, saving 45 seconds. Refer to the “Programming Multiple Supply Steps” section of your washer-extractor’s programming manual.

17. EXCESSIVE VIBRATION AND/OR NOISE DURING SPIN

When experiencing excessive vibration and/or noise during a spin cycle, there are three main causes, which are as follows:

a. Improper Loading:

- (1) Always make sure that full loads are used. Never wash partial loads.
- (2) Do not mix various laundry items together in the same wash (e.g., do not wash towels and sheets together).

b. Improper Installation:

- (1) Make sure that the washer-extractor is anchored to a flat, level surface with the proper depth of concrete.
- (2) Tighten all anchor bolts and nuts. Make sure that they are of the correct size and grade.
- (3) Make sure that the washer-extractor is grouted properly.
- (4) Refer to your washer-extractor's installation manual for exact installation specifications.

c. Faulty Front and/or Rear Bearings:

- (1) Check the front and rear bearings' noise factor.
- (2) Lift up on the basket at the front of the tub. Check for any up and down play that would indicate bearing wear.
- (3) Replace the bearings as needed.

18. STOP/DONE SITUATION IN MID CYCLE

If the washer-extractor stops in mid-cycle, this indicates that the computer saw an open circuit at the door lock microswitch.

Check the door lock microswitch for loose connections or broken wires. Repair the wires or replace the microswitch as needed.

19. POWER WAIT SITUATION IN MID CYCLE

A power wait situation in mid cycle indicates that the machine's computer lost power.

- a. Check the computer's battery back-up. Replace the battery as needed.
- b. If the battery is okay, check for voltage at the white plug by the transformer on the output board. Voltage present should either be 120 or 220 VAC, depending on the control voltage.

20. PUMPS TURNING ON IN MID CYCLE WITHOUT BEING PROGRAMMED TO DO SO

Pumps turning on in mid-cycle without being programmed to do so may be the result of resistors on the output board allowing low voltage leaks (between 1 and 40 VAC).

Replace the resistors on the output board (that correspond to the pumps that are turning on in mid cycle) as needed.

Section 5

Service Procedures

	WARNING
<p>To reduce the risk of electrical shock, fire, explosion, serious injury or death:</p> <ul style="list-style-type: none"> • Disconnect electrical power to the washer-extractor before servicing it. • Close the gas shut-off valve to the washer-extractor (when applicable) before servicing it. • Never start the washer-extractor with any guards/panels removed. • Whenever ground wires are removed during servicing, these ground wires must be reconnected to ensure that the washer-extractor is properly grounded. 	
<small>W461R1</small>	

	WARNING
<p>To reduce the risk of serious injury, disconnect power and water to the machine before attempting any maintenance, repairs or service or before removing any panels.</p>	

21. VOLTAGE DISTRIBUTION

Incoming electrical service is supplied to the machine via a terminal strip mounted inside of the control module. From the terminal strip, lines L1, L2 and L3 (on 3 phase models) or lines L1 and L2 (on single phase models) are routed directly to the AC drive. The drive is powered up when the machine receives power.

L1 and L2 also go to the primary side of the control voltage transformer on P and N-voltage machines.

P voltage (380-415V/50-60 Hz/3 ϕ /3W) and N-voltage (440-480V/50-60 Hz/3 ϕ /3W) machines have a 0.5 Amp circuit breaker for 150VA TX sizes (single-drain versions) and 1 Amp circuit breaker for 250VA TX sizes (dual-drain machines) on the primary side of the TX. This protects the TX primary and the input wires from overloads. The secondary side of the TX has 1 Amp (on single drain models) or 2 Amp (on dual-drain models) circuit breakers to protect the control circuit and TX from overloads on the secondary side of the TX. An overload or improper TX connection can trip both the primary and/or secondary breakers.

The control voltage transformer outputs are routed to the circuit breakers (QF1A and QF1B). From QF1A, the line goes to SB1 (E-Stop), to the AC Drive interface board and then to the output board. From QF1B, the common goes to the output board connector J2-1-1. All of the neutral (common) wires in the control circuitry are connected together electrically but are not connected to 'ground.' The Q-voltage (200-240V/50-60 Hz/3 ϕ / 3W) and T-voltage (200-240V/50-60 Hz/1 ϕ /2W) machines will have the control voltage

taken directly off of L1 and L2 (R and S). The control voltage will then route through a 1 Amp circuit breaker (the same routing as the secondary from the control transformer as described above), one per line, before progressing to the actual controls. (If the machine is equipped with dual drains, two 2 Amp circuit breakers will be used in place of the 1 Amp version.)

Control transformers should be connected to deliver a maximum of 240 Volt (60 Hertz) or 220 Volt (50 Hertz) secondary voltage. Refer to *Transformer Connection Table* below for all available connection terminals.

(E.g., for 415 Volt/50 Hertz input, connect to H1-H4 primary and X1-X2 secondary.)

Transformer Connection Table		
Primary (Input)		Secondary (Output)
H2-H4	H1-H4	X1-X2
355 Volt	415 Volt	202 Volt
380 Volt	440 Volt	215 Volt
400 Volt	460 Volt	226 Volt
–	480 Volt	235 Volt
–	500 Volt	246 Volt

A ground lug is provided inside of the control module where the electric service is connected. It should be connected to a proven earth ground. This equipment ground is important but does NOT carry normal operating power.

The 220V AC (hot) is routed first through the 1 Amp control circuit breakers. From the control circuit breakers, it is connected through the emergency stop switch and the board mounted relay “K3” (on the AC drive board) before reaching ACH on the fuse board and KA6 door lock safety relay coil that, when energized, will close, allowing the drive to be enabled to run.



WARNING

To reduce the risk of electrical shock, fire, explosion, serious injury or death:

- Disconnect electrical power to the washer-extractor before servicing it.
- Close the gas shut-off valve to the washer-extractor (when applicable) before servicing it.
- Never start the washer-extractor with any guards/panels removed.
- Whenever ground wires are removed during servicing, these ground wires must be reconnected to ensure that the washer-extractor is properly grounded.

W461R1

While the door is open, there will be no AC voltage available to ACH on the fuse board and no outputs will operate.

NOTE: This is a safety circuit. Do not bypass it.

220 Volt AC for the computer is taken immediately after the control circuit breaker and “K3” that is connected to the 4-pin plug at the top center of the fuse board. A 1/8 amp slo blo fuse is located next to the 4-pin plug and protects the computer power supply that is in the center of the fuse board. 12VDC is supplied to the microcomputer board via a 26-conductor ribbon cable.

Each of the 20 outputs on the fuse board is connected to the ACH input through a solid-state current switch

that is controlled by a low-voltage signal from the microcomputer.

The door unlock and the drain outputs are fused with a 1 Amp slo blo fuse. Each of the other 13 outputs are fused with a 1/2 Amp fuse (500MA). All fuses on the fuse board are 5 x 20 mm.

Next to the output tab (a push-on quick connect) for each output is an LED. This LED will be lit whenever the output is ON and the fuse is intact. A lit LED indicates that output voltage is being applied to the output tab. These LEDs will also glow, though at less than normal brightness, if there is not a load (coil) attached to the output or if the path through the load and back to ACN is open. For this reason, fuses are normally removed from any output which does not have a load attached to it.

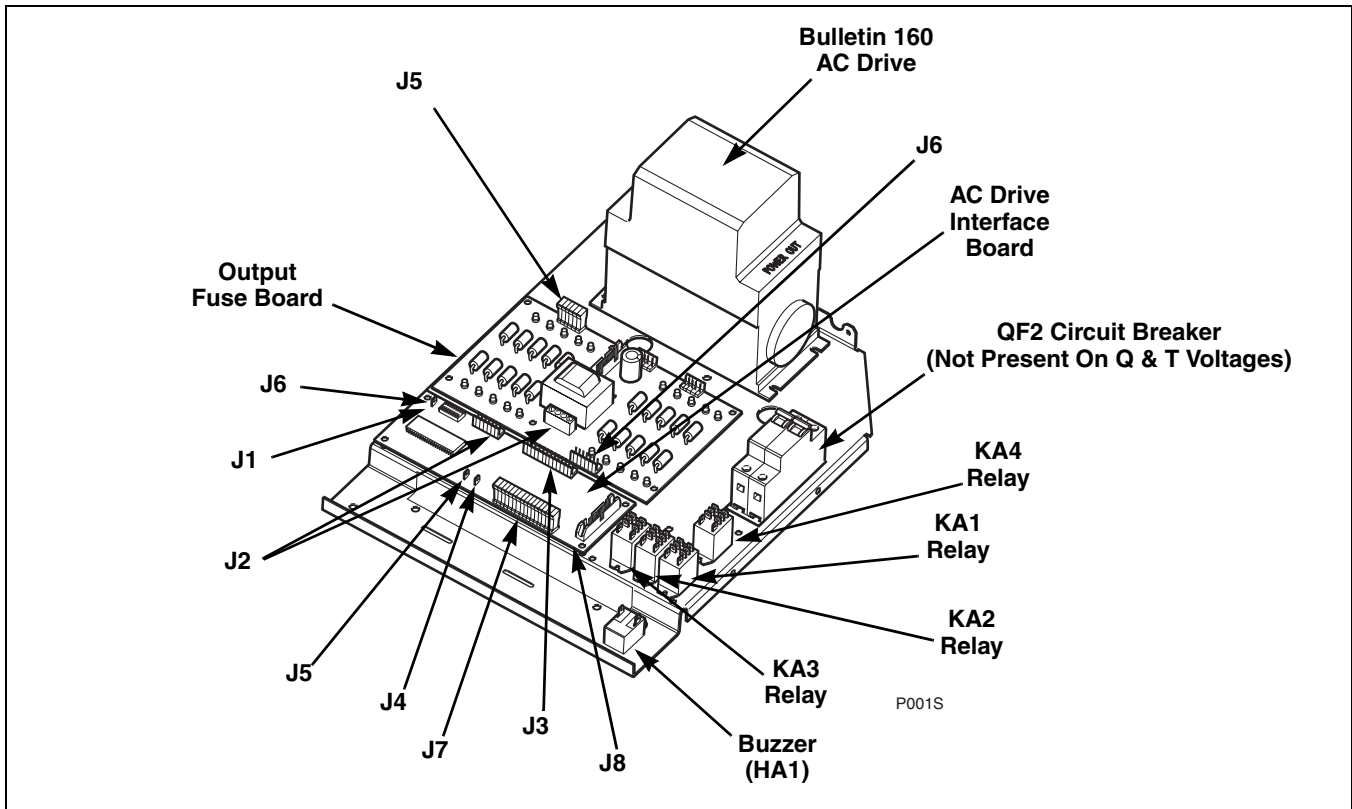



Figure 1
Display/Fuse Board, Interface Board



WARNING

To reduce the risk of electrical shock, fire, explosion, serious injury or death:

- **Disconnect electrical power to the washer-extractor before servicing it.**
- **Close the gas shut-off valve to the washer-extractor (when applicable) before servicing it.**
- **Never start the washer-extractor with any guards/panels removed.**
- **Whenever ground wires are removed during servicing, these ground wires must be reconnected to ensure that the washer-extractor is properly grounded.**

W461R1

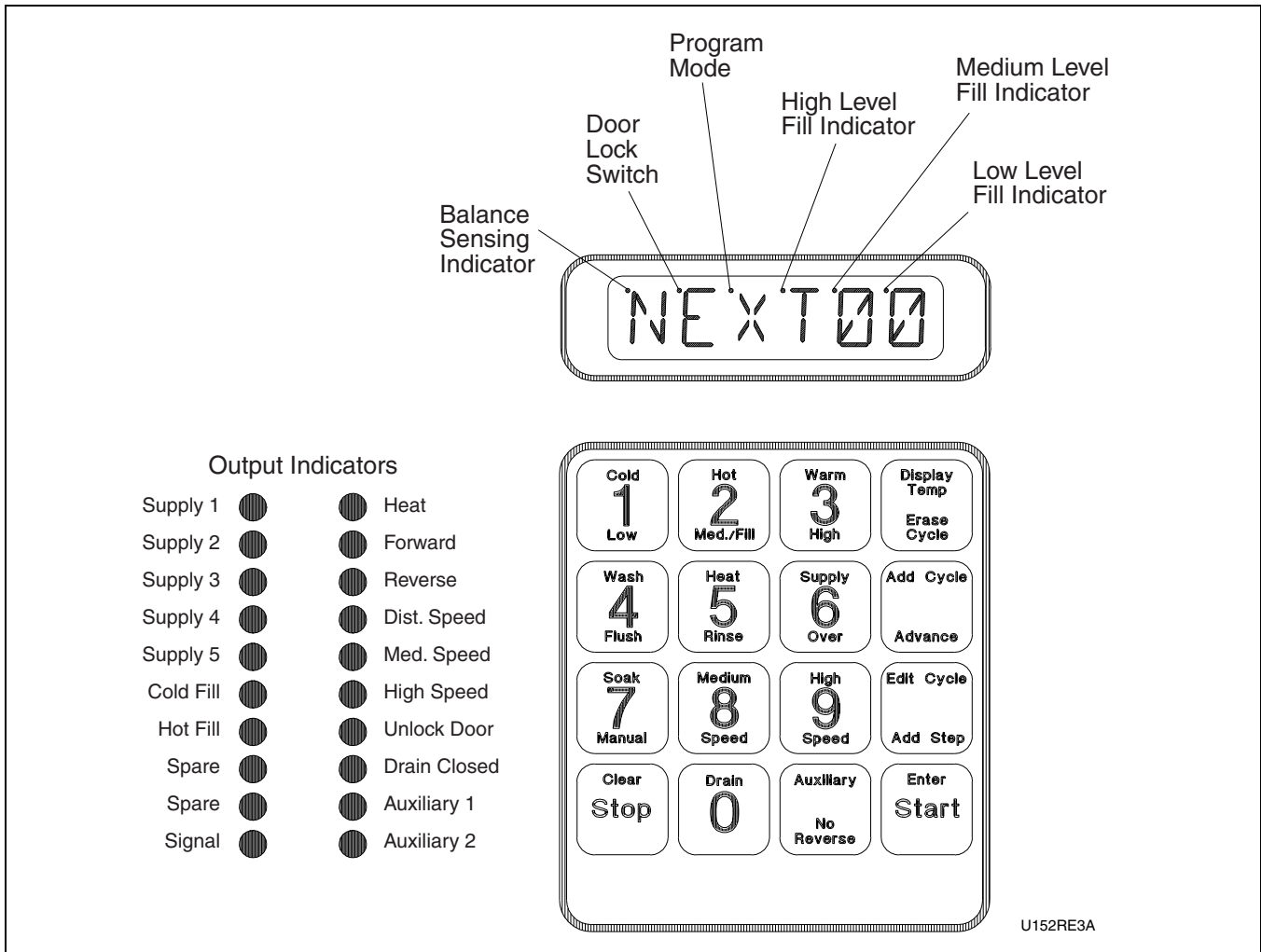



Figure 2
Sample Keypad with LED Indicators

22. ELECTRICAL TESTING

Required equipment for electrical testing includes a digital or analog multimeter and an AC drive parameter unit. The parameter unit is used for troubleshooting, for diagnosing problems between the motor/AC drive and to measure motor current. It is available from Alliance Laundry Systems. Order the specific unit referenced in the parameter listing that came with the machine.

	<h2 style="margin: 0;">WARNING</h2>
<p>To reduce the risk of electrical shock, fire, explosion, serious injury or death:</p> <ul style="list-style-type: none"> • Disconnect electrical power to the washer-extractor before servicing it. • Close the gas shut-off valve to the washer-extractor (when applicable) before servicing it. • Never start the washer-extractor with any guards/panels removed. • Whenever ground wires are removed during servicing, these ground wires must be reconnected to ensure that the washer-extractor is properly grounded. 	
W461R1	

NOTE: Do not attempt to measure motor current with a clip-on Amp meter on UWPV machines. Incorrect readings will result.

The Amp meter can be used to detect excessive electrical current draw that causes overloads on breakers and fuses. The Amp meter clamps around the current-carrying wire. Refer to the instructions furnished with the meter.

The volt/ohm meter will measure volts when set on “volt.” It will measure ohms (resistance) when set on “ohm.” This setting can also be used for continuity testing.

As mentioned in safety warnings, the power to the machine must be disconnected before servicing. Wires should be disconnected from the component or components being checked. Using the ohm meter, test leads are placed in contact with the terminals being checked.

For example:
 To check any switch, set the ohm meter to the “ohm” scale as outlined in the meter’s operating instructions. Place one lead on each terminal. Refer to *Figure 3*. Depress the switch button. If the switch is making contact, the needle on the meter will move towards the “0” end of the ohm scale. This indicates continuity through the switch. When the switch button is released, the needle will move back to its original position. Continuity through wires can be tested in the same manner.

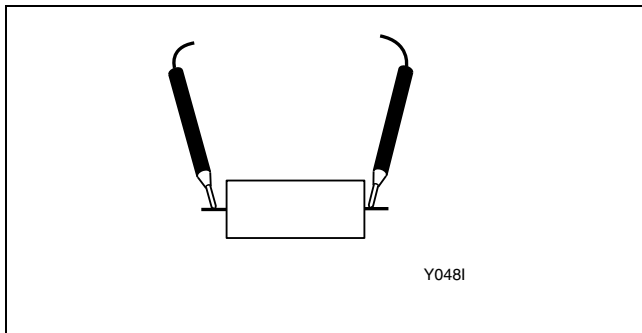





Figure 3
Meter Lead Placement

	<h2 style="margin: 0;">WARNING</h2>
<p>To reduce the risk of bodily injury and/or property damage such as fire, electric shock or equipment damage, washer-extractors must be installed, adjusted and serviced by qualified electrical maintenance personnel familiar with the construction and operation of the type of machinery. These personnel must also be familiar with the potential hazards involved. If this warning is not observed, personal injury or equipment damage (that may result in voiding the warranty) can occur.</p>	

	<h2 style="margin: 0;">WARNING</h2>
<p>To reduce the risk of electrical shock, be sure that a ground wire from a proven earth ground is connected to the chassis ground lug in the electrical junction box on the machine. Without proper grounding, personal injury from electrical shock may occur and machine malfunctions may be evident.</p>	

NOTE: Computer controlled machines must have a proper ground to prevent computer malfunctions.

	<h2 style="margin: 0;">WARNING</h2>
<p>To reduce the risk of injury, replace all panels that have been removed to perform service and maintenance procedures, do not operate the machine with guards removed or with parts missing or broken and do not bypass any safety devices.</p>	

	WARNING
<p>To reduce the risk of electrical shock, fire, explosion, serious injury or death:</p> <ul style="list-style-type: none"> • Disconnect electrical power to the washer-extractor before servicing it. • Close the gas shut-off valve to the washer-extractor (when applicable) before servicing it. • Never start the washer-extractor with any guards/panels removed. • Whenever ground wires are removed during servicing, these ground wires must be reconnected to ensure that the washer-extractor is properly grounded. 	
W461R1	

	DANGER
<p>To reduce the risk of electrical shock, never touch terminals or components of the AC drive unless the power is disconnected and the "CHARGE" indicator LED is off. The AC drive retains potentially deadly voltage for some time after the power is disconnected.</p> <p>Tampering with the AC drive will void the warranty. There are no user-serviceable parts inside of the AC drive.</p>	

	DANGER
<p>To reduce the risk of injury, attempt no entry until the basket has come to a complete stop.</p>	

23. COMPUTER TEST PROCEDURE

	WARNING
<p>Serious shock may occur. Open the primary disconnect switch before attempting any repairs.</p>	

With its fuse board, the WE-6 programmable computer is easier to maintain than other controls. The following procedures should help eliminate problems and determine if components are not functioning properly. Refer to *Figure 2*.

Test equipment required:

- 20K OHM/Volt AC-DC voltmeter.
- Wiring diagram, WE-6 (supplied with the washer-extractor).

Computer Test Procedure

- a. Power up the washer-extractor:
 - (1) When AC power is turned on, the display should flash "POWER"/"WAIT" alternately. After 90 seconds, the display should read "NEXT 00."
 - (2) The door unlock solenoid should function if the door unlock button is pressed.
 - (3) If tests 1 and 2 are positive, go to Step c.
- b. If the computer does not read "NEXT" or does not illuminate, refer to the "WE-6 Control Has No Visible Display" flowchart.
- c. If the computer reads "NEXT":

NOTE: Press the center of the keys, applying only enough pressure to activate them.

- (1) Test the keyboard, first with the keymode switch (located on the left side of the control module) in the "RUN" position. A beep tone should sound as each key is pressed. Press each of the keys except the "START" key and listen for the beep. After pressing all of the keys (except "START"), press "3" and "9," then press "START." The display should flash "NCYC 39" for 3 seconds and then return to "NEXT00."
 - (2) When "DISPLAY TEMP" is pressed and held, the computer display should change to show the temperature inside of the sump. When the key is released, the display should return to the previous read-out.
 - (3) Turn the keymode switch to "PROGRAM" and press "EDIT/CYCLE." The read-out should display "DCYC--."
 - (4) Press "CLEAR/STOP." The display should return to "-CYC 00."
 - (5) Return the keymode switch to the "RUN" position.
- d. If the keyboard does not function as above:
 - (1) Check the plug (J-3) at the bottom center of computer board for proper installation. Refer to *Figure 4*.
 - (2) If the plug is intact and is installed correctly, proceed to *Paragraph 25*.



WARNING

To reduce the risk of electrical shock, fire, explosion, serious injury or death:

- **Disconnect electrical power to the washer-extractor before servicing it.**
- **Close the gas shut-off valve to the washer-extractor (when applicable) before servicing it.**
- **Never start the washer-extractor with any guards/panels removed.**
- **Whenever ground wires are removed during servicing, these ground wires must be reconnected to ensure that the washer-extractor is properly grounded.**

W461R1

24. TEST CYCLE

Cycle 01 is a pre-programmed test cycle used to check all functions of the machine. Refer to *Figure 2*.

- a. Start this cycle by pressing “0,” then “1,” then “START.”
- b. The display should show “CL01” with the LED for “COLD FILL” and “COLD SPRAY” illuminated at the left of the module front, indicating that these water valves have been turned on.
- c. The “DRAIN CLOSED” LED should be lit. The “FORWARD” and “REVERSE” LEDs should alternate on and off.
- d. The programming manual indicates which LEDs should be lit for each step.
- e. If only one LED on the fuse board is not lit:
 - (1) Check the fuse on the fuse board associated with that LED.
 - (2) If the fuse is OK, check the J-1 ribbon cable between the computer and the fuse board.
 - (3) If the fuse is blown, check the related valve or relay for a shorted condition before replacing the fuse.
 - (4) Use a similar procedure for any individual function that does not work.

IMPORTANT: For proper protection when replacing fuses, use replacement fuses with the same type and rating.

If the display indicates a “DOOR” alarm:

- a. The computer has detected an unlocked door.
- b. Check the switch activator on the door lock extension arm.
- c. Check the door lock switch.
- d. Check the input plug, J-2, on the computer board. Refer to *Figure 1*.
- e. Check for loose wires or bad connections associated with the door lock switch.

If the display indicates a “WATER” alarm:

- a. This display will usually appear following a final spin step. This indicates that the computer has not received a signal indicating that the machine is empty. This means that the machine may still contain water. The door remains locked and keyboard will not respond. Check the drain and for a faulty low level switch.

If the display indicates a “FILL” alarm:

- a. The water level was not reached in the allotted time.
- b. Push “START” to add more time to the cycle.
- c. Check for leaks in the air system between the level switches and the water level air chamber.
- d. Check for obstructions in the water level air chamber or tubing.
- e. Check for obstructions or low pressure in the water supply system.
- f. Check for a failed drain valve motor. Check for leaks in the drain valve.
- g. Check for a defective water level switch.

If the display indicates an “EMPTY” (empty) alarm:

- a. The water level has not reached empty in the allotted time.
- b. Check for a slow drain.
- c. Check for a defective water level switch.
- d. Check for obstructions between the air system and the pressure switch.
- e. Check for loose connections in the water level circuit.

NOTE: Sufficient time for filling and draining must be allowed when programming the computer. If a “FILL” or “EMPTY” alarm occurs in only one program, edit that program and re-enter it into the computer, making sure that enough time has been allowed for fill and/or drain.



WARNING

To reduce the risk of electrical shock, fire, explosion, serious injury or death:

- Disconnect electrical power to the washer-extractor before servicing it.
- Close the gas shut-off valve to the washer-extractor (when applicable) before servicing it.
- Never start the washer-extractor with any guards/panels removed.
- Whenever ground wires are removed during servicing, these ground wires must be reconnected to ensure that the washer-extractor is properly grounded.

W461R1

If there is no spin, but the rest of the program is OK:

- a. When a medium or high-speed spin is programmed, the computer looks for an out-of-balance condition and an empty condition.
- b. Check the input plug (J-2) on computer board. Refer to *Figure 5*.
- c. Check the balance switch that is located inside of the frame.
- d. Check the water pressure switch and the drain line. Refer to *Figure 1*.

NOTE: When an “OUT-OF-BALANCE” condition is detected, the computer will automatically reduce the cylinder speed to the “WASH” forward speed to allow the load to redistribute. The computer will look for and attempt to correct the “OUT-OF-BALANCE” three times in each spin step. If the balance condition is still not corrected, the computer will end the cycle.

If the basket goes into spin with water left in the basket:

- a. Check for leaks between the pressure system and the water level switch.

If the display indicates “OVERHT”:

- a. The temperature probe is short-circuited or has an open circuit.
- b. The machine will not perform a heat step until this problem is resolved.
- c. Replace the temperature probe in the sump and recalibrate the temperature circuit. Refer to *Paragraph 30*.

If the display indicates a “TEMP” alarm:

- a. If this alarm is displayed, the temperature sensor has recognized an over temperature limit condition.
- b. Adjust the water temperature as needed.

If the display indicates a “MEMR” alarm:

- a. If this alarm is displayed, the computer has detected a problem with the cycle information.
- b. Review the cycle information and change it as needed.

25. KEYPAD REMOVAL AND INSTALLATION

Removal

- a. Turn off power to the machine.
- b. Remove the two screws at the top rear edge of the module top cover and slide the cover back slightly until it can be removed. Remove the module top cover.
- c. Remove the nut that attaches the metal computer board cover and remove the cover.
- d. Follow the keypad ribbon cable from the keypad to the computer board that is inside of the control module.
- e. Unplug the connector at J-3 (located on the bottom center of the computer board). Refer to *Figure 4*.
- f. Remove the four nuts at the corners of the computer board. Carefully move the computer board away from the front while sliding the keypad ribbon through the slot in the module front.
- g. Carefully remove the old keypad from the control module front. The keypad is self-adhesive and separate from the control module decal.
- h. Remove any residual adhesive from the module front.

NOTE: The module front surface must be clean and smooth before a new keypad is applied. An uneven surface will cause keypad malfunctions.

Installation

- a. Insert the keypad’s plug and ribbon cable through the slot in the module front.
- b. Remove the backing paper from the new keypad.
- c. Align the keypad so that the cable is centered in the slot. Press the keypad into place.
- d. Carefully connect the ribbon cable plug to J-3 at the bottom center of the computer board. Refer to *Figure 4*. The cable must not be twisted and the plug must be centered in the receptacle.
- e. Reinstall the computer board and carefully tighten the four nuts.



WARNING

To reduce the risk of electrical shock, fire, explosion, serious injury or death:

- Disconnect electrical power to the washer-extractor before servicing it.
- Close the gas shut-off valve to the washer-extractor (when applicable) before servicing it.
- Never start the washer-extractor with any guards/panels removed.
- Whenever ground wires are removed during servicing, these ground wires must be reconnected to ensure that the washer-extractor is properly grounded.

W461R1

- f. Reinstall the computer board cover with the nut.
- g. Turn the power on and test the keypad operation. Refer to *Paragraph 23*.

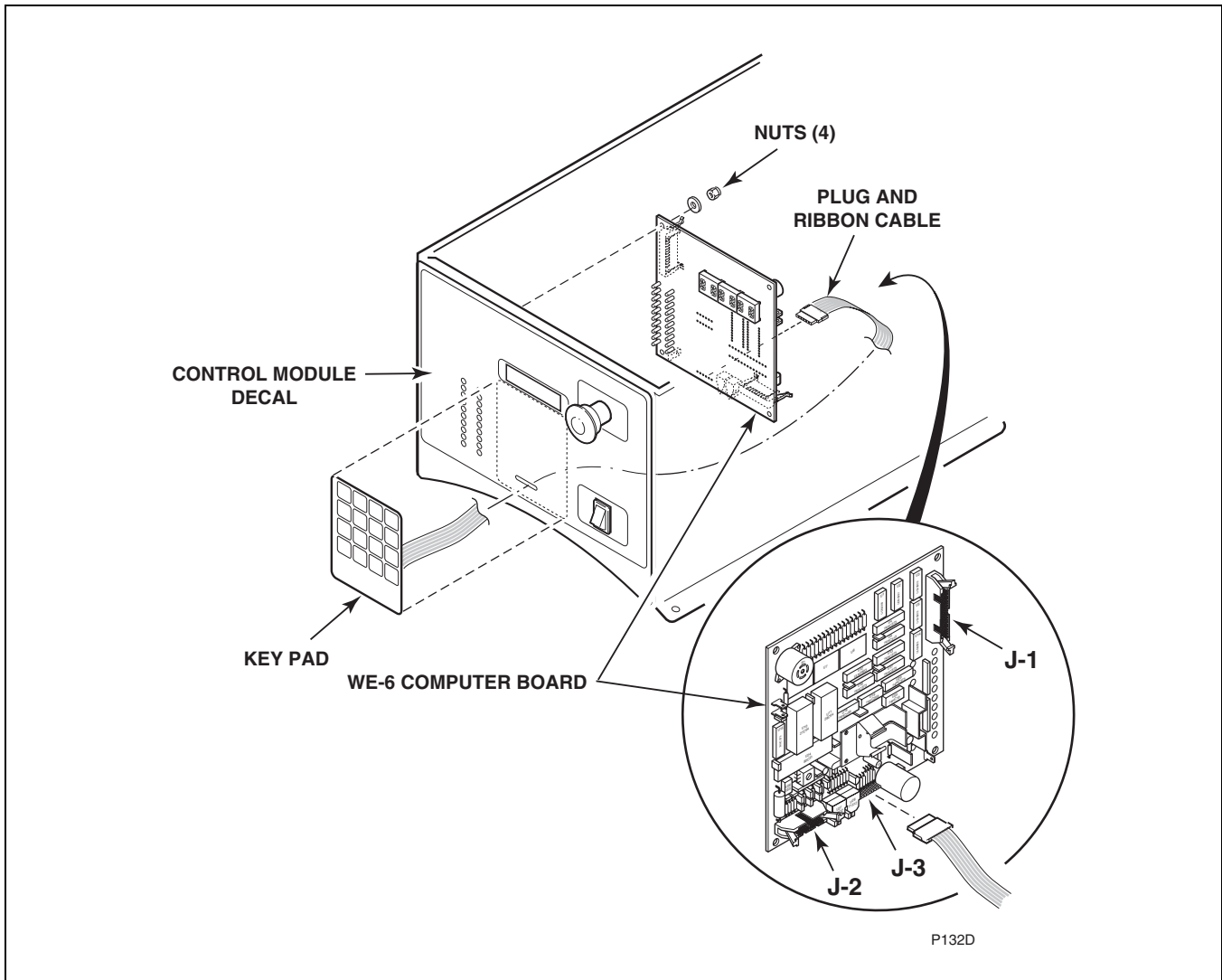

Figure 4
Computer Board and Keypad

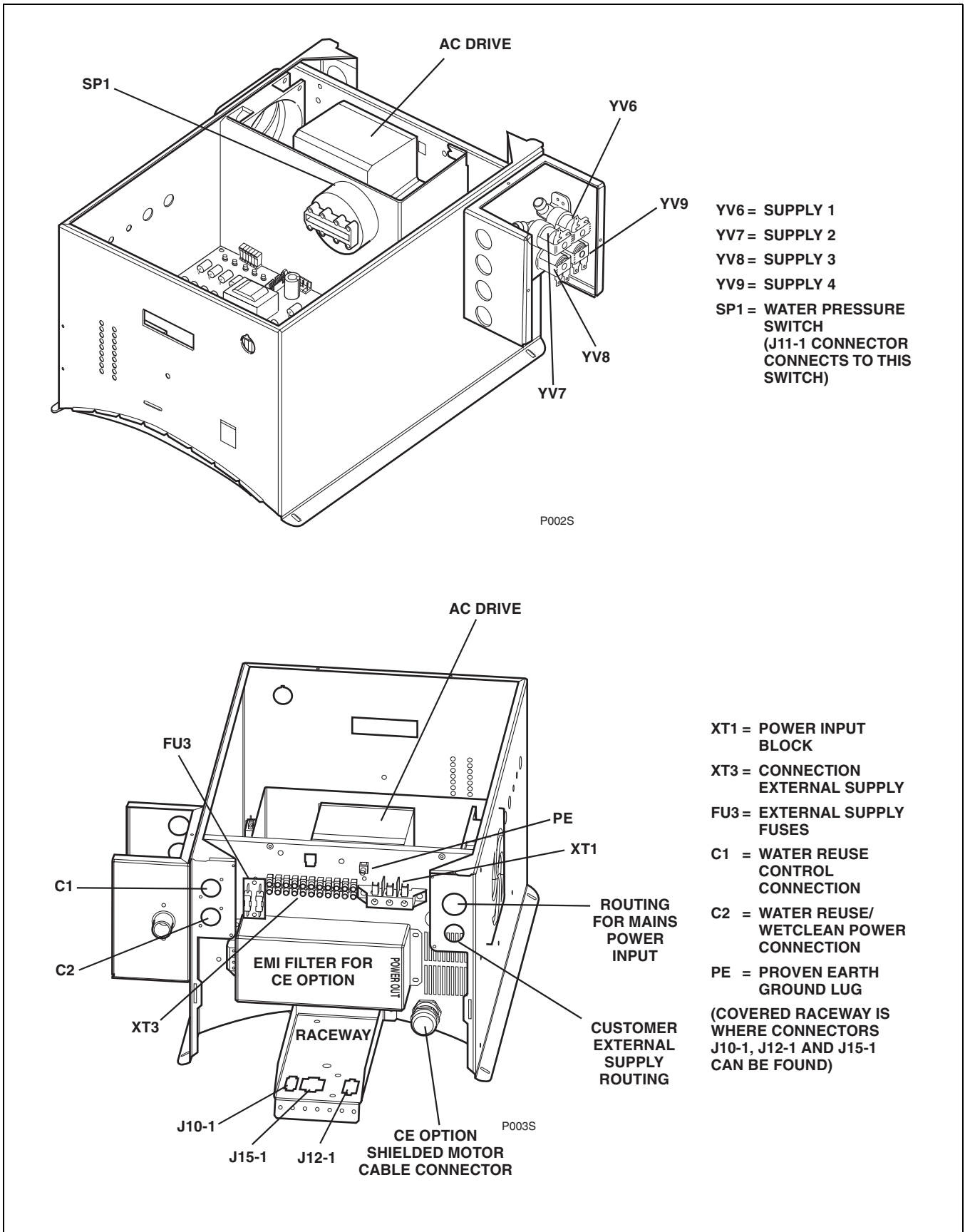

Figure 5
Control Module Familiarization Guide



WARNING

To reduce the risk of electrical shock, fire, explosion, serious injury or death:

- Disconnect electrical power to the washer-extractor before servicing it.
- Close the gas shut-off valve to the washer-extractor (when applicable) before servicing it.
- Never start the washer-extractor with any guards/panels removed.
- Whenever ground wires are removed during servicing, these ground wires must be reconnected to ensure that the washer-extractor is properly grounded.

W461R1

26. COMPUTER BOARD REMOVAL AND INSTALLATION

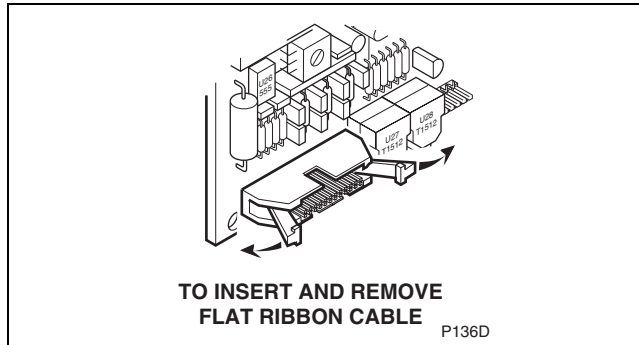

Figure 6

Ribbon Cable Disconnect

Note how the wiring is routed before removing any components and follow the original routing during reinstallation.

- a. Turn off power to the machine.
- b. Remove the two screws at the top rear edge of the module top cover and slide the cover back slightly until it can be removed. Remove the module top cover.
- c. Remove the nut attaching the metal cover that covers the computer board and remove the cover.
- d. Carefully disconnect the 16-conductor ribbon cable plug near the battery at J3, refer to *Figure 4*. Note the position of the red stripe to properly reinstall the cable. Use care when reconnecting this plug to avoid bending pins. Make sure that the pins are aligned with the sockets in the board before carefully seating the plug into the socket.
- e. Disconnect the 26-conductor ribbon cable connector at J1 by pushing on the “ears,” refer to *Figure 6*.
- f. Disconnect the remaining 16-conductor ribbon cable connector at J2 (refer to *Figure 4*) by pushing on the “ears.” Refer to *Figure 6*.
- g. Label and disconnect the two wires from the keymode switch to the computer board at the terminals marked “write inhibit.”

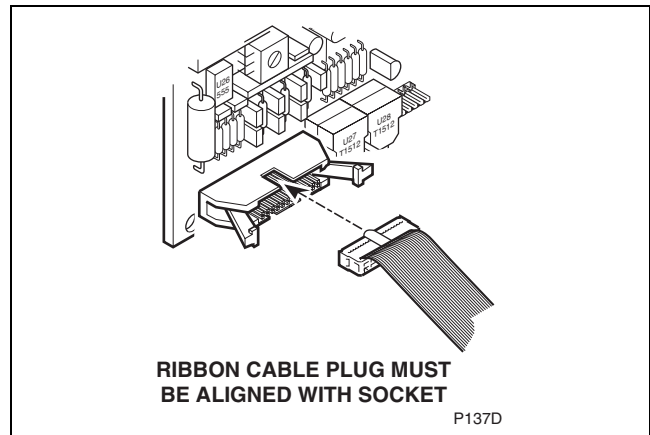

Figure 7

Aligning Plugs and Connecting

- h. Label and disconnect the ground connection at the terminal marked “GND.”
- i. Remove the four nuts at the computer board corners and move the board far enough away from its mounting position to unplug and remove the fiber optic cables at the bottom of the board. Remove the board.
- j. Board installation is the reverse of removal. Carefully align the plugs with the receptacles and push them gently into place. Refer to *Figure 7*.

NOTE: Never force a plug into a receptacle. This can result in damage to the controls.

27. FUSE BOARD REMOVAL AND INSTALLATION

Note how the wiring is routed before removing any components and follow the original routing during reinstallation.

- a. Turn off power to the machine.
- b. Remove the two screws at the top rear edge of the module cover and slide the cover back slightly until it can be removed. Remove the module top cover.
- c. Remove the two clear covers from the board. Refer to *Figure 8*.



WARNING

To reduce the risk of electrical shock, fire, explosion, serious injury or death:

- Disconnect electrical power to the washer-extractor before servicing it.
- Close the gas shut-off valve to the washer-extractor (when applicable) before servicing it.
- Never start the washer-extractor with any guards/panels removed.
- Whenever ground wires are removed during servicing, these ground wires must be reconnected to ensure that the washer-extractor is properly grounded.

W461R1

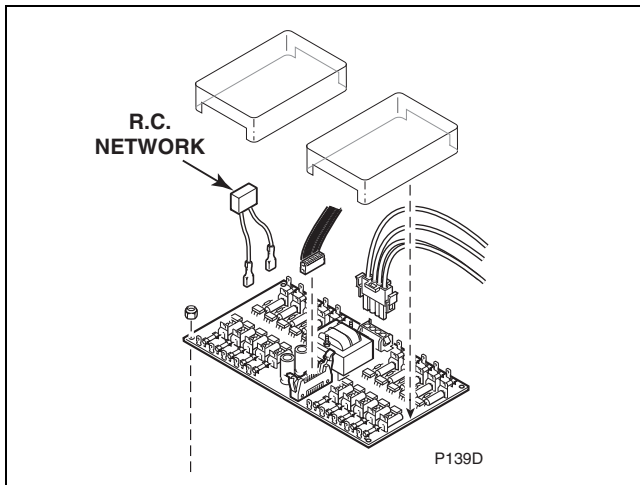

Figure 8
Clear Covers and R.C. Network

- d. Disconnect the 26-conductor ribbon cable at the center of the board (adjacent to the transformer) by pushing on the “ears.” Refer to *Figure 6*.

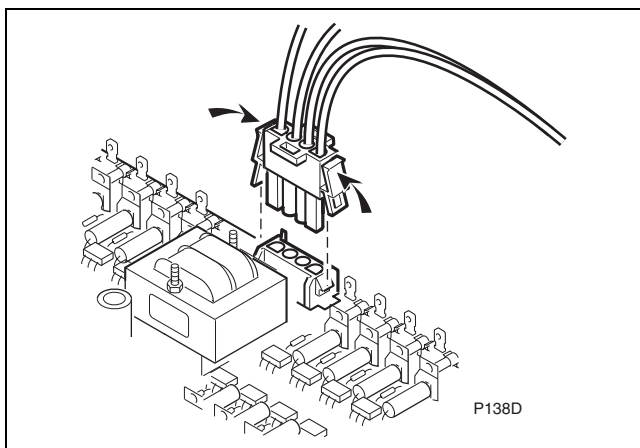

Figure 9
Four-Pin Connector

- e. Unplug the “ACH” and “ACN” connectors.
f. Unplug the four-pin connector by grasping and squeezing the sides. Refer to *Figure 9*.
g. Label the wires and disconnect the headers J6 and J5 from the output board. Refer to *Figure 1*.

- h. Remove the output board from the nylon standoffs (that fasten the board to the module) and remove the board.
i. Board installation is the reverse of removal. Carefully align the plugs with the receptacles and push them gently into place. Refer to *Figure 7*.

NOTE: If the board is being replaced, remove the R.C. network for installation of the new board. Refer to *Figure 8*. Some R.C. networks are not removable. In these cases, the replacement board will include a new R.C. network.

28. INTERFACE BOARD REMOVAL AND INSTALLATION

Note how the wiring is routed before removing any components and follow the original routing during reinstallation.

- a. Turn off power to the machine.
- b. Remove the two screws at the top rear edge of the module top cover and slide the cover back slightly until it can be removed. Remove the module top cover.
- c. Label the headers and remove them from the interface board, refer to *Figure 10*.
- d. Disconnect the 16-conductor ribbon cable plug at J8 (refer to *Figure 10*) by pushing on the “ears.” Refer to *Figure 6*.
- e. Label and disconnect the ground wire at J6. Refer to *Figure 10*.
- f. Carefully disconnect the 16-conductor ribbon cable plug from J1. Refer to *Figure 10*. Note the notch on the socket of the ribbon cable. During installation use this notch as a reference to connect this plug correctly.

NOTE: Extreme care must be used when reconnecting this plug to avoid bending pins. Make sure the pins are aligned with the sockets in the board before carefully seating the plug into the socket.



WARNING

To reduce the risk of electrical shock, fire, explosion, serious injury or death:

- Disconnect electrical power to the washer-extractor before servicing it.
- Close the gas shut-off valve to the washer-extractor (when applicable) before servicing it.
- Never start the washer-extractor with any guards/panels removed.
- Whenever ground wires are removed during servicing, these ground wires must be reconnected to ensure that the washer-extractor is properly grounded.

W461R1

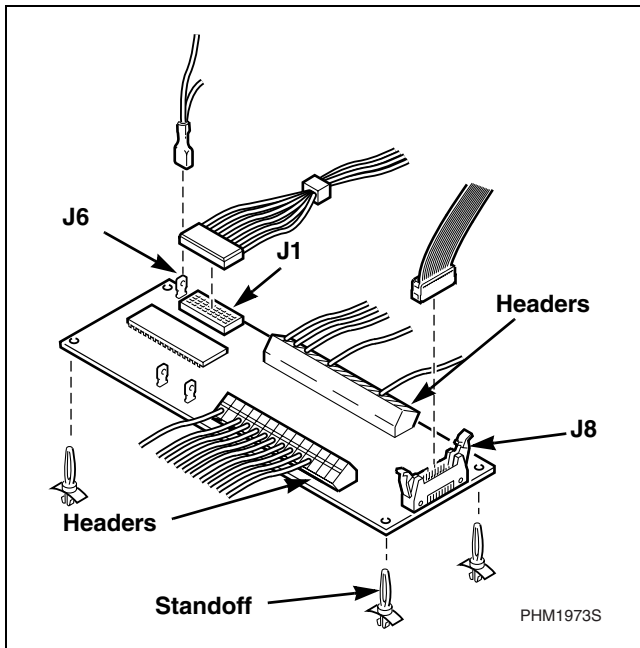

Figure 10
Interface Board

NOTE: In the event of an incorrect ribbon cable connection (i.e., the plug is put on in reverse), the display would be blank. Use care to ensure that the ribbon cable is connected properly.

- g. Remove the AC drive board from the nylon standoffs that fasten the board to the module. Refer to *Figure 9*, and remove the board.
- h. Installation is the reverse of removal.

NOTE: The 16-conductor ribbon cable plug is not polarized so it is possible to insert it backwards. Use the procedure detailed in Step 6 to ensure a correct connection.

NOTE: Never force a plug into a jack. This can result in irreparable damage to the electronic circuitry.

29. KEYMODE SWITCH

Symptoms of a damaged keymode switch may include the following. If the following symptoms occur, replace the keymode switch (refer to the machine's parts manual for keymode switch part numbers).

- a. The computer display doesn't change from "NEXT" to CYC."
- b. The computer allows programming steps to be entered, but the program isn't saved when the keymode switch is turned back to "RUN."

30. CALIBRATING THE WE-6 TEMPERATURE CIRCUIT

- a. Turn off power to the machine.
- b. Remove the two screws at the top rear edge of the module top cover and slide the cover back slightly until it can be removed. Remove the module top cover.
- c. Remove the nut that attaches the computer board cover and remove the cover.
- d. Looking at the lower left of the computer board from the rear of the washer-extractor, find the 1/2 inch x 1/2 inch (13 mm x 13 mm) square blue component with a white plastic screw head in its center. This is the temperature calibration potentiometer. Turning the screw head adjusts the temperature reading. Refer to *Figure 11*.
- e. To allow time for calibration, program the following sequence (refer to the machine's programming manual):
 - (1) Wash 3 for 10 seconds.
 - (2) Cold fill to high level.
 - (3) Wash 3 for 9 minutes, 99 seconds.
- f. Place a thermocouple of the appropriate range inside of the basket well below the high water level.* (See boxed note below if a thermocouple is not available.) Close the door.



WARNING

To reduce the risk of electrical shock, fire, explosion, serious injury or death:

- Disconnect electrical power to the washer-extractor before servicing it.
- Close the gas shut-off valve to the washer-extractor (when applicable) before servicing it.
- Never start the washer-extractor with any guards/panels removed.
- Whenever ground wires are removed during servicing, these ground wires must be reconnected to ensure that the washer-extractor is properly grounded.

W461R1

* As an alternative, if you cannot put the external sensor in the machine as described, take a sample of the fill water entering the machine and record the temperature using an accurate sensor. Then fill the machine using the same fill source and follow Step g.

- g. Start the cycle and, when the high water level is reached (and the external temperature sensor is submerged), press the “Display Temperature” key on the WE-6 keypad. Refer to *Figure 11*. The display will show a temperature.

NOTE: Make sure that the external meter and the WE-6 are both reading °F or °C. The WE-6 may be prompted to display either °C or °F.

- h. While pressing the “Display Temperature” key, use a screwdriver to turn the temperature calibration screw until the WE-6 displays the same temperature as the external temperature meter.

NOTE: Turning the screw clockwise increases the displayed WE-6 temperature. Turning the screw counterclockwise decreases the displayed WE-6 temperature.

- i. When the temperatures match, calibration is completed. Close the control compartment and remove the external temperature sensor.
- j. The temperature probe leads and the temperature circuit wires in the control module must form twisted pairs to minimize interference from the A.C. drive during motor acceleration and deceleration. Twist the wire pairs together if this has not been done.
- k. Reinstall the computer board cover (refer to *Step c*) and the module top cover (refer to *Step b*).

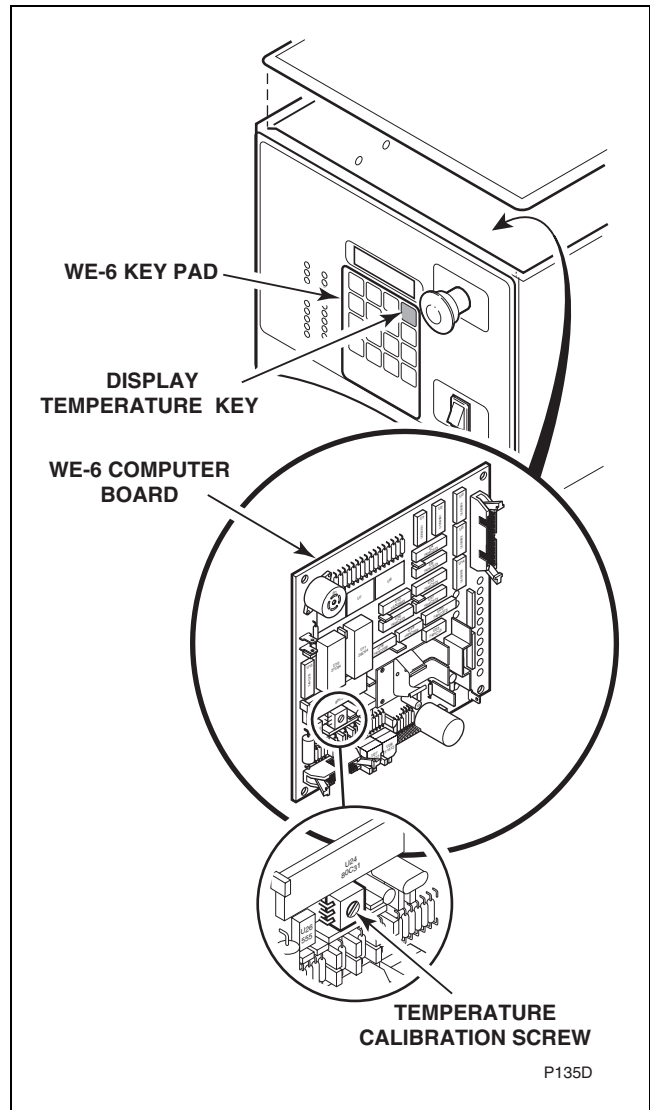

Figure 11
Temperature Calibration



WARNING

To reduce the risk of electrical shock, fire, explosion, serious injury or death:

- Disconnect electrical power to the washer-extractor before servicing it.
- Close the gas shut-off valve to the washer-extractor (when applicable) before servicing it.
- Never start the washer-extractor with any guards/panels removed.
- Whenever ground wires are removed during servicing, these ground wires must be reconnected to ensure that the washer-extractor is properly grounded.

W461R1

31. AC DRIVE REMOVAL AND INSTALLATION

The AC drive contains no user serviceable components. An optional parameter unit is available as a troubleshooting aid and to program factory authorized changes into the drive control.

IMPORTANT: Never change the preset parameters without consulting your distributor. Serious permanent damage could result to the AC drive and/or drive motor.

Removal and Installation

- a. Turn off power to the machine.
- b. Remove the two screws at the top rear edge of the module top cover and slide the cover back slightly until it can be removed. Remove the top cover.
- c. Loosen the screw that attaches the AC drive partition to the control module. Remove the AC drive partition. Refer to *Figure 12*.
- d. Mark the control signal wires (the wires going into the right side [facing the front of the machine] of the AC drive). Loosen the screws that connect the control signal wires to the AC drive. Remove the control signal wires from the AC drive. Refer to *Figure 12*.
- e. Mark the power wires and the ground wire (the wires going into the left side [facing the front of the machine] of the AC drive). Loosen the screws that connect the power wires and the ground wire to the AC drive. Remove the power wires and the ground wire from the AC drive. Refer to *Figure 12*.
- f. Remove the two screws on the left side of the drive (facing the front of the machine) that attach the AC drive to the control module.
- g. Loosen the two screws on the right side of the drive (facing the front of the machine) that attach the AC drive to the control module.
- h. Remove the AC drive.
- i. Installation is the reverse of removal.

NOTE: It is recommended that the wiring be reinstalled into the AC drive before the AC drive is reinstalled into the control module.

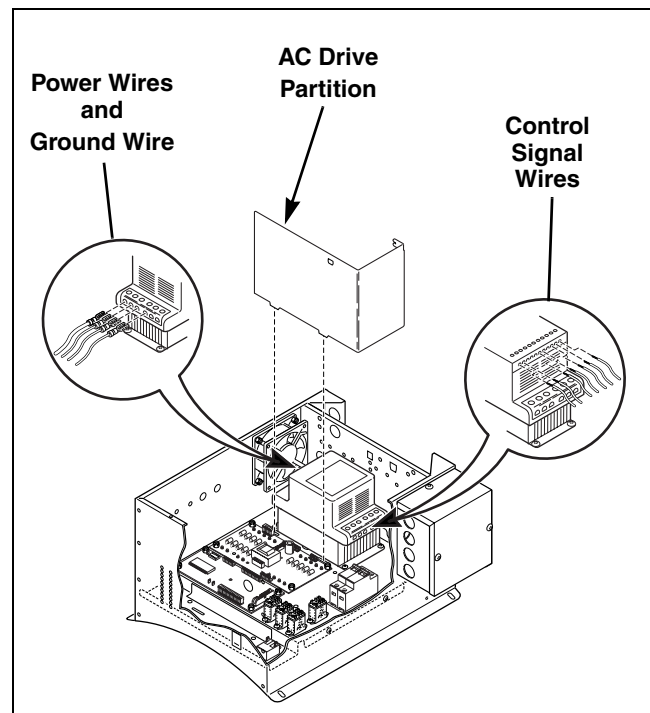

Figure 12



WARNING

To reduce the risk of electrical shock, fire, explosion, serious injury or death:

- Disconnect electrical power to the washer-extractor before servicing it.
- Close the gas shut-off valve to the washer-extractor (when applicable) before servicing it.
- Never start the washer-extractor with any guards/panels removed.
- Whenever ground wires are removed during servicing, these ground wires must be reconnected to ensure that the washer-extractor is properly grounded.

W461R1

32. DRIVE MOTOR

All motors for UWPV model machines are dual-voltage.

When using the 200 Volt AC drive, connect the motor for low voltage. When using the 400 Volt AC drive, connect motor for high voltage. Refer to *Figure 13*.

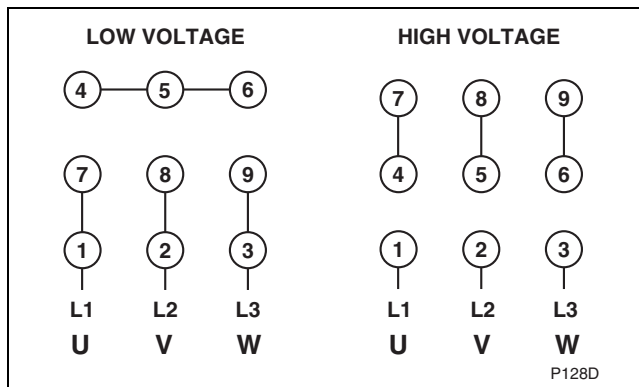

Figure 13

To change the direction of the motor rotation, reverse any two leads between the AC drive and the motor.

Service Tips

- If the motor makes a high-pitched sound, check the voltage. The rotor could also be out of alignment with the stator.
- If a motor has a reduced torque, check that the current draw in each leg is the same. If it varies more than 15%, either the motor winding or the power to the machine is faulty.
- If the motor does not receive power, check the AC drive power.
- If shorted or open windings are suspected, check them with an ohmmeter. All three legs must register the same amount of resistance (ohms).

Removal and Installation

Removal

- Turn off power to the machine.
- Remove the screws attaching the cage wrap and the back panel to the machine. Remove the cage wrap and the back panel. Refer to *Figure 14*.

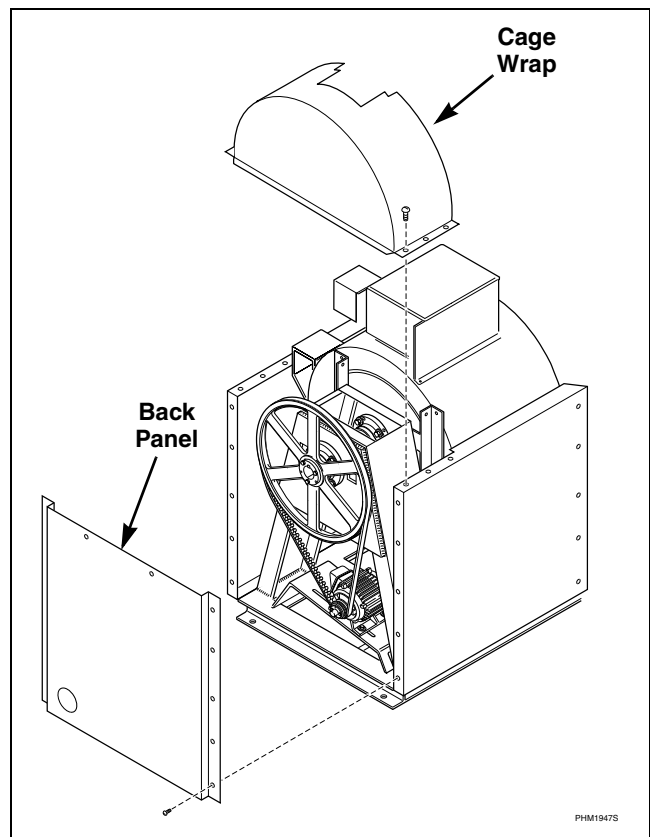

Figure 14

- Loosen the four bolts attaching the motor to the frame to relieve the belt pressure. Remove the belt. Refer to *Figure 15*.
- Remove the motor junction box cover. Refer to *Figure 15*.
- Mark and remove the three power wires and the ground wire.
- Remove the bolts attaching the motor to the frame. Remove the motor.



WARNING

To reduce the risk of electrical shock, fire, explosion, serious injury or death:

- Disconnect electrical power to the washer-extractor before servicing it.
- Close the gas shut-off valve to the washer-extractor (when applicable) before servicing it.
- Never start the washer-extractor with any guards/panels removed.
- Whenever ground wires are removed during servicing, these ground wires must be reconnected to ensure that the washer-extractor is properly grounded.

W461R1

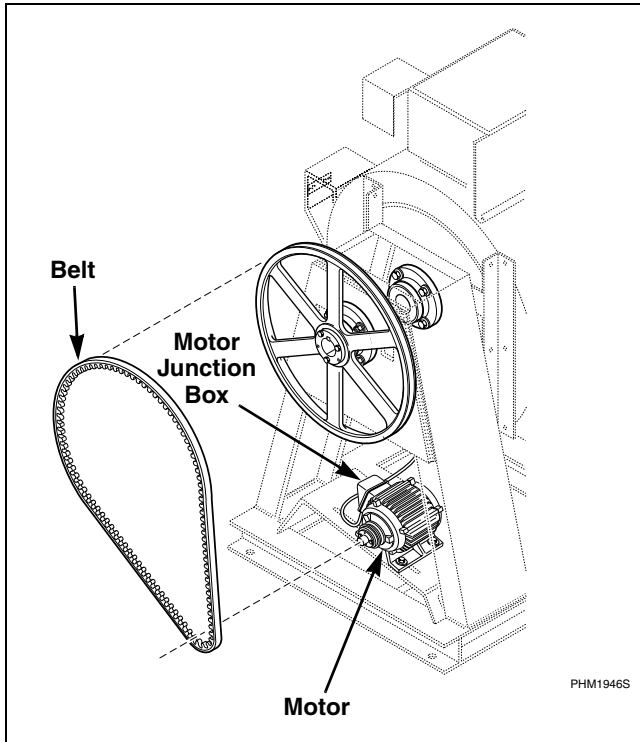

Figure 15

Installation

- a. Re-strip the power wires and the ground wire.
- b. Reconnect the power wires and the ground wire.
- c. Install the replacement motor with the four bolts that were removed from the previous motor.

NOTE: Do not completely tighten the bolts. The motor will need to be adjustable until the belt is re-tensioned.

- d. Reinstall the belt.
- e. Reposition the motor until the belt reaches the same tension as before the old motor was removed. Completely tighten the motor bolts.
- f. Reinstall the cage wrap and back panel.

33. DRIVE BELT

If the drive belt is generating noise or if the AC drive is generating faults because of excessive hertz fluctuations, first inspect the belt for wear. If the belt has uneven wear or frayed edges, replace it. Refer to the *Belt Replacement* section, below. If the drive belt isn't noticeably worn, check the belt's tension and deflection. Refer to the *Checking Belt Tension and Deflection* section, below.

Belt Replacement:

- a. Turn off power to the machine.
- b. Remove the screws attaching the cage wrap and back panels to the machine. Remove the cage wrap and back panel. Refer to *Figure 16*.

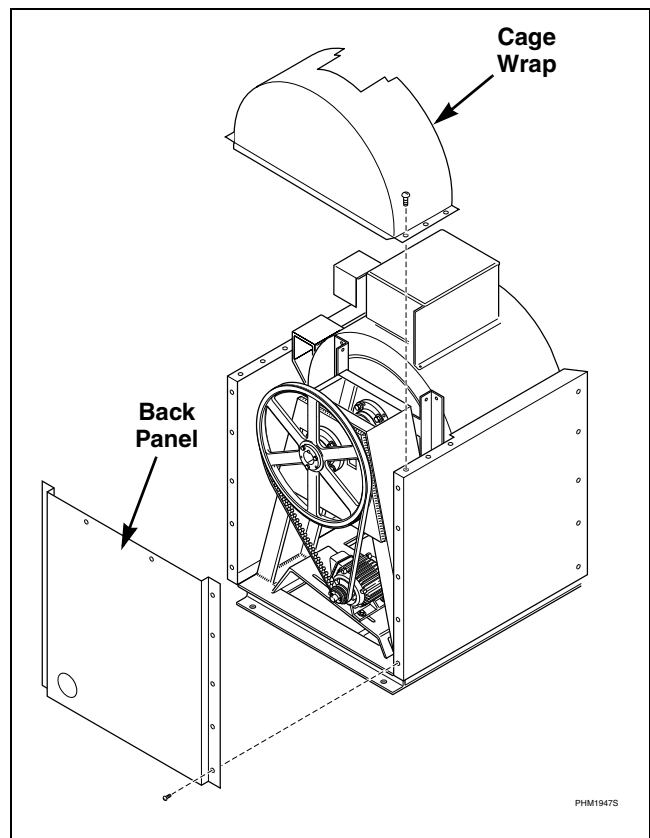

Figure 16



WARNING

To reduce the risk of electrical shock, fire, explosion, serious injury or death:

- Disconnect electrical power to the washer-extractor before servicing it.
- Close the gas shut-off valve to the washer-extractor (when applicable) before servicing it.
- Never start the washer-extractor with any guards/panels removed.
- Whenever ground wires are removed during servicing, these ground wires must be reconnected to ensure that the washer-extractor is properly grounded.

W461R1

- c. Loosen the motor mounting bolts and slide the motor along the motor plate to relieve the tension on the drive belt. Refer to *Figure 17*.

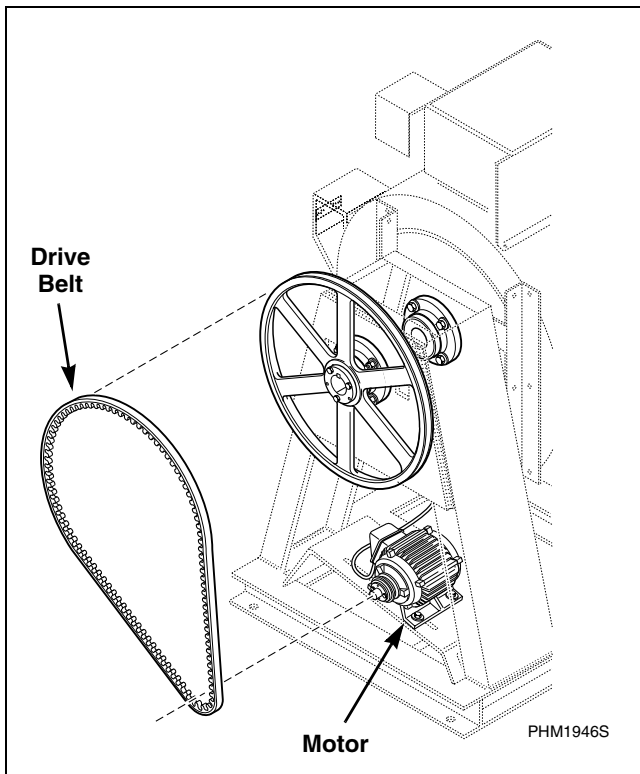

Figure 17

NOTE: Never install a drive belt by rolling it onto the pulleys. Rolling the belt onto the pulleys can damage the drive belt.

- d. Remove the drive belt from the pulleys.
- e. Install the new drive belt onto the pulleys.
- f. Re-tension the belt. Refer to *Checking Belt Tension and Deflection* section, below.
- g. Reinstall any panels that were removed in Step b.

Checking Belt Tension and Deflection:

- a. Turn off power to the machine.
- b. Remove the screws attaching the cage wrap and back panels to the machine. Remove the cage wrap and back panel. Refer to *Figure 16*.

- c. **Check drive belt tension.**

- (1) Using a tension gauge, check the drive belt tension. Belt tension should be between 70 and 90 pounds (± 5 pounds). Set the initial belt tension toward the high end of the range.
- (2) To adjust the drive belt tension, loosen the motor mounting bolts and slide the motor plate. Refer to *Figure 17*.

- d. **Check the belt deflection.**

- (1) Belt deflection measurements should be taken as close to the center of the belt span as possible. Refer to *Figure 18*.

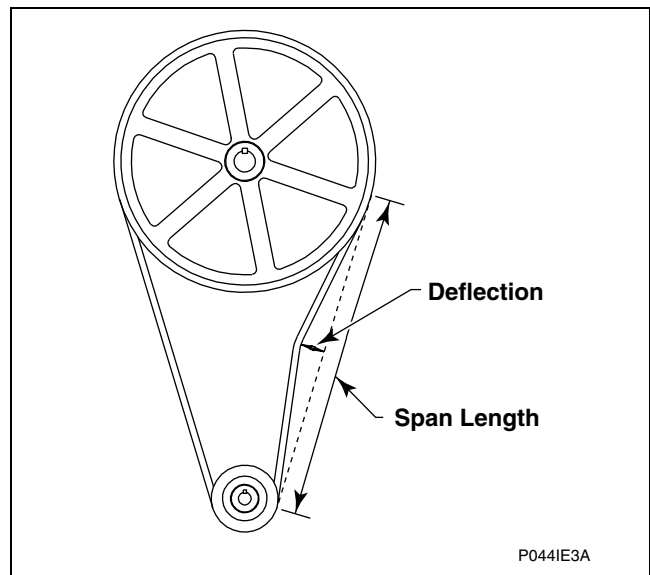

Figure 18

- (2) For every inch of span length, the drive belt should deflect 1/64 inch (.4 mm). For example, a belt with a span length of 50 inches should deflect 50/64 inch (19.84 mm).
 - (3) An initial (run-in) force of 5.25 pounds should be used to set the belt tension. An operating (normal) force of 3.5 pounds should be used after the washer-extractor has been operated for a few hours.
- e. Reinstall any panels that were removed in Step b.



WARNING

To reduce the risk of electrical shock, fire, explosion, serious injury or death:

- Disconnect electrical power to the washer-extractor before servicing it.
- Close the gas shut-off valve to the washer-extractor (when applicable) before servicing it.
- Never start the washer-extractor with any guards/panels removed.
- Whenever ground wires are removed during servicing, these ground wires must be reconnected to ensure that the washer-extractor is properly grounded.

W461R1

34. WATER LEVEL PRESSURE SWITCH

The pressure switch is set for predetermined water levels at the factory and adjustment is not recommended. The switches furnish inputs to the microcomputer that engage the water inlet valves until the programmed level (low, medium or high) is reached.

The pressure switch is connected to a rubber air trap that is attached to the shell sump. This air trap acts as an air reservoir so that water does not rise into the tube that connects the switch to the air trap. A pressure differential is created in the air trap as the machine fills with water. This results in a deflection of the pressure switch diaphragm.

The pressure switch has pre-set trip points and reset points. The low level reset point acts as a safety for spin. The spin contactor cannot energize until the low level reset point is reached. This prevents the machine from going into spin (extract) with water in the machine.

Service Tips

- a. If the pressure switch does not turn off a water fill (low, medium and high), check the air trap and tubing for blockages or leaks. The system must be air tight. Detergent residue may cause blockages.
- b. If the machine does not fill, check for continuity at the pressure switch.
- c. Connector J11-1 plugs onto the water level switch and the wires connect to the AC drive interface board. Refer to the wiring schematic supplied with machine for details.

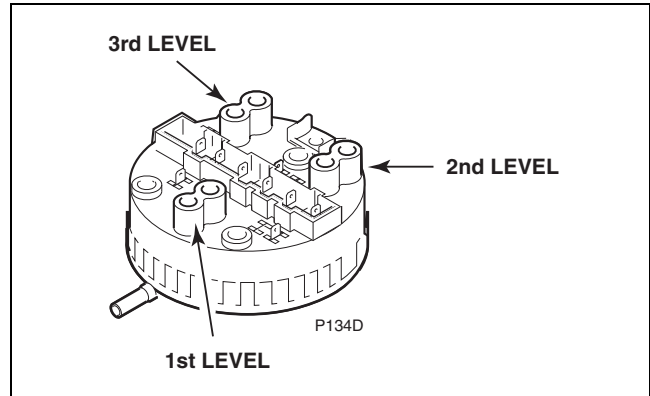

Figure 19
Level Switch

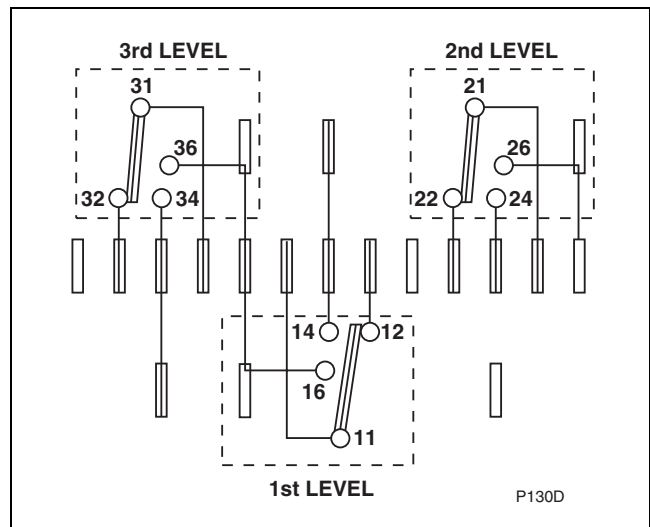

Figure 20
Water Level Pressure Switch Terminals



WARNING

To reduce the risk of electrical shock, fire, explosion, serious injury or death:

- Disconnect electrical power to the washer-extractor before servicing it.
- Close the gas shut-off valve to the washer-extractor (when applicable) before servicing it.
- Never start the washer-extractor with any guards/panels removed.
- Whenever ground wires are removed during servicing, these ground wires must be reconnected to ensure that the washer-extractor is properly grounded.

W461R1

Removal and Installation

- Turn off power to the machine.
- Remove the two screws at the top rear edge of the module top cover and slide the cover back slightly until it can be removed. Remove the module top cover.
- Remove the header. Refer to *Figure 21*.
- Depress the retaining clip on the back of the pressure switch. Remove the pressure switch. Refer to *Figure 21*.
- Remove the tubing from the pressure switch. Refer to *Figure 21*.
- Installation is the reverse of removal.

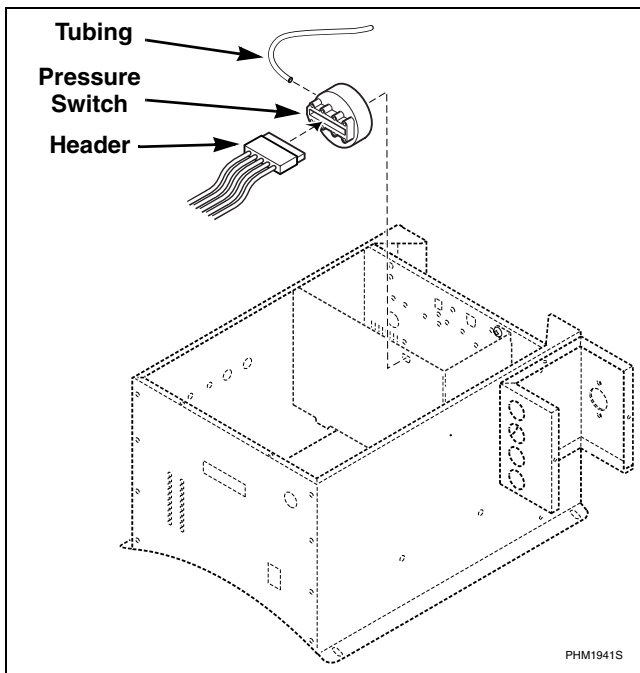

Figure 21

35. WATER VALVE

If water continues to come into the machine when no power is applied to the machine, there is a mechanical problem with the valve. The valve may also be worn or dirty.

Check the valve's filter screen and flow restrictor and clean them as needed. Inspect the valve for cracks. If the valve is cracked, replace it.

If the valve isn't cracked and the filter screen and flow restrictor are clean, see the machine's parts manual for the valve repair kit part number. If the valve repair kit doesn't stop water from coming into the machine without power being applied, replace the valve.

Refer to *Figure 22* for an exploded view of the valve.

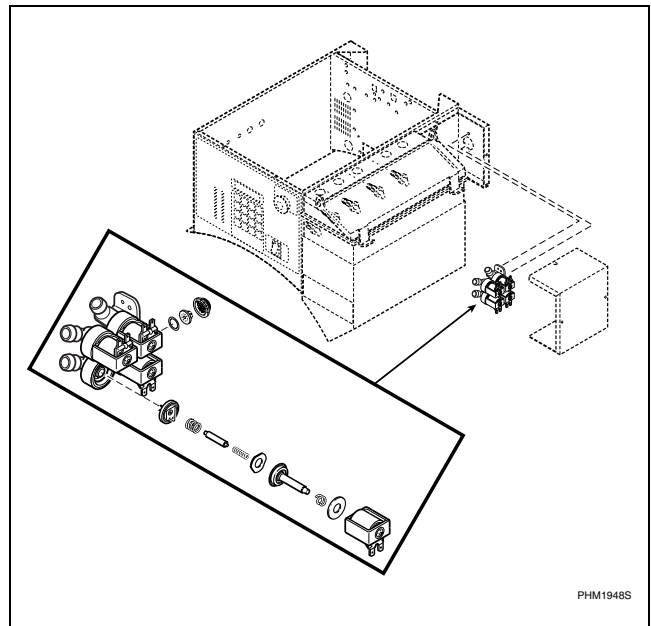

Figure 22



WARNING

To reduce the risk of electrical shock, fire, explosion, serious injury or death:

- Disconnect electrical power to the washer-extractor before servicing it.
- Close the gas shut-off valve to the washer-extractor (when applicable) before servicing it.
- Never start the washer-extractor with any guards/panels removed.
- Whenever ground wires are removed during servicing, these ground wires must be reconnected to ensure that the washer-extractor is properly grounded.

W461R1

36. DRAIN VALVE

If the washer-extractor doesn't drain within 30 seconds, perform the following check. Refer to *Figure 23*.

- a. Turn off power to the machine.
- b. Remove any panels necessary to access the drain valve and drain plumbing.
- c. Check for a clog in the drain line.
- d. Verify that the drain valve is opening.
 - (1) The drain valve is normally open (i.e., it requires voltage to close).
 - (2) When power is removed from the machine, the drain valve should open.
- e. If the drain is not opening, check for the following:
 - (1) Check the motor winding for continuity, a short circuit or an abnormal drop in voltage. Replace the drain valve motor as needed (consult the machine's parts manual for drain valve motor part numbers).
 - (2) Check that the shaft and rotor of the drain motor turns freely.
 - (3) Check that the internal drain valve is closing and does not bind. A clog within the drain valve may be preventing the drain valve from closing. Replace the drain valve as needed (consult the machine's parts manual for drain valve part numbers).
- f. Re-install any panels removed in Step 2.

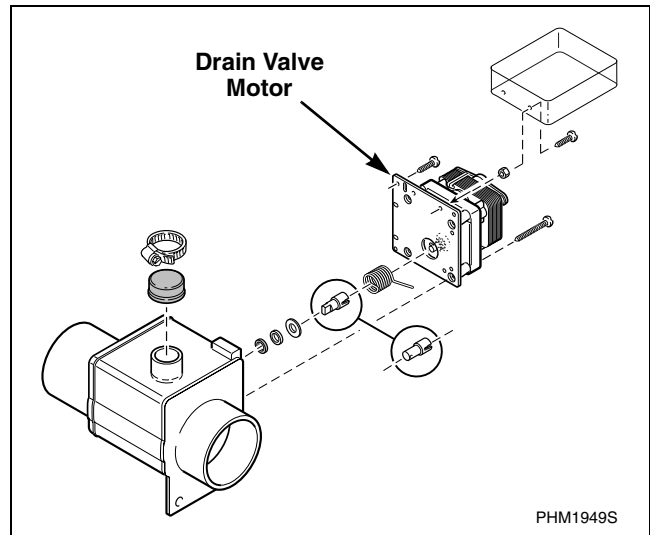

Figure 23

37. FLANGE RELAY REMOVAL AND INSTALLATION

- a. Turn off power to the machine.
- b. Remove the two screws at the top rear edge of the module top cover and slide the cover back slightly until it can be removed. Remove the module top cover.
- c. Remove the quick disconnect from the top of the flange relay. Refer to *Figure 24*. All wires remain in the same spot.
- d. Remove one of the screws that attaches the flange relay to the control module. Refer to *Figure 24*.

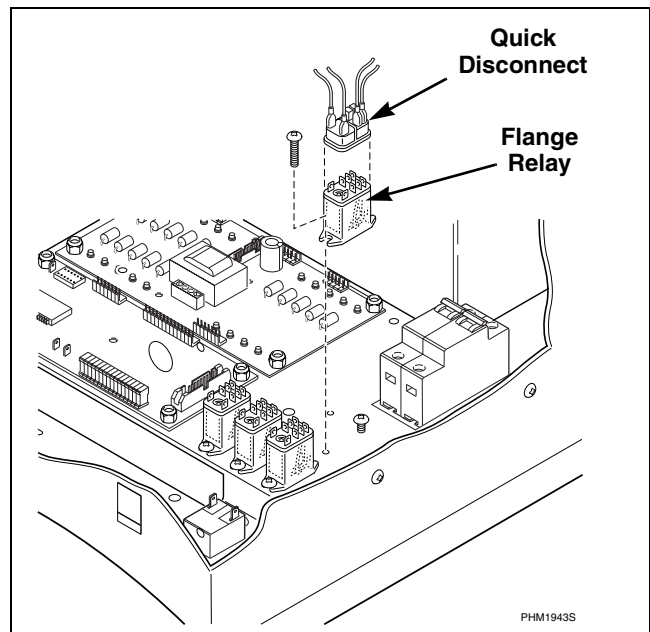

Figure 24

- e. Loosen the other screw that attaches the flange relay to the control module.
- f. Remove the flange relay. Refer to *Figure 24*.
- g. Installation is the reverse of removal.



WARNING

To reduce the risk of electrical shock, fire, explosion, serious injury or death:

- Disconnect electrical power to the washer-extractor before servicing it.
- Close the gas shut-off valve to the washer-extractor (when applicable) before servicing it.
- Never start the washer-extractor with any guards/panels removed.
- Whenever ground wires are removed during servicing, these ground wires must be reconnected to ensure that the washer-extractor is properly grounded.

W461R1

38. VACUUM BREAKER

If the machine's vacuum breaker is leaking, verify that water pressure to the machine is between 30 and 85 psi. If the water pressure is between 30 and 85 psi, repair the vacuum breaker using a vacuum breaker repair kit (refer to the machine's parts manual for vacuum breaker repair kit part numbers).

39. DOOR GASKET REMOVAL AND INSTALLATION

Turn off power to the machine.

Removal

Depress the door gasket and roll it away from the door. Refer to *Figure 25*.

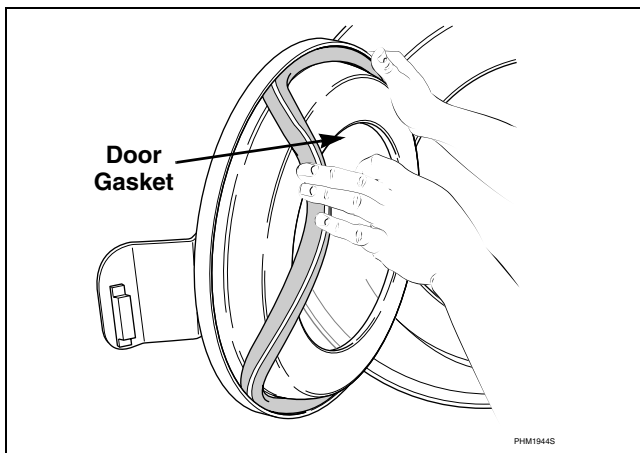

Figure 25

Installation

Depress the door gasket and roll it toward the door in a star-shaped pattern. Refer to *Figure 26*.

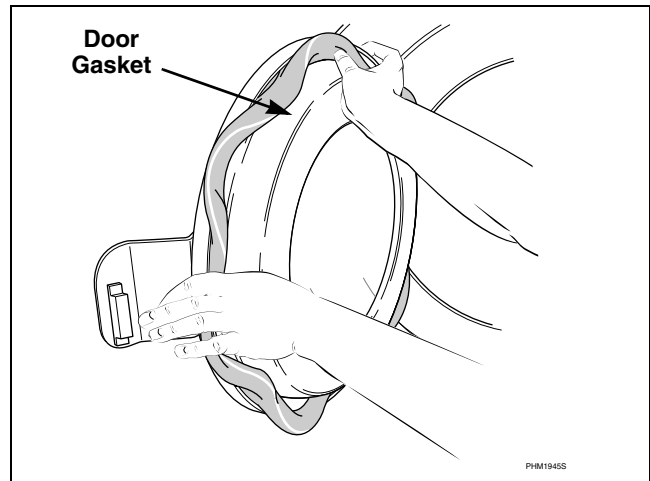

Figure 26



WARNING

To reduce the risk of electrical shock, fire, explosion, serious injury or death:

- Disconnect electrical power to the washer-extractor before servicing it.
- Close the gas shut-off valve to the washer-extractor (when applicable) before servicing it.
- Never start the washer-extractor with any guards/panels removed.
- Whenever ground wires are removed during servicing, these ground wires must be reconnected to ensure that the washer-extractor is properly grounded.

W461R1

40. BEARINGS AND CARTRIDGE SEAL REPLACEMENT

- a. Remove the three screws and the door lock cover from the front of machine. Refer to *Figure 27*.
- b. Disconnect the spray rinse hose from the spray tube assembly. Refer to *Figure 27*.

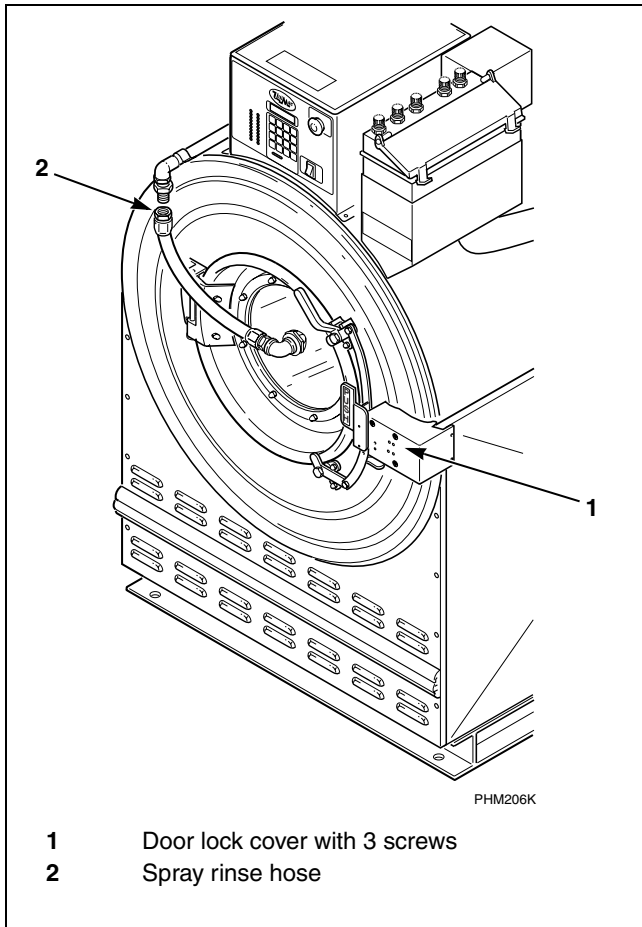

Figure 27

- c. Remove the front, back, top and side panels. Refer to *Figure 28*.

- d. Using a permanent marker, make a mark on the shell front and shell so that the shell front will be reinstalled in the correct position.

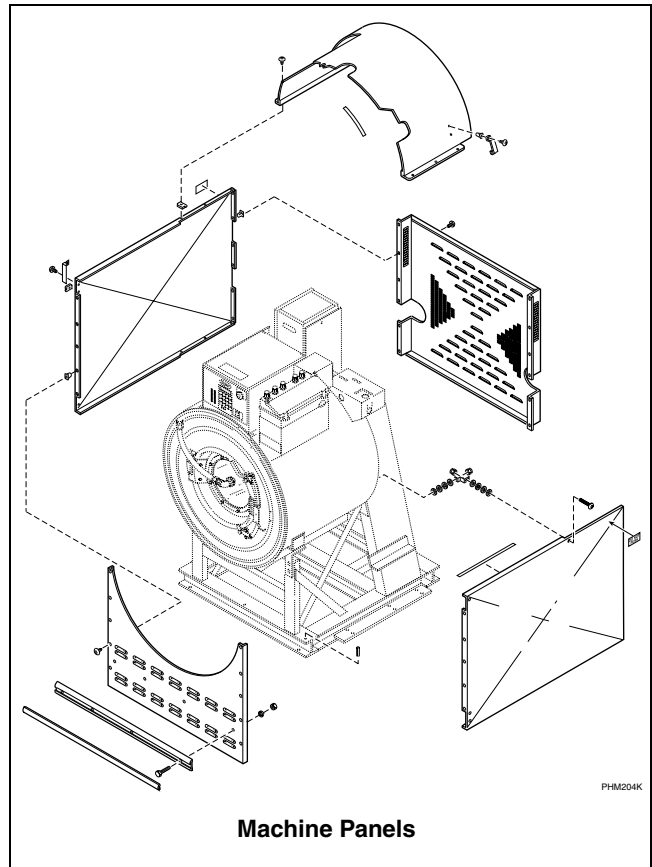
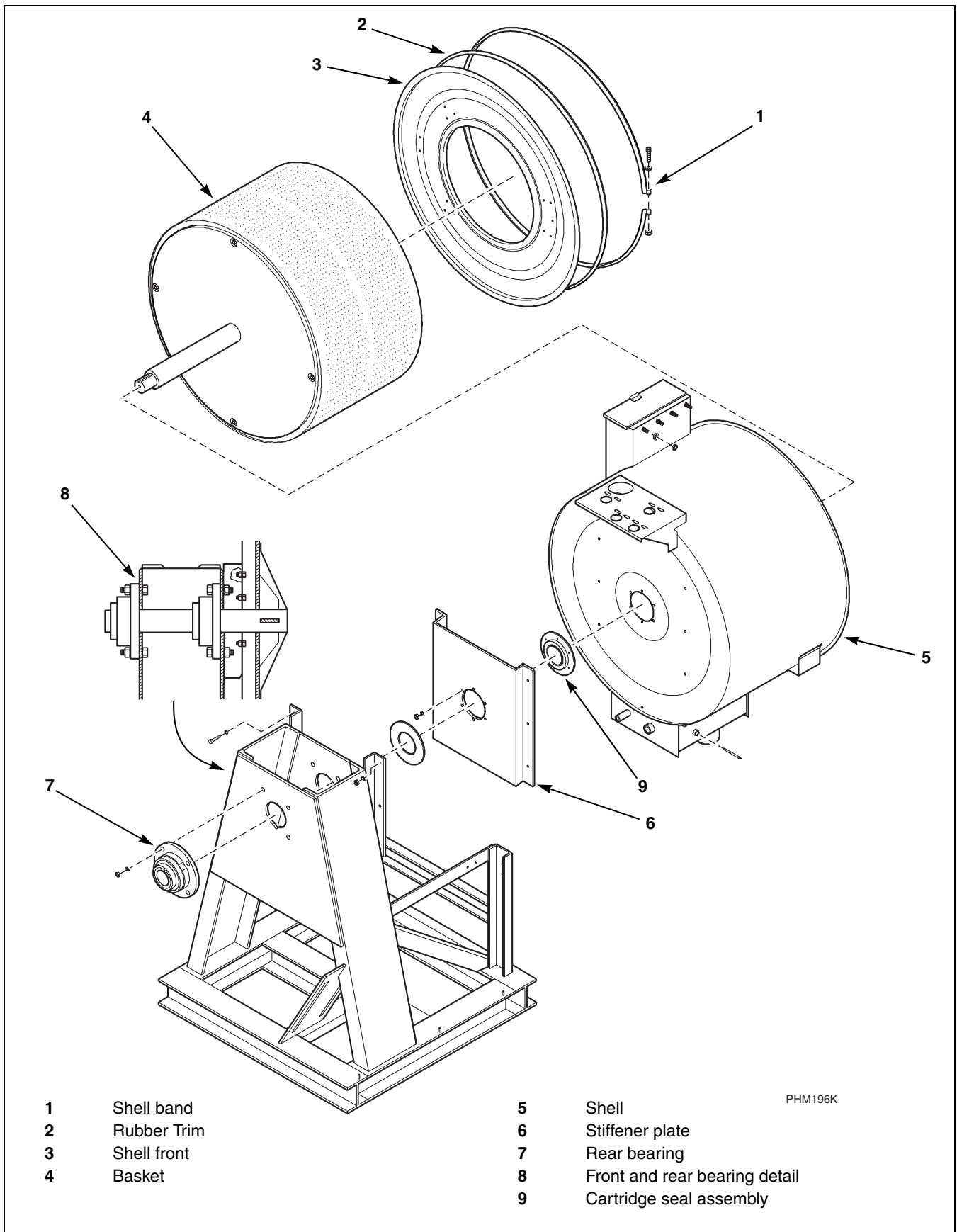

Figure 28

- e. Remove the nut, bolt and shell band from around the door. Refer to *Figures 29* and *30*.
- f. Remove the rubber trim from around the door/shell.
- g. Pull the shell front off of the machine.



- 1 Shell band
- 2 Rubber Trim
- 3 Shell front
- 4 Basket

- 5 Shell
- 6 Stiffener plate
- 7 Rear bearing
- 8 Front and rear bearing detail
- 9 Cartridge seal assembly

PHM196K

Figure 29
UW35

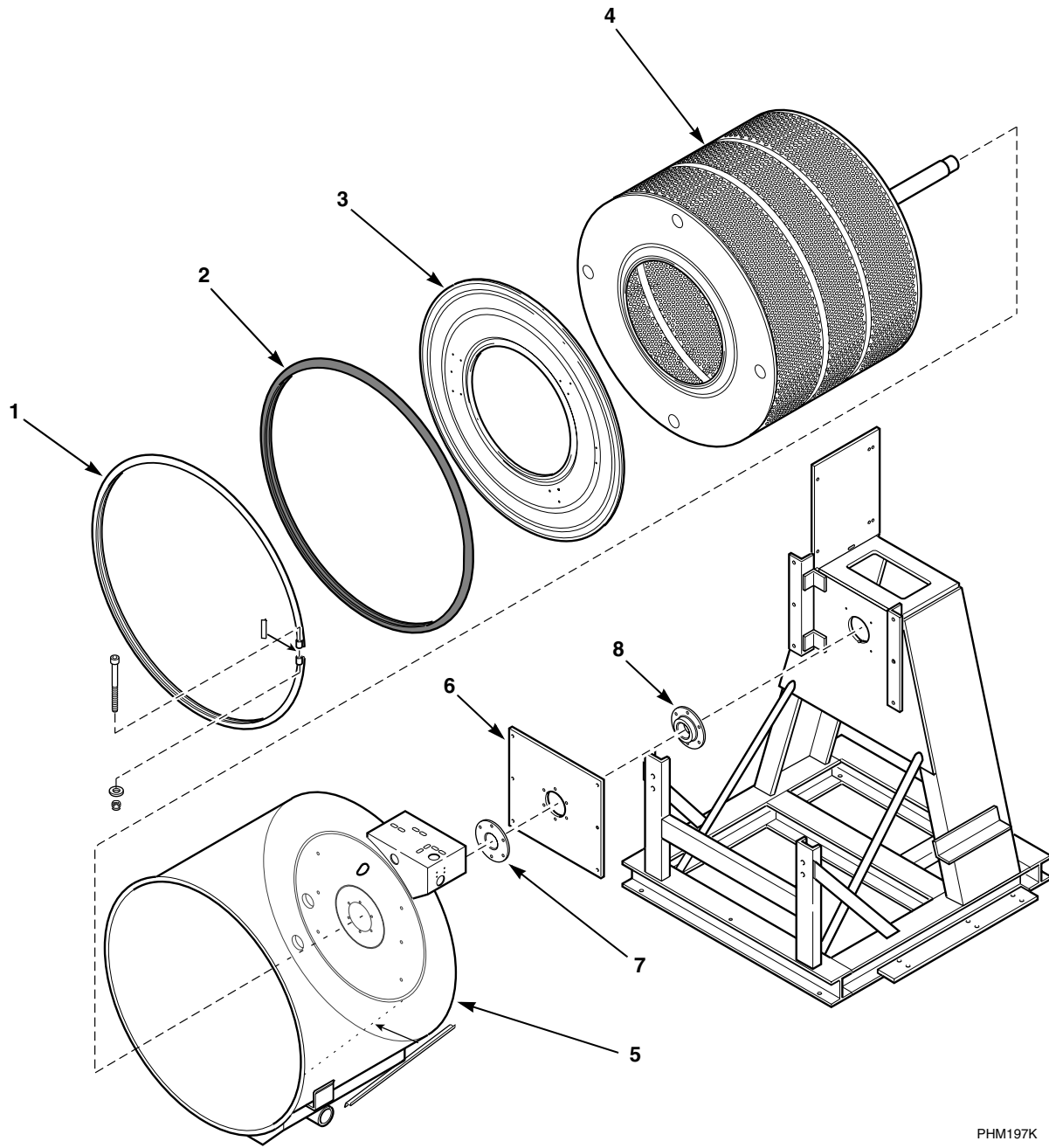

PHM197K

- 1 Shell band
- 2 Rubber Trim
- 3 Shell front
- 4 Basket

- 5 Shell
- 6 Stiffener plate
- 7 Gasket
- 8 Cartridge seal assembly

Figure 30
UW60, UW80, UW100 and UW125



WARNING

To reduce the risk of electrical shock, fire, explosion, serious injury or death:

- Disconnect electrical power to the washer-extractor before servicing it.
- Close the gas shut-off valve to the washer-extractor (when applicable) before servicing it.
- Never start the washer-extractor with any guards/panels removed.
- Whenever ground wires are removed during servicing, these ground wires must be reconnected to ensure that the washer-extractor is properly grounded.

W461R1

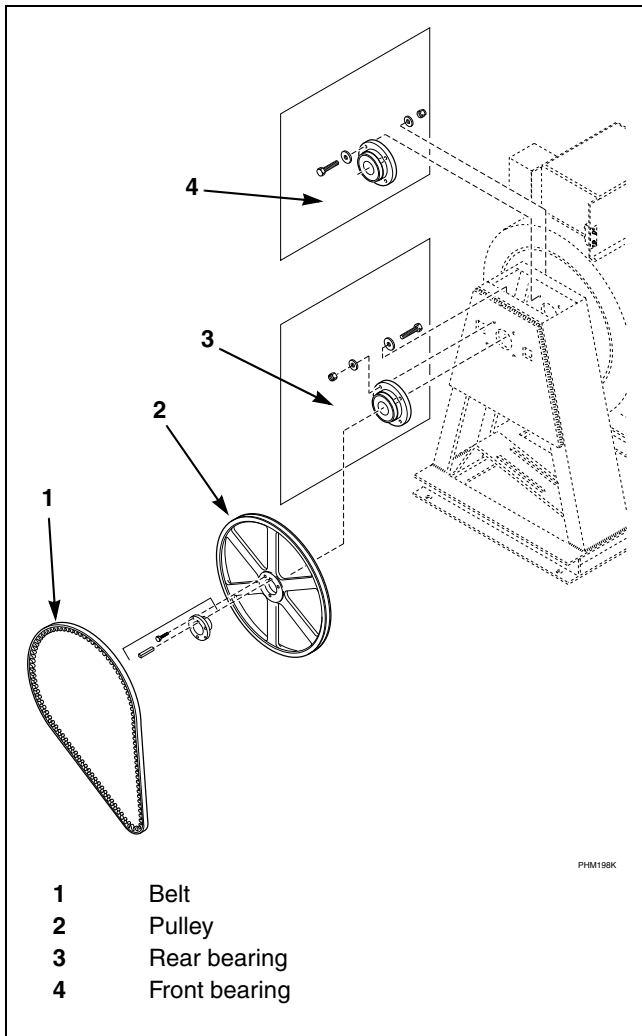

Figure 31

- h. Remove the belt from the pulley. Remove the bolts from the pulley and place them in the hub bushing. Tighten those bolts equally until the bolts force the bushing from the hub. Remove the pulley. Refer to *Figure 31*.
- i. If the machine's bearings are similar to *Figure 32* (old style bearing), loosen the lock collar set screws until both of the collars can be slid off of their bearing inner races. Grasp the inner race of the bearing with a pipe wrench and rotate the shaft by turning the basket. If this

fails to free the bearing, Alliance Laundry has a tool to assist in loosening and removing the bearing.

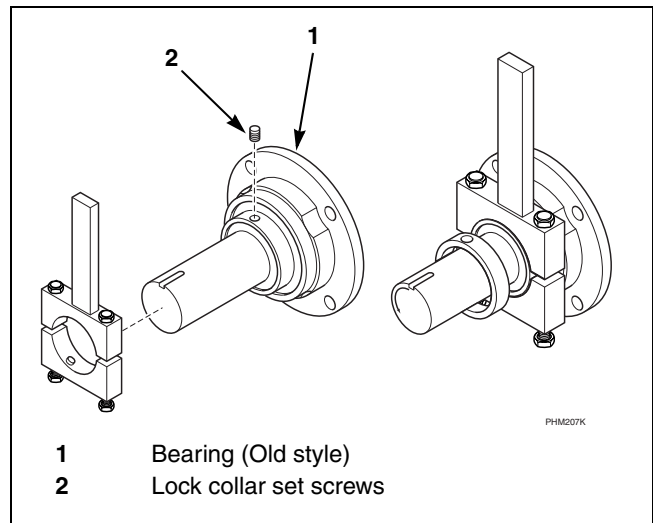

Figure 32

- j. If the machine's bearings are similar to *Figure 33* (new style SKF bearing), loosen the front and the rear bearing's set screws (until 3 threads are showing) using a short 3mm Allen wrench.

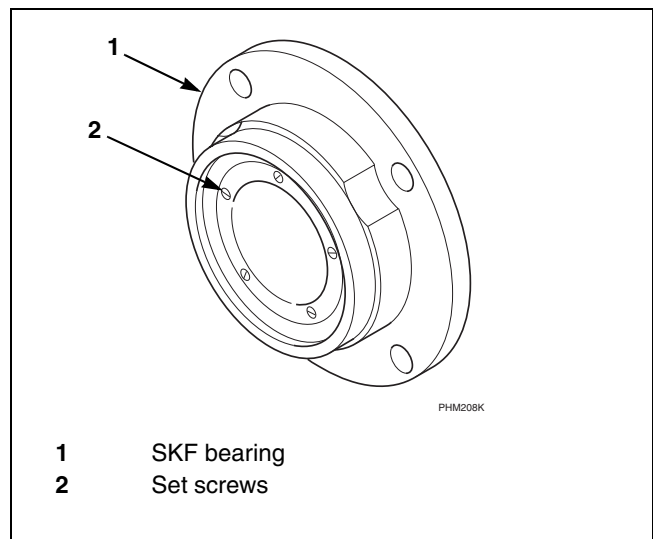

Figure 33



WARNING

To reduce the risk of electrical shock, fire, explosion, serious injury or death:

- **Disconnect electrical power to the washer-extractor before servicing it.**
- **Close the gas shut-off valve to the washer-extractor (when applicable) before servicing it.**
- **Never start the washer-extractor with any guards/panels removed.**
- **Whenever ground wires are removed during servicing, these ground wires must be reconnected to ensure that the washer-extractor is properly grounded.**

W461R1

- k. Mark the shaft where it contacts the bearing sleeve. This mark will be used to determine if the procedure described below unseats the bearing.
- l. Drive the shaft through the bearings by impacting the end of the shaft with a rubber hammer. If this force is insufficient, a sledgehammer can be used if care is taken to protect the end of the shaft. If the force from a rubber hammer or sledgehammer is insufficient, use a puller to drive the shaft through the bearings. A distinctive "pop" will be heard once the bearings become unseated from the shaft.
- m. Verify that the shaft is loose from the bearings by moving the basket forward. The shaft should move freely though the bearing.
- n. Remove the screws and the brass collar from the basket.
- o. Remove the basket from the machine.
- p. Remove the nylon retainer and carbon seal from the shell.

NOTE: If necessary, pull the shell back away from the frame by removing the 6 nuts holding the stiffener plate and shell to the frame.

- q. Clean the shell (inside and out), removing all dirt, oil and dried silicone.

Mounting Instructions

- a. Using a micrometer, verify that shaft diameter is within the +0.000/-0.004 inches in tolerance. Refer to *Table 1*. Measure the location on the shaft where the bearings will be mounted. Check the end of the shaft for any burrs or lips created from impact damage. If the shaft is not within the listed tolerance, it should be replaced.

Model	Shaft Diameter	+/- Tolerance (inches)
35, 60	2.4375	2.4375-2.4335
80, 100	2.9375	2.9357-2.9335
125	3.4375	3.4375-3.4335

Table 1

- b. Clean and lubricate the entire shaft and apply oil between the bearing inner race and the shaft.
- c. Remove the plastic inserts from the bearing(s).
- d. Slide the bearing(s) over the shaft to verify that the shaft is the correct size and that the bearings have not been damaged in shipment.
- e. Torque the front bearing to the frame. Refer to *Table 2* for specifications.

Model UW	Bearing	Bolt size	Torque (ft.-lbs. (N-M))
35	Front	5/8-18 x 2-3/4	197 (267)
35	Rear	9/16-18 x 2-1/2	140 (190)
60	Front	5/8-18 x 2-3/4	197 (267)
60	Rear	9/16-18 x 2-1/2	140 (190)
80,100	All	3/4-16 x 2-3/4	285 (386)
125	All	7/8-14 x 3	500 (678)

Table 2

- f. Bolt the rear bearing to the frame. Leave the bolts loose enough so that the rear bearing can be moved against the frame.

NOTE: Do not put silicone in the seal area.

- g. On all models except for UW35, install a gasket between the stiffener plate and the shell back and align the bolts. Refer to *Figure 30*.

NOTE: File the shell opening if the new cartridge does not fit without interference.

NOTE: Remove any burrs from the key that is located on the end of the basket shaft.

- h. Install a new cartridge seal onto the machine (without using RTV) with the gasket against shell back, leaving the bolts loose, refer to *Figure 30*.

NOTE: Make sure that the shell is tightened to the frame and the stiffener plate.

- i. Clean the alignment shaft and apply a light coat of oil to it with a clean cloth to assist with the insertion of it through the bearings.



WARNING

To reduce the risk of electrical shock, fire, explosion, serious injury or death:

- Disconnect electrical power to the washer-extractor before servicing it.
- Close the gas shut-off valve to the washer-extractor (when applicable) before servicing it.
- Never start the washer-extractor with any guards/panels removed.
- Whenever ground wires are removed during servicing, these ground wires must be reconnected to ensure that the washer-extractor is properly grounded.

W461R1

Do not hit the inner sleeve of the rear bearing. Insert the alignment shaft from the rear of the machine through the back bearing, mating it end first.

Do not hit the inner sleeve of the front bearing. Slowly advance the shaft through the front bearing.

- j. Use the alignment shaft to align the cartridge assembly with the two bearings.
- k. Use a star pattern to tighten the cartridge to the shell back. The bolts should stick through the back of the stiffener plate on UW35 models.
- l. On UW35 models, tighten the nuts to clamp the stiffener plate to the back of the nylon retainer.

NOTE: A minimum of two people are required to complete the remaining steps.

- m. With the basket at the proper height to mate with the alignment shaft, advance the basket shaft and mate it with the alignment shaft. One person should be at the rear of the machine to hold pressure against the alignment shaft and another person should align the basket.
- n. Once the alignment shaft and the basket shaft are mated, hold pressure against the alignment shaft to ensure that the two shafts are joined. Guide the basket shaft through the two bearings.
- o. Once the basket shaft has cleared the rear bearing, remove the alignment shaft.

- p. Torque the rear bearing. Refer to *Table 2*.
- q. Set the basket front to the shell front gap. Refer to *Table 3*.

Model	Inches	+/- Tolerance
35	3/16	5/16-3/16
60	3/16	5/16-3/16
80,100	1/4	3/8-1/4
125	3/8	1/2-3/8

Table 3

NOTE: Failure to follow the following procedures will result in incorrectly installed bearings and premature bearing failure.

- r. **Snug the Rear Bearing:** Using a short 3mm Allen wrench, tighten the mounting side set screws on the rear bearing until only two threads on each screw are visible. Alternate in 1/2 turn increments according to the pattern shown in *Figure 34*. Ensure that the mounting collar still rotates freely.
- s. **Snug the Front Bearing:** Using a short 3mm Allen wrench, tighten the mounting side set screws on the front bearing until only two threads on each screw are visible. Alternate in 1/2 turn increments according to the pattern shown in *Figure 34*. Ensure that the mounting collar still rotates freely.

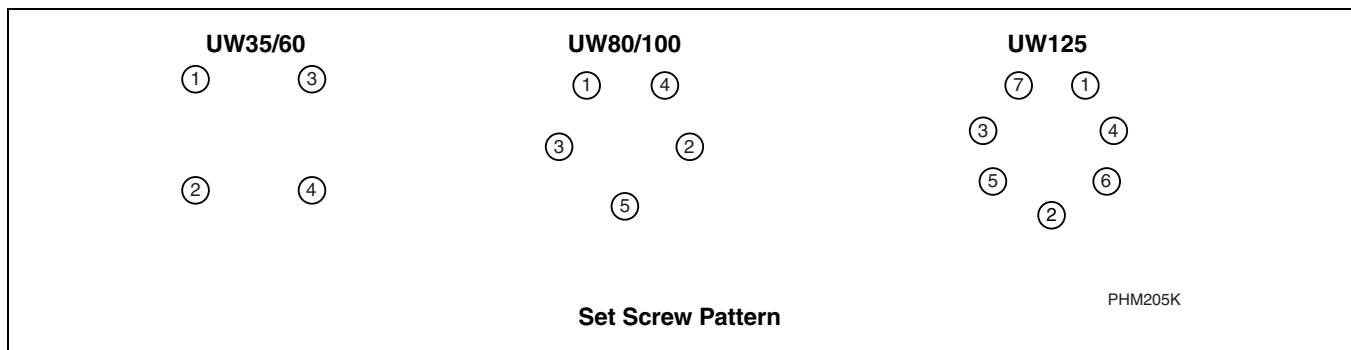

Figure 34



WARNING

To reduce the risk of electrical shock, fire, explosion, serious injury or death:

- Disconnect electrical power to the washer-extractor before servicing it.
- Close the gas shut-off valve to the washer-extractor (when applicable) before servicing it.
- Never start the washer-extractor with any guards/panels removed.
- Whenever ground wires are removed during servicing, these ground wires must be reconnected to ensure that the washer-extractor is properly grounded.

W461R1

- t. **Torque the Front Bearing:** Make sure that the short 3mm Allen wrench is secured in the head of the set screw. Alternately tighten the mounting set screws in 1/2 turn increments until they are tightened to 80in-lbs of torque. The Allen wrench is designed to flex approximately 3/4 inches when 80 in-lbs is achieved.
- u. **Torque the Rear Bearing:** Make sure that the short 3mm Allen wrench is secured in the head of the set screw. Alternately tighten the mounting set screws in 1/2 turn increments until they are tightened to 80in-lbs of torque. The Allen wrench is designed to flex approximately 3/4 inches when 80 in-lbs is achieved.
- v. Recheck each set screw and retighten them as needed. No threads should be visible.
- w. Check the up and down play of the basket. The bearings are not correctly mounted if play exists.
- x. Apply methoxy sealant at the split of the bearing sleeve.

NOTE: Make sure that the new cartridge seal has 0.125 inches of axial (spring pressure) movement in it.

- y. After the bearings are set, check to see if the metal ring on the seal is against the nylon retainer. If needed, slide the brass collar forward until the ring comes into contact with the nylon. This will set the correct seal spring compression. Refer to *Figure 35*.

- z. Tighten the brass collar to the shaft using the three set screws located in the brass collar.
- aa. Remove the retaining ring from the cartridge seal using a screwdriver. Refer to *Figure 35*.

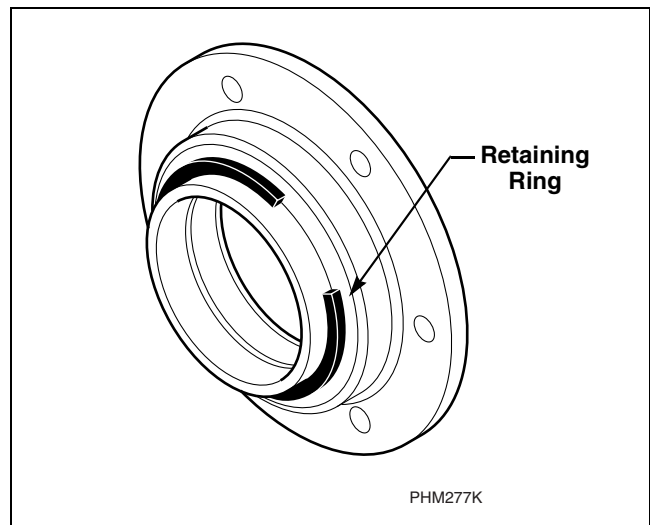

Figure 35

- ab. Reinstall the pulley and the belt.
- ac. Reinstall the door trim and shell band. Realign them using the marks made in the previous step.
- ad. Reinstall the door lock cover on the machine.
- ae. Reconnect the spray rinse hose to the spray tube assembly.
- af. Reinstall all of the panels.
- ag. Test the machine for leaks.



WARNING

To reduce the risk of electrical shock, fire, explosion, serious injury or death:

- Disconnect electrical power to the washer-extractor before servicing it.
- Close the gas shut-off valve to the washer-extractor (when applicable) before servicing it.
- Never start the washer-extractor with any guards/panels removed.
- Whenever ground wires are removed during servicing, these ground wires must be reconnected to ensure that the washer-extractor is properly grounded.

W461R1

41. BEARING ALIGNMENT

NOTE: Severe out-of-balance loads can cause misalignment of the flange-mounted bearings. Use the following procedure to align and torque the bearings.

- a. Disconnect the power to the machine.
- b. Tighten the rear bearing collar's set screws to hold the basket shaft in place. Do not torque them at this time.
- c. Loosen the front bearing collar's set screws.
- d. Connect power to the machine.
- e. Start and run the machine in "medium" spin for 30 seconds to allow the bearing race to align.
- f. Stop the machine and disconnect the power.
- g. Apply loctite to the set screw threads.
- h. Tighten the front bearing collar's set screws evenly by alternating between two of them until they are snug. Finish tightening them with a torque wrench until the correct torque is achieved.
- i. Loosen the rear bearing collar's set screws.
- j. Apply power to machine.
- k. Start and run the machine in "medium" spin for 30 seconds to allow the bearing race to align.
- l. Apply loctite to the set screw threads.
- m. Tighten the rear bearing collar's set screws evenly by alternating between two of them until they are snug. Finish tightening them with a torque wrench until the correct torque is achieved.

Bearing Troubleshooting Tips

- a. "Knocking" sound during operation:
 - (1) Ensure that the mounting set screws are adequately tightened and that the dismantling set screws are in their original position, protected by yellow plastic plugs.
 - (2) Ensure that the machine is secured to the floor according to the manufacturer's instructions.
 - (3) If there is noticeable up and down play with the basket, go to tip #3.
 - (4) If the noise persists, replace the bearing. For warranty purposes, the old bearing should be returned to the manufacturer for a complete analysis.
- b. Occasional slight noise during high speed spin:
 - (1) Pump a small amount of fresh grease into the bearing unit.
 - (2) Check for basket play when the machine is empty and not running. If there is basket play, proceed to tip #3.
- c. Basket play when the machine is empty and not running:
 - (1) Further tighten each mounting set screw to remove bearing clearance (up to 90 in-lbs is allowable).
 - (2) If the basket play persists, dismount and remount the bearings by following the steps outlined in the instructions (without unbolting the bearing housing from the steel frame).
 - (3) If the basket play persists, replace the bearing. For warranty purposes, the old bearing should be returned to the manufacturer for a complete analysis.

